

K'NEX
HyperSpace™
TRAINING TOWER



USA (GB) Set contains one (1) Battery PowerPack™. (Batteries not included.) *Install batteries before building models. Keep hands, face, hair, clothing and Power Cord away from all moving parts.*

F Ce jeu contient un (1) bloc d'alimentation sur piles PowerPack™. (Se procurer les piles séparément.) *Mettre les piles en place avant de construire les modèles. Tenez toute pièce mobile à l'écart des mains, du visage, des cheveux, des vêtements et du cordon d'alimentation.*

I Il set contiene un (1) PowerPack™ a batteria. (Batterie non incluse nella confezione.) *Installare le batterie prima di costruire i modelli. Tenere le mani, il viso, i capelli, gli indumenti e il cavo di alimentazione lontani dalle parti in movimento.*

D Satz enthält ein (1) batteriebetriebenes PowerPack™. (Batterien nicht eingeschlossen.) *Vor dem Bau der Modelle die Batterien installieren. Halten Sie Hände, Gesicht, Haar, Kleidung und Stromkabel von beweglichen Teilen fern.*

E El juego contiene un (1) baterías PowerPack™. (Las baterías no están incluidas.) *Coloca las baterías antes de armar los modelos. Mantener las manos, cara, pelo, ropa y cable de alimentación alejados de todas las piezas móviles.*

S Satsen innehåller ett (1) Battery PowerPack™. (Batterier medföljer ej.) *Installera batterierna innan du bygger modellerna. Håll händer, ansikte, hår och kläder samt nätsladden borta från alla rörliga delar.*

DK Sættet indeholder én (1) Battery PowerPack™. (Batterier er ikke inkluderet.) *Batterierne skal installeres inden modellerne bygges. Hold hænder, ansigt, hår, tøj og el-ledning væk fra alle bevægelige dele.*

N Dette settet består av én (1) Battery PowerPack™. (Batterier er ikke inkludert.) *Batteriene må installeres før modellene bygges. Hold hender, ansikt, hår, klær og strømføring unna alle bevegelige deler.*

SF Sarja sisältää yhden (1) PowerPack™. (Paristot eivät seuraa mukana.) *Asenna paristot ennen kuin rakennat malleja. Pidä kädet, kasvat, hiukset, vaatteet ja sähköjohto etäällä liikkuvista osista.*

NL Set bevat één (1) Batterij-PowerPack™. (Batterijen niet inbegrepen.) *Installeer de batterijen voordat je de modellen gaat bouwen. Hand, gezicht, haar, kleding en het netsnoer uit de buurt van alle bewegende delen houden.*

P O conjunto contém um (1) Battery PowerPack™ de pilhas. (Pilhas não incluídas.) *Instale as pilhas antes de montar o modelo. Mantenha as mãos, o cabelo, peças de vestuário e o cabo de alimentação afastados das peças em movimento.*

G Το σετ περιέχει ένα (1) Battery PowerPack™. (Οι μπαταρίες δεν περιλαμβάνονται.) *Τοποθετήστε τις μπαταρίες πριν κατασκευάσετε τα μοντέλα. Αποφεύγετε να βάζετε χέρια πρόσωπο, μαλλιά, ρούχα και καλώδιο τροφοδοσίας κοντά σε κινούμενα εξαρτήματα.*

TR Sette bir (1) PowerPack™ Pili vardır. (Piller dahil değildir.) *Pilleri modelleri monte etmeden takın. Ellerinizi, yüzünüzü, saçınızı, giyim eşyalarınızı ve Elektrik Kordonunu, bütün hareket eden parça ve kısımlardan uzak tutun.*

J セットには、Battery PowerPack™ が1つ含まれています (電池は含まれていません)。モデルを組み立てる前に、電池を取り付けてください。手や顔、毛髪、衣類、電源コードを動いている部品に近づけないでください。

CHI 每套含 (1) 個 Battery PowerPack™ (不含電池)。請先安裝電池，再行拼裝。請將手、臉、頭髮、衣服和電線遠離所有會移動的零件。

IL הערכה כוללת סוללת PowerPack™ (1). (הסוללות אינן נכללות). התקן את הסוללות לפני הרכבת הדגמים. הרחק את הידיים, הפנים, השיער, הבגדים וחוט החשמל מכל החלקים הנעים.

Service Information in the USA and Canada

If your K'NEX PowerPack™ does not work, try new batteries. If it still does not work, call us at **1-800-KID-KNEX** (Monday thru Friday, 8:30 AM – 5:00 PM Eastern Standard Time). Please do not return the K'NEX PowerPack to the store or catalog house where it was purchased; they will not be able to help you.

USA (GB) Contains small parts. Not suitable for children under the age of 3 years.

F Contient des pièces de petite taille. Ne convient pas aux enfants de moins de 3 ans.

I A causa dei suoi piccoli componenti, questo giocattolo non è adatto a bambini di età inferiore ai 3 anni.

D Enthält kleine Teile und ist daher nicht für Kinder unter 3 Jahren geeignet.

E Debido a la presencia de piezas pequeñas, no se recomienda su uso para menores de 3 años.

S Innehåller smådelar. Ej lämpligt för barn under 3 år.

DK Ikke egnet for børn under 3 år pga. smådele.

N Inneholder smådelar. Egner seg ikke for barn under 3 år.

SF Varoituu! Ei sovelly alle 3-vuotiaille lapsille. Sisältää pieniä osia.

NL Bevat kleine onderdelen. Niet geschikt voor kinderen jonger dan 3 jaar.

P Devido às dimensões reduzidas de algumas peças, não é recomendado para crianças de idade inferior a 3 anos.

G Λόγω των μικρών εξαρτημάτων που περιέχουν, δεν είναι κατάλληλη για παιδιά μικρότερα των 3 ετών.

TR Küçük parçalardan dolayı 3 yaşından küçük çocuklar için uygun değildir.

J 細かい部品がありますので、3才以下のお子様には適しません。

CHI 內含極小零件，不適合3歲以下孩童。

IL מאחר והערכה מכילה חלקים קטנים, היא אינה מתאימה לילדים מתחת לגיל 3.

WARNING:
CHOKING HAZARD – Small Parts.
Not for Children under 3 years.



AVERTISSEMENT!
Danger d'étouffement. Pièces de petite taille.
Ne pas donner aux enfants de moins de 3 ans.

GB K'NEX is a registered trademark of K'NEX Industries, Inc. K'NEX International, Century House, Station Way, Cheam, Surrey, SM3 8SW, United Kingdom. FREEPHONE 0800 834938 (UK only)

F K'NEX est une marque déposée de K'NEX Industries, Inc. K'NEX France, ZA de la Plaisse, 73370 Le Bourget-du-Lac. Hasbro (Schweiz) AG, Alte Bremgartenstrasse 2, CH-8965 Berikon and S.A. Hasbro N.V., Riverside Business Park - Spey House, Bld International 55/4 Internationale Laan, Bruxelles 1070 Brussel.

I K'NEX è un marchio di fabbrica registrato della K'NEX Industries, Inc.

D K'NEX ist ein eingetragenes Warenzeichen der K'NEX Industries, Inc. K'NEX GmbH, Waldstraße 49, 90763 Fürth. Hasbro (Schweiz) AG, Alte Bremgartenstrasse 2, CH-8965 Berikon.

E K'NEX es una marca registrada de K'NEX Industries, Inc. Distribuido en España por M.B. España S.A. Apartado de Correos 133 Quart de Poblet-Valencia. N.I.F. A-46156444; R.I. 6170. Los colores de los componentes pueden diferir de los indicados en la caja. Recomendamos que guarde nuestra dirección por si le es necesaria más adelante.

S K'NEX är ett registrerat varumärke av K'NEX Industries, Inc. Hasbro Sweden AB, Johanneslundsvägen 2, Business Campus, S-194 81 Upplands Väsby.

DK K'NEX er et registreret varemærke, der tilhører K'NEX Industries, Inc. Hasbro Denmark A/S, Ejby Industrivej 40, DK-2600 Glostrup.

N K'NEX er et registrert varemerke som tilhører K'NEX Industries, Inc. Hasbro Norway AS, Nye Vakås Vei 64, N-1360 Nesbru.

SF K'NEX on K'NEX Industries, Inc. rekisteröimä tavaramerkki. Hasbro Finland OY, Vattuniemenranta 2, SF-00210 Helsinki.

NL K'NEX is een handelsmerk van de K'NEX Industries, Inc. Hasbro B.V., Smart Business Park, Kanaalweg 16 G, 3526 KL Utrecht. S.A. Hasbro N.V., Riverside Business Park - Spey House, Bld International 55/4 Internationale Laan, Bruxelles 1070 Brussel.

P K'NEX é uma marca registada da K'NEX Industries, Inc. Distribuido em Portugal por HASBRO, IMPORTAÇÃO e EXPORTAÇÃO DE JOGOS E BRINQUEDOS LDA, Rua Melo e Sousa, Bloco 2, Estoril Garden, 2765 Estoril. NIF 502949546. As cores dos componentes podem diferir das indicadas na caixa. Recomendamos que anotem a nossa morada para futura referência.

G Το K'NEX είναι σήμα κατατεθέν της K'NEX Industries, Inc.

TR K'NEX, K'NEX Industries, Inc.'in tescilli markasıdır. İNTERTOY tarafından ithal edilmiştir. PK 221, Şişli İstanbul.

J K'NEXは K'NEX Industries, Inc. の登録商標です。リサイクル紙使用。

CHI K'NEX 是 K'NEX Industries, Inc. 的注册商標。香港九龍尖沙嘴廣東道七號海港城世運中心一五零六室 Palmyra (香港) 有限公司台灣分公司, 台北縣砂板鎮中興路九十五號五樓二室。

IL K'NEX Industries, Inc. הוא סימן מסחרי רשום של הסברו ישראל בע"מ, שדרות הרצל 104, ירושלים 96187

©1998 K'NEX Industries, Inc. • Hatfield, PA 19440-0700 • 1-800-KID-KNEX (USA & CANADA)

Visit K'NEX at www.knex.com

K'NEX is a registered trademark of K'NEX Industries, Inc. Manufactured under U.S. Patents 5,061,219, 5,137,486, 5,199,919, 5,238,438, 5,346,420, 5,350,331, 5,368,514, 5,421,762, 5,423,707, 5,427,559, 5,518,435, D389,203 and D391,1921. Other U.S. and foreign patents pending.

Conforms to the Requirements of ASTM Standard Consumer Safety Specification on Toy Safety F963-96a.

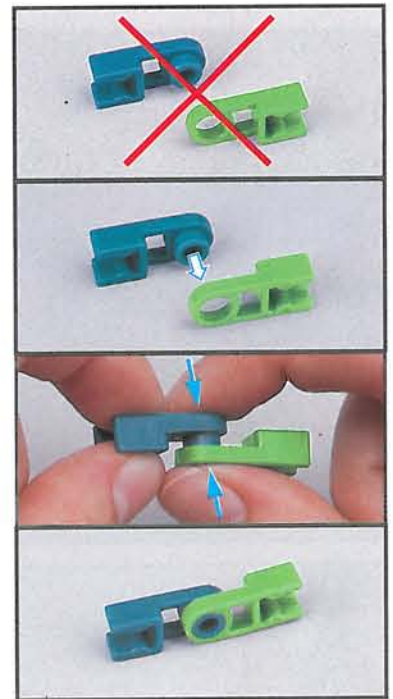
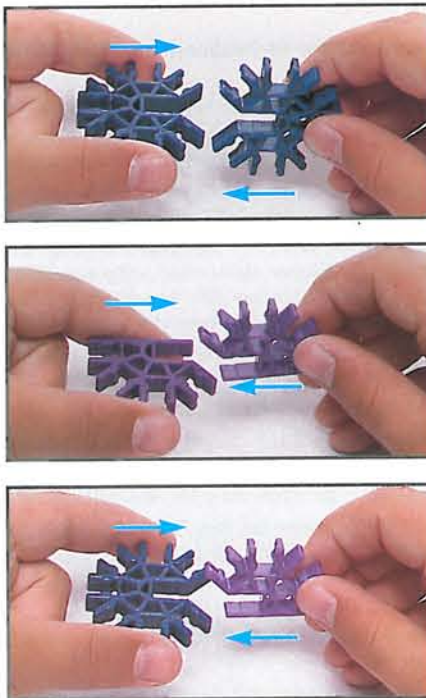
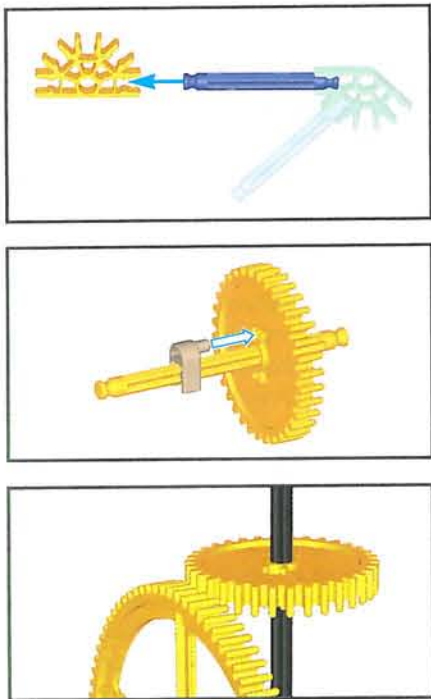

USA (GB) BUILDING TIPS: Each K'NEX piece has its own color (colour) and shape; match it to pieces in the picture instructions. Put pieces together exactly as pictures show. Faded colors (colours) indicate sections previously built; connecting points will be in full color (colour).

- Be sure to put Rods in the correct slots of Connectors, so you have proper angles in your finished model.
- It's very important to position blue and purple Connectors in a specific direction. Pay close attention to the instructions, and position these Connectors horizontally or vertically exactly as they are shown. Push together tightly until you hear a "click".
- Teeth of gears need to line up properly for model to work.

F CONSEILS D'ASSEMBLAGE: Chaque pièce K'NEX a une couleur et une forme bien à elle. Faites correspondre et montez les pièces les unes sur les autres en suivant exactement les instructions illustrées. Les couleurs plus claires indiquent les sections déjà construites. Les points de jonction sont indiqués en couleurs vives.

- Assurez-vous de bien assembler les tiges dans les fentes des connecteurs afin d'obtenir des angles corrects une fois le modèle fini.
- Il est important de bien placer les connecteurs bleus et violets dans le bon sens. Lisez attentivement les instructions et placez ces connecteurs horizontalement ou verticalement selon l'indication. Appuyez dessus en forçant légèrement jusqu'à ce que vous entendiez un dé clic.
- Les dents des roues doivent être bien alignées pour permettre au modèle de bien fonctionner.

I CONSIGLI PER LA COSTRUZIONE: Ogni componente K'NEX è dotato di colore e forma caratteristici; basta seguire le istruzioni illustrate, mettendo i pezzi esattamente nella sequenza raffigurata. I colori schiariti indicano le sezioni costruite in precedenza; i punti di collegamento sono in colore vero.

- Assicurarsi di aver inserito le aste negli opportuni fori dei connettori, in modo che il modello finito presenti le angolature corrette.
- È particolarmente importante mettere i connettori azzurri e porpora in una particolare posizione. Facendo bene attenzione alle istruzioni, occorre fissarli in una precisa posizione orizzontale o verticale, esattamente come nell'illustrazione, spingendoli uno verso l'altro fino a udire uno scatto.
- Perché il modello possa funzionare, i denti degli ingranaggi devono essere allineati correttamente.

D TIPS ZUM ZUSAMMENBAUEN: Jedes K'NEX-Teil hat seine eigene besondere Farbe und Form; vergleichen Sie jedes Teil mit denen auf den Abbildungen. Die Teile genau wie auf den Abbildungen dargestellt zusammenbauen. Die farblich heller gekennzeichneten Teile zeigen bereits zusammengebaute Abschnitte an. Die Anbringungspunkte sind in kräftigen Farben dargestellt.

- Achten Sie darauf, daß Sie die Stangen in die richtigen Schlitze des Verbindungsstücks einsetzen, damit Sie am Ende der Montage die richtigen Winkel erhalten.
- Es ist äußerst wichtig, die blauen und lila Verbindungsstücke in einer speziellen Richtung anzubringen. Folgen Sie genau den Anweisungen, und bringen Sie die Verbindungsstücke den Abbildungen entsprechend entweder horizontal oder vertikal an. Drücken Sie sie fest zusammen, bis Sie ein deutliches „Klick“ hören.
- Die Zacken der Zahnräder müssen ineinandergreifen, damit das Modell ordnungsgemäß funktioniert.

E SUGERENCIAS: Cada una de las piezas K'NEX tiene su propio color y forma especiales, los cuales se deben hacer coincidir con las piezas de los dibujos de las instrucciones. Colocar las piezas exactamente como se muestra en los dibujos. Los colores apagados indican secciones que ya han sido montadas anteriormente. Los puntos de conexión se indican con colores vivos.

- Asegurarse de colocar las varillas en las ranuras correctas de los conectores, de modo que al terminar el modelo, los ángulos sean los adecuados.
- Es muy importante colocar los conectores de color azul y morado en una dirección específica. Prestar mucha atención a las instrucciones y colocar estos conectores según se indica, ya sea horizontal o verticalmente. Para conectarlos, presionar hasta oír un "clic".
- Para que el modelo funcione, los dientes de los engranajes deben alinearse correctamente.

S BYGGTIPS: Varje K'NEX-del har en speciell färg och form. Matcha med delarna i bildanvisningarna. Sätt ihop delarna precis som visas på bilderna. Blekare färger representerar redan byggda sektioner. Anslutningspunkter visas i helfärg.

• Det är mycket viktigt att ställa in de blå och lila anslutningarna i rätt läge. Observera anvisningarna noggrant och ställ in anslutningarna horisontellt eller vertikalt precis som på bilden. Tryck samman ordentligt tills ett "klickljud" hörs.

• Kugghjulständerna måste riktas in för att modellen ska fungera.

DK BYGGETIPS: Alle K'NEX dele har forskellig farve og form; find hver enkelt del på illustrationen, og sæt delene sammen, nøjagtigt som illustrationen viser. Svagere farver viser dele, som er sat sammen på forhånd; samlepunkterne vises i fuld farve.

- Det er vigtigt at stængerne sættes i de rette slidser på samlestykkerne, så vinklerne bliver rigtige på den færdige model.
- Det er meget vigtigt, at de blå og lilla samlestykker vender i en bestemt retning. Følg instruktionerne nøje, og anbring disse samlestykker vandret eller lodret nøjagtigt, som vist på illustrationen. Tryk delene godt sammen, til der lyder et klik.
- Tænderne på tandhjulene skal være korrekt rettet ind, for at modellen skal kunne fungere.

N BYGGETIPS: Hver K'NEX-del har en særegen form og farge. Finn de samsvarende delene i bildeinstruksjonene. Sett delene sammen akkurat slik bildene viser. Svakerer farger angir deler som allerede er bygget. Koblingspunktene vises med full farge.

- Pass på at du setter stengene i de rette sporene på koblingene, slik at vinklene blir riktige på den ferdige modellen.
- Det er veldig viktig å plassere de blå og lilla koblingene i en bestemt retning. Følg instruksjonene nøye, og plasser koblingene vannrett eller lodrett nøyaktig som vist. Press delene godt sammen inntil du hører et klikk.
- Tennene på tannhjulene må være riktig innrettet for at modellen skal kunne fungere.

SF RAKENNUSVINKKEJÄ: Jokainen K'NEX-pala on erivärinen ja -muotoinen. Kiinnitä palat ohjeissa kuvattuihin osiin. Yhdistä palat toisiinsa täsmälleen kuvissa näytetyllä tavalla. Haaleat värit kuvaavat mallin aikaisemmin koottuja osia ja liitäntäkohdat on esitetty kirkkailla väreillä.

- Varmista, että sijoitat sauvat liittimien oikeisiin reikiin, jotta valmiin mallin kulmat ovat oikein.
- On tärkeää, että asetat siniset ja violetit liittimet oikein päin. Noudata ohjeita tarkkaan ja aseta liittimet vaakasuoraan tai pystysuoraan ohjeissa esitetyllä tavalla. Napsauta ne yhteen.
- Hammaspyörien hampaiden on asetettava lomittain, jotta malli toimisi.

NL BOUWTIPS: Elk K'NEX-stuk heeft zijn eigen speciale kleur en vorm; vergelijk ze met de stukken in de illustraties. Zet de onderdelen precies zo in elkaar als in de illustratie wordt aangegeven. Verbleekte kleuren geven de eerder gebouwde gedeeltes aan; de aansluitpunten worden in felle kleuren weergegeven.

- Zorg ervoor dat de stangen in de juiste sleuven van de connectors worden gestopt zodat je de juiste hoeken krijgt in het voltooid model.
- Het is heel belangrijk dat de blauwe en paarse connectors in een specifieke richting worden geplaatst. Let goed op de aanwijzingen en plaats deze verbindingstukken precies zo horizontaal of verticaal als ze worden getoond. Duw ze stevig in elkaar tot je een "klik" hoort.
- De tanden van de tandwielen moeten goed uitgelijnd zijn anders werkt het model niet.

P SUGESTÕES PARA CONSTRUÇÃO: Cada peça K'NEX tem a sua própria cor e forma especiais. Encaixe estas peças de forma idêntica à mostrada nas instruções ilustradas, exactamente conforme ilustrado. As cores esbatidas indicam seções previamente construídas. Os pontos de ligação são apresentados em cores sólidas.

- Certifique-se de encaixar as hastas nos orifícios correctos dos dispositivos de ligação, de forma a obter ângulos adequados no seu modelo final.
- É muito importante colocar os dispositivos de ligação azuis e roxos numa determinada direcção. Tenha atenção às instruções e posicione estes dispositivos de ligação horizontal ou verticalmente, exactamente conforme mostrado. Pressione-os bem até ouvir um estalido.
- Os dentes das engrenagens têm de estar correctamente alinhados para o modelo poder funcionar.

G ΣΥΜΒΟΥΛΕΣ ΚΑΤΑΣΚΕΥΗΣ: Κάθε κομμάτι K'NEX έχει το δικό του χρώμα και σχήμα. Ταυριάζετε το με τα κομμάτια που φαίνονται στις φωτογραφίες. Ενώστε τα κομμάτια όπως ακριβώς δείχνουν οι φωτογραφίες. Τα ξεθωριασμένα χρώματα υποδεικνύουν τα τμήματα που έχετε ήδη κατασκευάσει. Τα σημεία σύνδεσης φαίνονται με κανονικό χρώμα.

- Τοποθετήστε τις ράβδους στις σωστές υποδοχές των συνδετικών τμημάτων για να έχετε καλές γωνίες στο συναρμολογημένο μοντέλο.

- Πρέπει να τοποθετείτε τα μπλε και μωβ συνδετικά τμήματα στη κατάλληλη κατεύθυνση. Διαβάστε προσεκτικά τις οδηγίες και τοποθετείστε τα συνδετικά τμήματα οριζόντια ή κάθετα όπως ακριβώς φαίνονται. Πιέστε τα σφιχτά μέχρι να ακούσετε ένα "κλικ".
- Τα δόντια των γραναζιών πρέπει να είναι ευθυγραμμισμένα σωστά για να λειτουργήσει το μοντέλο.

TR MONTAJ İÇİN TAVSİYELER: Her bir K'NEX parçasının kendine özgü özel renk ve şekli vardır; bu parçaları teker teker resimli açıklamadaki parçalara bakarak eşleştirin. Parçaları tam resimlerde görüldüğü gibi biraraya getirin. Soluk renkler daha önce monte edilmiş kısımları göstermektedir. Birleştirilecek noktalar (daha koyu olan) tam renkle gösterilmiştir.

- Bitmiş modelinizdeki açıkların doğru olabilmesi için, Çubukları Birleştiricilerin doğru oyuklarına geçirmiş olmaya dikkat edin.
- Mavi ve mor Birleştiricilerin belirli bir yönde yerleştirilmeleri çok önemlidir. Açıklamalara çok dikkat edin ve bu Birleştiricileri aynen resimde görüldüğü şekilde yatay ve dikey olarak yerleştirin. Bunları, «tik» sesi verinceye kadar, yani birbirine sıkıca geçinceye kadar ittirin.
- Modelin çalışabilmesi için, dişli çarkları üzerindeki dişlerin doğru olarak hizalanmaları gerekir.

J 組み立て上の注意 K'NEXの各部品は、それぞれカラーや形状が異なります。各部品を説明図と照らし合わせて確認してください。部品は説明図にしたがって正しく組み合わせてください。薄いカラーで表示されている部分は、すでに組み立てられた部分です。接続する部分は、実際のカラーで示されています。

- 完成モデルが正しい角度を保つよう、ロッドはコネクタの適切なスロットに差し込んでください。
- ブルーとパープルのコネクタは、必ず適切な角度で取り付けてください。説明書をよく見て、図のように水平または直角に正しくコネクタを取り付けてください。取り付けの際には、カチッと音がするまでしっかりと押し込んでください。
- モデルを正しく機能させるためにギアの歯の位置を合わせてください。

CHI 建造提示: 每一塊 K'NEX 零件有特别的顏色和形狀; 將這些零件與圖片說明的組合片對上。依圖片將零件逐一組合起來。淺色的部份表示已拼裝好; 接合點會以全色顯示。

- 將連接桿放在連接的正確位置, 這樣的模型才會有恰當的角度。
- 一定要將藍色和紫色連接器朝著指定的方向。請詳閱說明。小心將此兩種連接器按說明中的水平或垂直方向放置, 用力將其推緊直到聽到“喀噠聲”。
- 齒輪的齒必須恰當排列, 模型才可操作。

IL טיפים לבניה. לכל חלק של K'NEX צבע וצורה מיוחדים לו. התאם אותם לחלקים המופיעים בתמונות שבהוראות. חבר את החלקים בדיוק שפי שרואים בתמונות. צבעים זהויים מצביעים על חלקי דגם שכבר נבנו קודם לכן. נקודות החיבור מופיעות בצבעים מלאים.

- הקפד להכניס את המוטות לחריצים המתאימים של המחברים, כדי שהזוויות של הדגם הסופי תהיינה תואמות.
- חשוב מאד למקם את המחברים הכחולים והסגולים בכיוון מסוים. הקפד על ההוראות, ומקם את המחברים האלה במאוזן או במאונך, בדיוק כפי שהם מופיעים בתמונות. הצמד אותם יחדיו, עד שתשמע "קליק".
- גלגלי השיניים צריכים להיות מכוונים כחלכה, כדי שהדגם יפעל.



USA (GB) Keep this important information for future reference.

- Do not connect model to more than one PowerPack™.
- Remove rechargeable batteries from model before charging; they must be charged only under adult supervision.
- Non-rechargeable batteries must not be recharged.
- Do not mix different types of batteries; do not mix alkaline, standard (carbon-zinc), or rechargeable (nickel-cadmium) batteries. Do not mix new and used batteries. Only batteries of the same or equivalent type recommended should be used.
- Insert batteries with correct polarity (+/-) as shown.
- Remove exhausted batteries from model; do not short-circuit supply terminals.
- Keep PowerPack™ free of dust; do not immerse or use in water.
- Alkaline batteries AA (LR6) are recommended.
- Do not put small green Rods in any openings of the PowerPack™; they will damage the motor, and cannot be removed.

F Conservez ces renseignements pour utilisation ultérieure.

- Ne branchez pas la maquette à plus d'un PowerPack™.
- Enlevez les piles rechargeables de la maquette avant de les charger. Elles ne doivent être chargées que sous la supervision d'un adulte.
- Les piles non rechargeables ne doivent pas être rechargées.
- Ne mélangez pas les différents types de piles. Ne mélangez pas les piles alcalines, les piles standard (zinc-carbone) ni les piles rechargeables (nickel-cadmium). Ne mélangez pas des piles neuves et des piles usées. Il est recommandé de n'utiliser que des piles du même type ou de type équivalent.
- Insérez les piles en respectant la polarité (+/-), comme illustré.
- Enlevez les piles usées de la maquette et prenez soin de ne pas court-circuiter les bornes des piles.
- Maintenez le PowerPack™ propre et sans poussière. Ne l'immergez pas et ne l'utilisez pas dans l'eau.
- Il est recommandé d'utiliser des piles alcalines AA (LR6).
- Ne mettez pas les petites tiges vertes dans les trous du PowerPack™, elles endommageraient le moteur et il n'est pas possible de les enlever.

I Conservate queste importanti informazioni per riferimenti futuri.

- Non collegate il modello a più di un PowerPack™.
- Prima di ricaricare le pile ricaricabili, estraetele dal modello. Le pile vanno ricaricate solo sotto la supervisione di adulti.
- Le pile non ricaricabili non vanno ricaricate.
- Non mescolate tipi diversi di pile, come le pile alcaline, quelle normali (carbone-zinco) o quelle ricaricabili (nickel-cadmio). Non mescolate pile nuove ed usate. Vanno utilizzate solo le pile del tipo raccomandato o di tipo equivalente.
- Inserite le pile secondo la giusta polarità (+/-) come illustrato.
- Togliete dal modello le pile esaurite; non cortocircuitate i terminali dell'alimentatore.
- Non esponete alla polvere il PowerPack™ e non usatelo né immergetelo nell'acqua.
- Si raccomandano le pile alcaline AA (LR6).
- Non inserite le piccole aste verdi nelle aperture del PowerPack™, in quanto non potranno venire rimosse e danneggeranno il motore.

D Diese wichtigen Informationen zum Nachschlagen gut aufbewahren.

- Das Modell an nicht mehr als ein PowerPack™ anschließen.
- Aufladbare Batterien vor dem Laden aus dem Modell entfernen; sie dürfen nur unter der Aufsicht von Erwachsenen geladen werden.
- Nicht aufladbare Batterien dürfen nicht wieder aufgeladen werden.
- Keine verschiedenen Batterientypen mischen; Alkalibatterien, Standard- (Kohlenstoff-Zink-) oder aufladbare (Nickel-Kadmium) Batterien nicht mischen. Keine neuen undgebrauchten Batterien mischen. Nur Batterien vom gleichen oder empfohlenen gleichwertigen Typ sollten verwendet werden.
- Die Batterien laut Abbildung mit der korrekten Polarität (+/-) einsetzen.
- Die leeren Batterien aus dem Modell nehmen; die Versorgungsklemmen nicht kurz schließen.
- Das PowerPack™ staubfrei halten; es darf nicht in Wasser eingetaucht oder benutzt werden.
- Wir empfehlen die Verwendung von Alkalibatterien AA (LR6).
- In keine der Öffnungen des PowerPack™ kleine grüne Stangen einsetzen; sie beschädigen den Motor und können nicht entfernt werden.

E Guarde esta importante información para consultarla más adelante.

- No conecte el modelo a más de un PowerPack™.
- Saque las pilas recargables del modelo antes de cargarlas; solamente deben cambiarse con la supervisión de una persona adulta.
- Las pilas no recargables no deben recargarse.
- No mezcle diferentes tipos de pilas; no mezcle pilas alcalinas, estándar (carbón-zinc) o recargables (níquel-cadmio). No mezcle las pilas nuevas y las usadas. Solamente deben usarse pilas del mismo tipo recomendado o equivalente.
- Inserte las pilas con los polos (+/-) en posición correcta, tal como se indica.
- Saque del modelo las pilas gastadas; asegúrese de no provocar un cortocircuito en el terminal de alimentación.
- Mantenga el PowerPack™ libre de polvo; no lo sumerja ni lo use en agua.
- Se recomiendan baterías alcalinas AA (LR6).
- No meta las varillas verdes pequeñas en los orificios del PowerPack™, ya que dañarían el motor y no se podrían sacar.

S Behåll denna viktiga information för framtida bruk.

- Koppla inte modellen till mer än en PowerPack™.
- Avlägsna laddningsbara batterier från modellen före laddning; de måste laddas under översikt av vuxna.
- Batterier som inte kan laddas om får inte laddas om.
- Kombinera inte olika sorters batterier; blanda inte alkaliska batterier, standardbatterier (kol/zink) eller laddningsbara batterier (nickel/kadmium). Kombinera inte nya och använda batterier. Du bör endast använda batterier av den typ som rekommenderats, eller likvärdig typ.
- Sätt in batterierna med korrekt polaritet (+/-) enligt anvisning.
- Avlägsna nedgångna batterier från modellen; undvik kortslutning vid kontakterna.
- Se till att PowerPack™ inte blir dammig; doppa inte och använd inte i vatten.
- Alkaliska batterier AA (LR6) rekommenderas.
- Placera inga små gröna stänger i några som helst öppningar i PowerPack™; de skadar motorn och kan inte avlägsnas.

DK Gem disse vigtige oplysninger som fremtidig reference.

- Modellen må ikke forbindes med mere end én PowerPack™.
- Tag genopladelige batterier ud af modellen inden de lades op. De må kun oplades under tilsyn af voksne.
- Ikke-genopladelige batterier må aldrig genoplades.
- Batterityperne må ikke blandes. Bland aldrig alkaliske, standard (kulstof-zink) eller genopladelige (nikkel-cadmium) batterier. Bland aldrig nye og brugte batterier. Der bør kun benyttes batterier af samme eller anbefalet tilsvarende type.
- Sæt batterierne i ifølge den viste polaritet (+/-).
- Fjern udslidte batterier fra modellen; polerne må ikke kortsluttes.
- PowerPack™ skal holdes fri af støv og må ikke dypes eller bruges i vand.
- Alkaliske batterier AA (LR6) anbefales.
- De små grønne stænger må ikke stikkes i nogen af åbningerne på PowerPack™. De vil ødelægge motoren og kan ikke tages ud.

N Ta vare på disse viktige opplysningene.

- Modellen skal ikke koples til mer enn én PowerPack™.
- Ta oppladbare batterier ut av modellen før batteriene lades opp. Opplading av batterier må kun skje under oppsyn av voksne.
- Prøv ikke å lade opp batterier som ikke er oppladbare.
- Bruk ikke batterier av ulike typer samtidig. Alkaline-batterier, standard (karbon-sink) batterier eller oppladbare batterier (nikkel-kadmium) må ikke blandes. Nye og brukte batterier bør heller ikke brukes samtidig. Batteriene bør kun være av samme type eller tilsvarende type.
- Sett batteriene inn med riktig polaritet (+/-), slik som vist.
- Ta oppbrukte batterier ut av modellen. Pass på at du ikke kortslutter forsyningsterminalene.
- Sørg for at PowerPack™ er fri for støv. PowerPack skal ikke senkes eller brukes i vann.
- Alkaline-batterier AA (LR6) anbefales.
- Du må ikke stikke små grønne stenger inn i noen av åpningene på PowerPack™. Stengene vil ikke kunne fjernes og kan skade motoren.

SF Säilytä nämä tärkeät tiedot myöhempiä tarvetta varten.

- Älä liitä mallia useampaan kuin yhteen voimaysikköön.
- Poista ladattavat paristot mallista ennen niiden latausta; ne on ladattava ainoastaan aikuisten valvonnan alla.
- Ei-ladattavia paristoja ei saa ladata uudelleen.
- Älä sekoita eri tyypisiä paristoja; älä sekoita keskenään alkaliparistoja tavallisia (hiili-sinkki) tai ladattavia (nikkeli-kadmium) paristoja. Älä käytä sekaisin uusia ja käytettyjä paristoja. Vain saman tai vastaavan tyypisiä paristoja saa käyttää.
- Pane sisään paristot polaarisesti oikein (+/-) kuten näytetään.
- Poista kuluneet paristot mallista; älä aiheuta oikosulkua syöttöliittimiin.
- Pidä voimaysikkö pölyvapaana; älä upota sitä veteen tai käytä sitä vedessä.
- Suosittelemme alkaliparistoja AA (LR6).
- Älä pane pieniä vihreitä sauvoja mihinkään voimaysikön reikään, ne vahingoittavat moottoria ja niitä ei voi poistaa.

NL Bewaar deze belangrijke informatie voor later.

- Sluit het model niet op meer dan één PowerPack™ aan.
- Verwijder de oplaadbare batterijen uit het model om ze op te laden; ze mogen alleen onder toezicht van een volwassene worden opgeladen.
- Niet-oplaadbare batterijen mogen niet opnieuw worden opgeladen.
- Verschillende soorten batterijen niet door elkaar gebruiken; geen alkalische, standaard (koolzink) of oplaadbare (nikkel-cadmium) batterijen door elkaar gebruiken. Geen nieuwe en gebruikte batterijen door elkaar gebruiken. Alleen batterijen van hetzelfde of soortgelijk aanbevolen type mogen worden gebruikt.
- Plaats batterijen met de juiste polariteit (+/-) zoals aangegeven.
- Lege batterijen uit het model halen; voedingsklemmen niet kortsluiten.
- Het PowerPack™ stofvrij houden; niet onderdompelen of in water gebruiken.
- Alkali-batterijen AA (LR6) worden aanbevolen.
- Plaats geen groene staafjes in de openingen van het PowerPack™; zij zouden de motor beschadigen en kunnen niet worden verwijderd.

P Guarda estas importantes instruções para referência futura.

- Não ligue o modelo a mais do que um PowerPack™.
- Retira as pilhas recargáveis do modelo antes de iniciar a recarga; as pilhas só deverão ser recargadas na presença de um adulto.
- Não se deve tentar fazer a recarga de pilhas não recargáveis.
- Não misture pilhas de tipos diferentes. Não juntes as pilhas alcalinas com as normais (de carvão e zinco) ou com as pilhas recargáveis (de níquel-cadmio). Não misture as pilhas novas com as gastas. Apenas deverão ser utilizadas as baterias do tipo recomendado ou equivalente.
- Instala as baterias na posição correcta (pólos + e -) como mostra a gravura.
- Retira as pilhas gastas do modelo; não ligue os terminais em curto-circuito.
- Mantém o PowerPack™ limpo de poeiras; não o coloques nem o utilizes na água.
- Recomenda-se o uso de pilhas alcalinas AA (LR6).
- Não coloques as pequenas hastas verdes em qualquer abertura do PowerPack™; elas danificariam o motor e não poderiam ser removidas.

G Φυλάξτε αυτές τις σημαντικές πληροφορίες για μελλοντική χρήση.

- Μη συνδέετε το μοντέλο με περισσότερα από ένα PowerPack™.
- Αφαιρείτε τις επαναφορτιζόμενες μπαταρίες από το μοντέλο πριν τις φορτίσετε. Πρέπει να φορτίζονται μόνο υπό την επίβλεψη ενηλίκου.
- Μη επαναφορτιζόμενες μπαταρίες δεν πρέπει να επαναφορτίζονται.
- Μην αναμειγνύετε διαφορετικούς τύπους μπαταριών. Μην αναμειγνύετε αλκαλικές, συνήθεις (άνθρακα-ψευδαργύρου), ή επαναφορτιζόμενες (νικελίου-καδμίου) μπαταρίες. Μην αναμειγνύετε καινούριες και μεταχειρισμένες μπαταρίες. Μόνο μπαταρίες του ίδιου ή ανάλογου συνιστώμενου τύπου πρέπει να χρησιμοποιούνται.
- Τοποθετήστε τις μπαταρίες με τη σωστή πολικότητα (+/-) όπως δείχνει το σχήμα.
- Αφαιρείτε τις εξαντλημένες μπαταρίες από το μοντέλο. Μη βραχυκυκλώνετε τους ακροδέκτες παροχής ρεύματος.
- Διατηρείτε το PowerPack™ μακριά από σκόνη. Μην το βυθίζετε ούτε να το χρησιμοποιείτε μέσα στο νερό.
- Συνιστώνται αλκαλικές μπαταρίες AA (LR6).
- Μη βάλετε τις μικρές πράσινες ράβδους σε κανένα από τα ανοίγματα του PowerPack™. Θα προκαλέσουν βλάβη στο μοτέρ, και δε βγαίνουν.

CHI 保留這份重要資料供今後參考。

- 不要將模型連接到一個以上的電池盒 (PowerPack™) 上。
- 在電池充電前，先將可充電電池從模型上取出，並只能在成人指導下充電。
- 非可充電型電池不能充電。
- 不要將不同型式的電池混合使用，不要混合使用鹼性的、標準的 (碳 - 鋅)，或可充電的 (鎳 - 鎘) 電池。不要混合使用新舊電池。應只用和推薦的相同或相當型式的電池。
- 裝電池時要按照圖示的正確極性 (+/-) 裝入。
- 電池耗盡後應從模型上取出，不要將供電端短路。
- 電池盒 (PowerPack) 上不要有灰塵，也不要浸入水中或在水中使用。
- 推薦使用鹼性電池 (LR6)。
- 不要將綠色小桿插入電池盒 (PowerPack) 的任何孔內。它們會損壞馬達，而且會再也拿不出來。

J 以下は重要な注意事項です。今後の参照用に保管してください。

- モデルは複数のPowerPackに接続しないでください。
- 充電用バッテリーは、モデルから取り外した後で充電してください。バッテリーの充電は、大人が見ているところで行ってください。
- 充電用でないバッテリーは、決して充電しないでください。
- アルカリバッテリー、通常のバッテリー（炭素鉛）、充電用バッテリー（ニッケル=ニッケルカドミウム）など、異なる種類のバッテリーを一緒に使用しないでください。また、新しいバッテリーと古いバッテリーを一緒に使用しないでください。推奨されている同一または同等のバッテリーのみを使用してください。
- バッテリーは、電極（+および-極）の向きを正しく確認して挿入してください。
- 使い古したバッテリーはモデルから取り外し、電源ターミナルの漏電を避けてください。
- PowerPackに埃が付かないようにしてください。また、水に浸したり、水中で使用しないでください。
- アルカリバッテリー AA (LR6) の使用をお勧めします。
- グリーン色のロッドは、PowerPackの開口部に差し込まないでください。これらのロッドはモーターを損傷し、後で取り外しできません。

TR Bu önemli bilgiyi ileride de kullanmak için saklayın.

- Modeli birden fazla PowerPack e bağlamayın.
- Şarj edilebilir pilleri modelden çıkardıktan sonra şarj edin; şarj işlemi ancak yetişkin bir kişinin gözetimi altında yapılmalıdır.
- Şarj edilemeyen normal piller şarj edilmemelidir.
- Değişik türden olan pilleri birbirine karıştırmayın; alkalın, standart (karbon-çinko), veya şarj edilebilir (nikel-kadmiyum) pilleri birbirine karıştırmayın. Yeni ve eski pilleri birbirine karıştırmayın. Sadece tavsiye edilen veya benzeri türdeki piller kullanılmalıdır.
- Pillerin kutuplarını (+/-) gösterildiği şekilde doğru olarak takın.
- Bitmiş pilleri modelden çıkarın; kutupları kısa devre yaptırmayın.
- PowerPack'in tozlanmamasına dikkat edin; suyun içine sokmayın veya suda kullanmayın.
- Alkalın piller AA (LR6) tavsiye edilir.
- Küçük yeşil Çubukları PowerPack'in oyuklarına sokmayın; onlar motora hasar verirler ve sonra da çıkarılmaları mümkün değildir.

IL שמור על מידע חשוב זה, לצורך עיון בעתיד.

- אל תחבר את הדגם ליותר מ-PowerPack אחד.
- הוצא מהדגם סוללות הניתנות לטעינה לפני הטעינה. יש לטעון סוללות בפיקוח אדם מבוגר בלבד.
- אין לטעון סוללות שאינן ניתנות לטעינה.
- על תערבב סוגים שונים של סוללות. אל תערבב סוללות מסוג אלקלין, סוללות סטנדרנטיות (פחם-אבץ) או סוללות הניתנות לטעינה (ניקל-קדמיום). אל תערבב סוללות חדשות ומשומשות. השתמש אך ורק בסוללות מהסוג המומלץ או מסוג בעל תכונות זהות.
- הכנס את הסוללות בכיוון הנכון (+/-), כפי שמראים בתמונה.
- הוצא סוללות מרוקנות מהדגם. אל תגרום לקצר במגעו ספק הכוח.
- שמור על ה-PowerPack, כך שיהיה נקי מאבק. אל תכניסו אל תוך מים ואל תשתמש בו בתוך מים.
- מומלץ להשתמש בסוללות מסוג אלקלין (LR6)
- אל תכניס מוטות ירוקים קטנים אל תוך פתחים כלשהם ב-PowerPack. מוטות אלה יגרמו נזק למנוע, ולא ניתן להוציאם.

COMMANDER

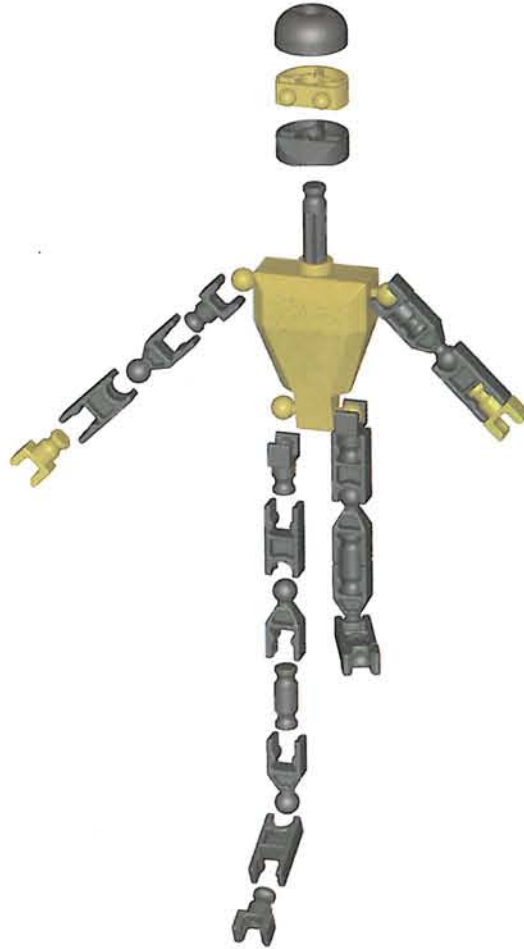
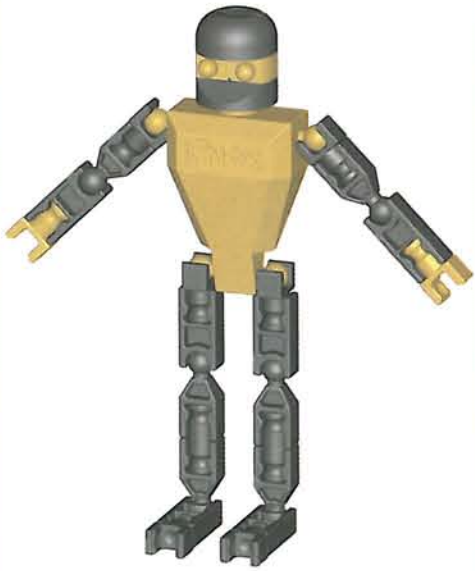

USA (GB) Push to snap together.	SF Napsauta osat kiinni toisiinsa.
F Enfoncez les pièces pour les imbriquer.	NL Druk op de onderdelen om ze in elkaar te klemmen.
I Spingere per incastrare.	P Empurre para encaixar.
D Teile zum Verbinden zusammenstecken.	G Πιέστε για να τα ενώσετε.
E Empuja las piezas para que encajen a presión.	TR İttirerek birbirine birleştirin.
S Tryck ihop delarna tills de låses samman.	J 押しながらはめ込みます。
DK Skub delene ind i hinanden, til de siger klik.	CHI 將兩邊嗒嗒一聲推在一起。
N Skyv delene mot hverandre til de låses sammen.	IL לחיבור החלקים, לחץ.

USA (GB) Options

- | | | | | | | | |
|-----------------------------------|------------------------|----------------------|------------------------|-------------------------|-------------------------|----------------------|--------------------|
| F Différentes possibilités | D Möglichkeiten | S Alternativ | N Alternativer | NL Mogelijkheden | G Διάφορα Σχεδία | TR Seçenekler | |
| I Combinazioni possibili | E Opciones | DK Samlemåder | SF Vaihtoehtoja | P Opções | J 別の組み合わせ方 | CHI 其它選擇 | IL אפשרויות |

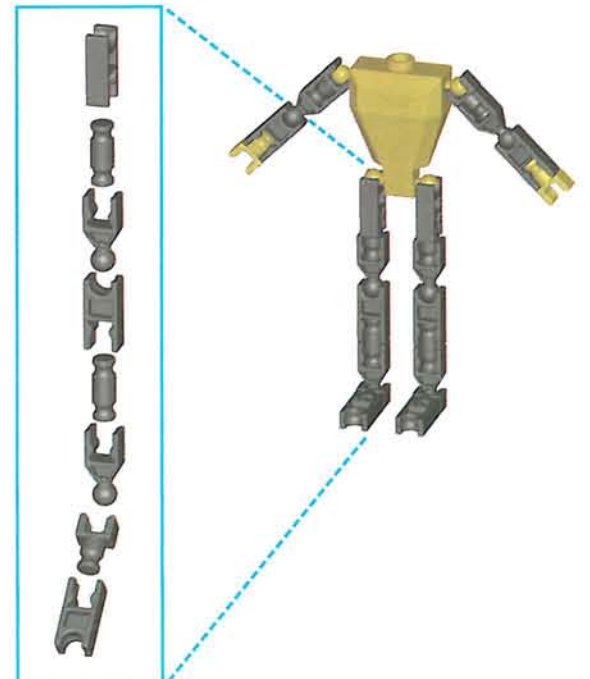
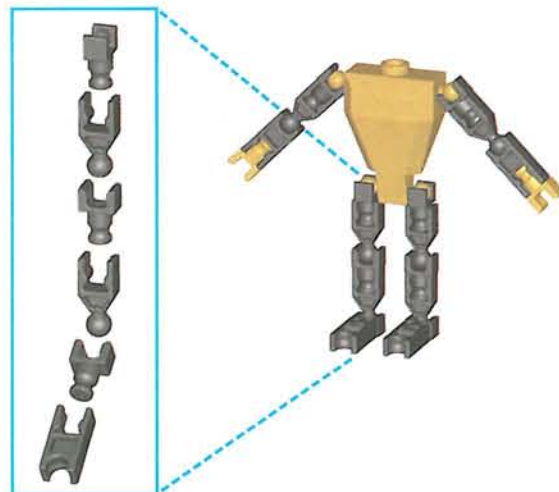

HYPERSPACE TRAINING TOWER

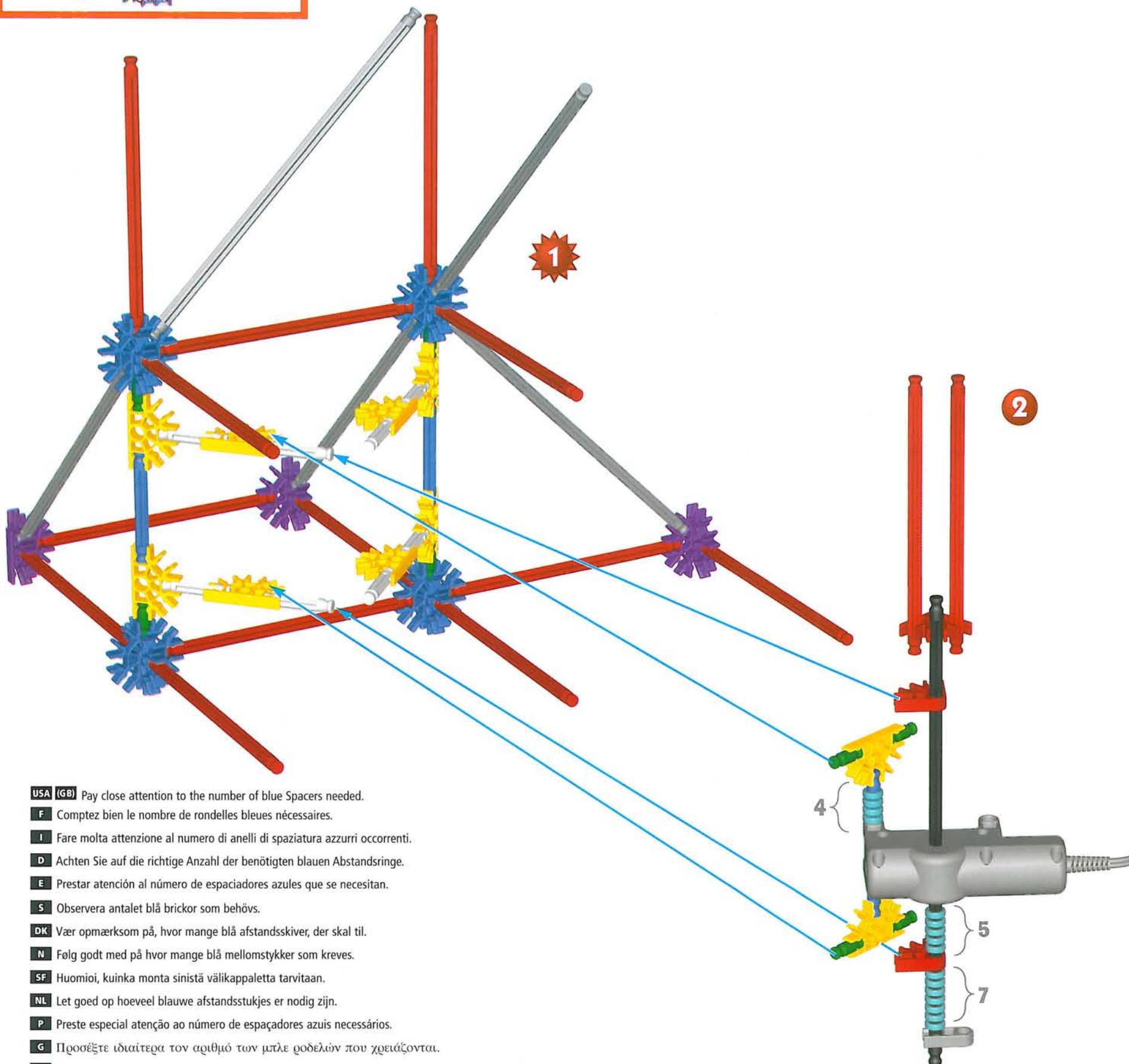
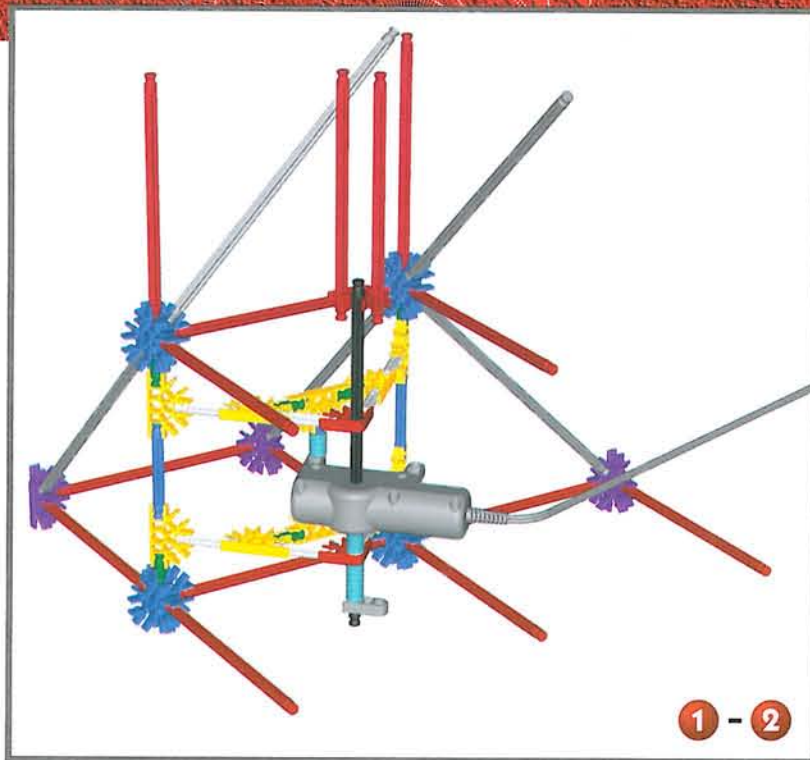
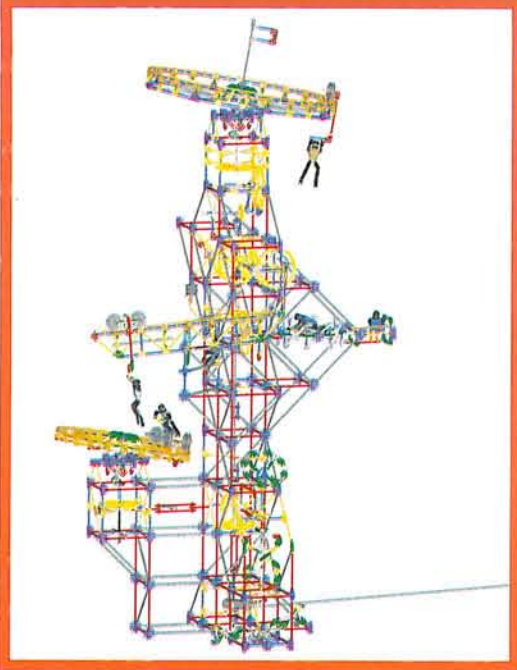

USA (GB) Pay close attention to the number of blue Spacers needed.

F Comptez bien le nombre de rondelles bleues nécessaires.

I Fare molta attenzione al numero di anelli di spaziatura azzurri occorrenti.

D Achten Sie auf die richtige Anzahl der benötigten blauen Abstandsringe.

E Prestar atención al número de espaciadores azules que se necesitan.

S Observera antalet blå brickor som behövs.

DK Vær opmærksom på, hvor mange blå afstandskiver, der skal til.

N Følg godt med på hvor mange blå mellomstykker som kreves.

SF Huomioi, kuinka monta sinistä välikappaleita tarvitaan.

NL Let goed op hoeveel blauwe afstandsstukjes er nodig zijn.

P Preste especial atenção ao número de espaçadores azuis necessários.

G Προσέξτε ιδιαίτερα τον αριθμό των μπλε ροδελιών που χρειάζονται.

TR Tam olarak kaç tane mavi ara halka kullanmanız gerektiğine dikkat edin.

J 必要なブルースペースターの数に十分注意してください。

CHI 請注意需要的藍間隔物的數目。

IL שים לב למספר טבעות המילוי הכחולות הדרושות.

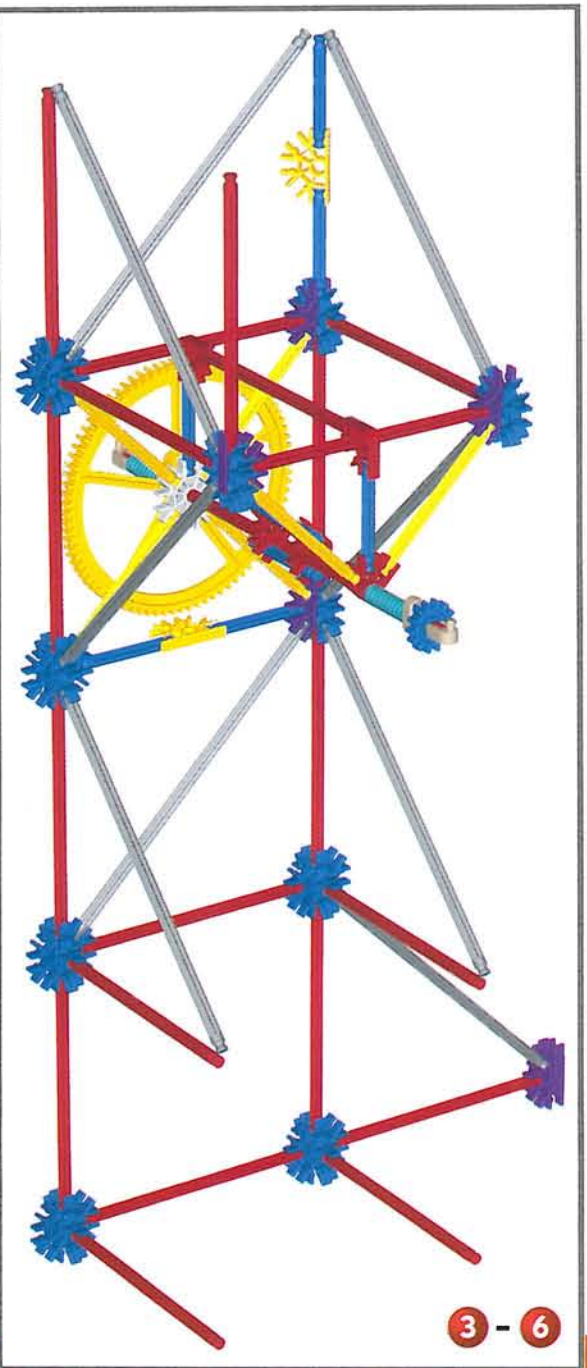
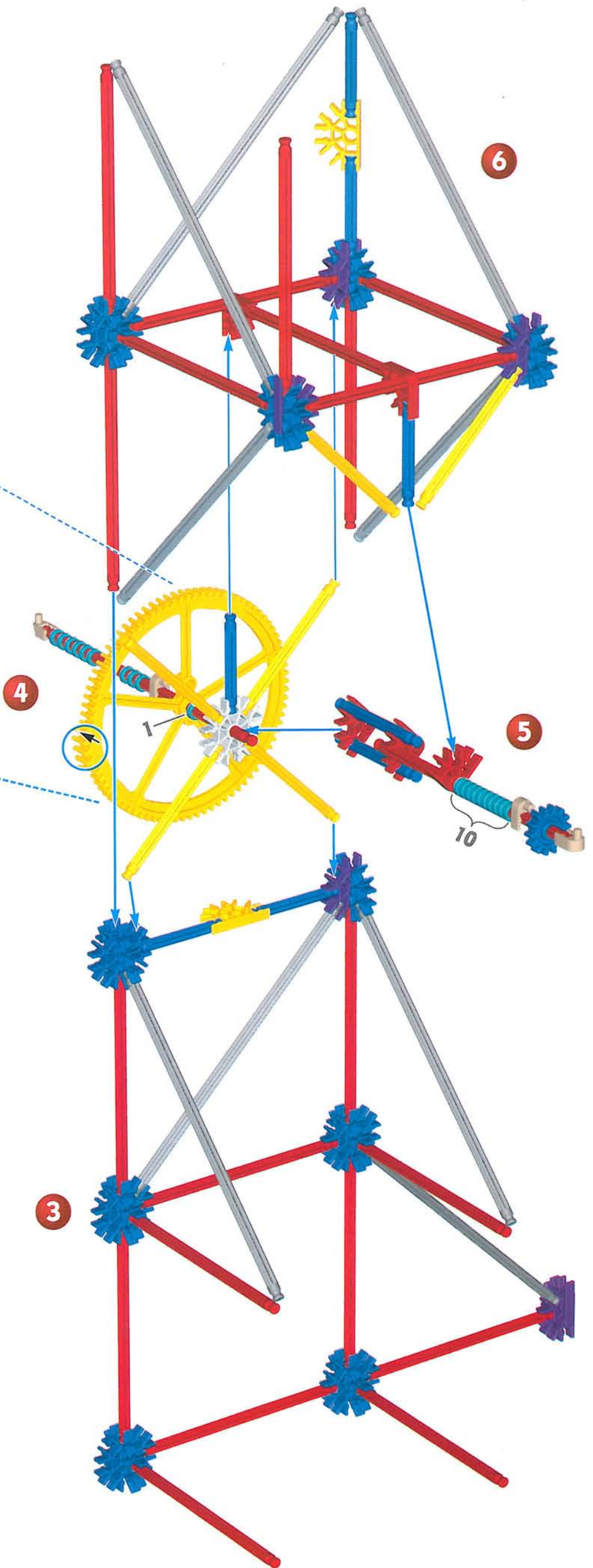
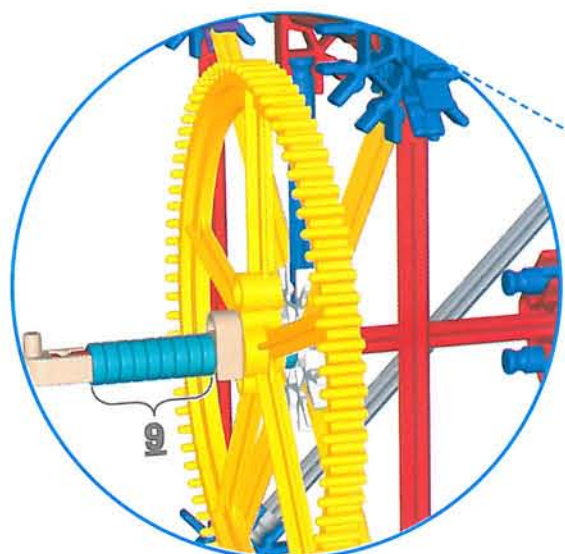
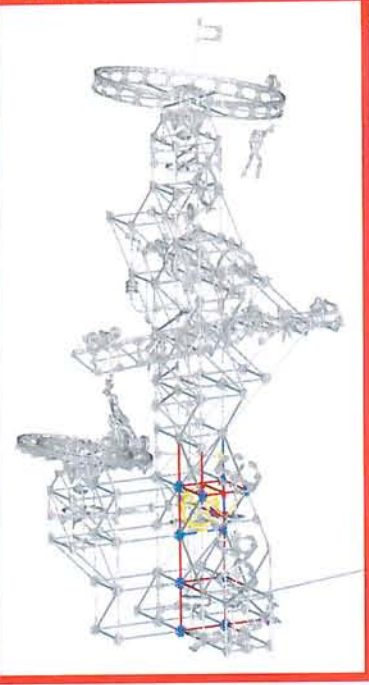

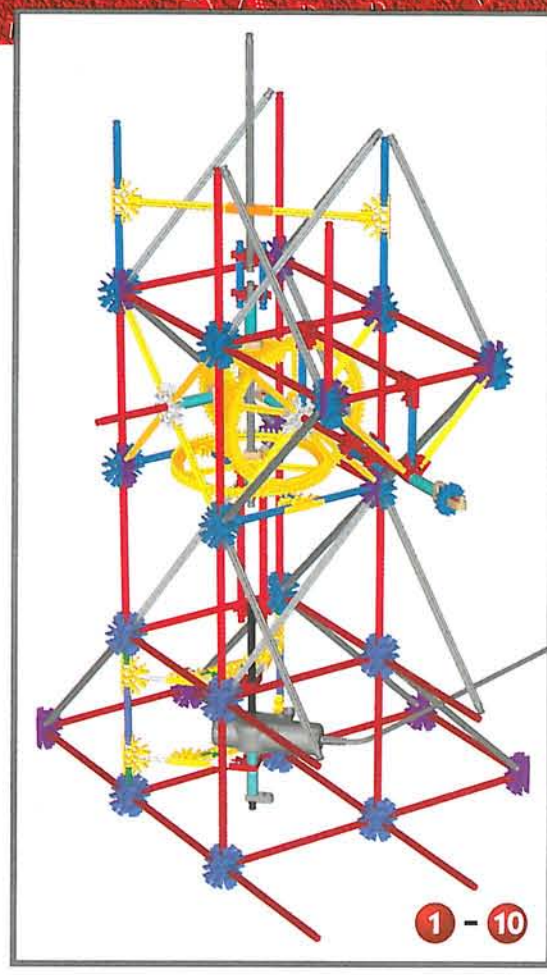
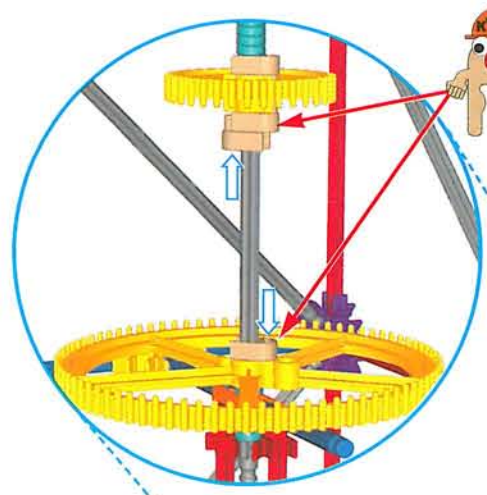

10

9

7

8

1 - 2

3 - 6

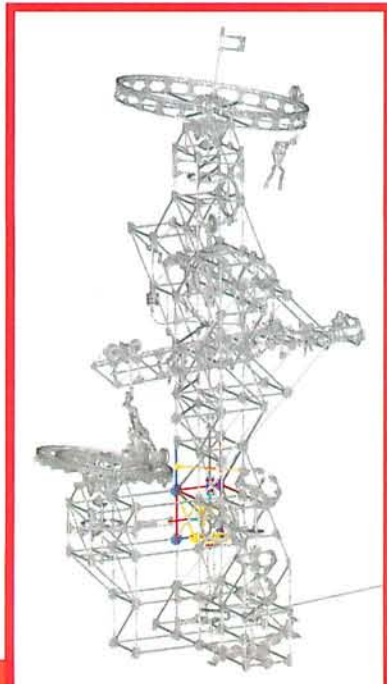

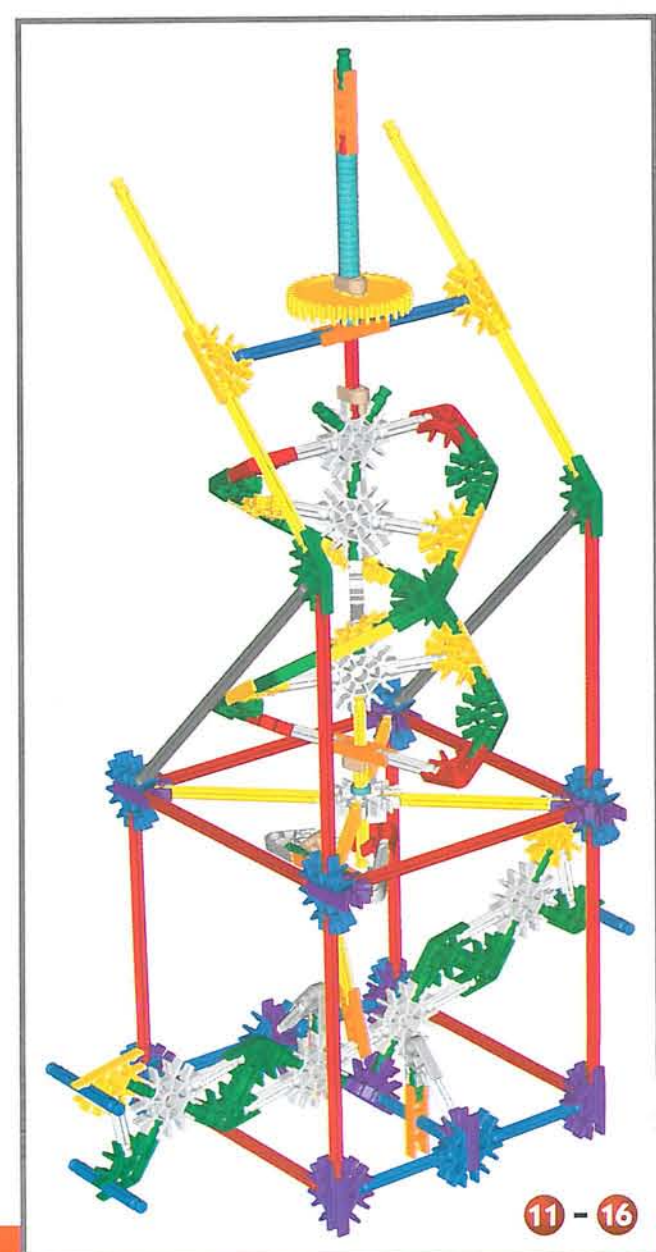
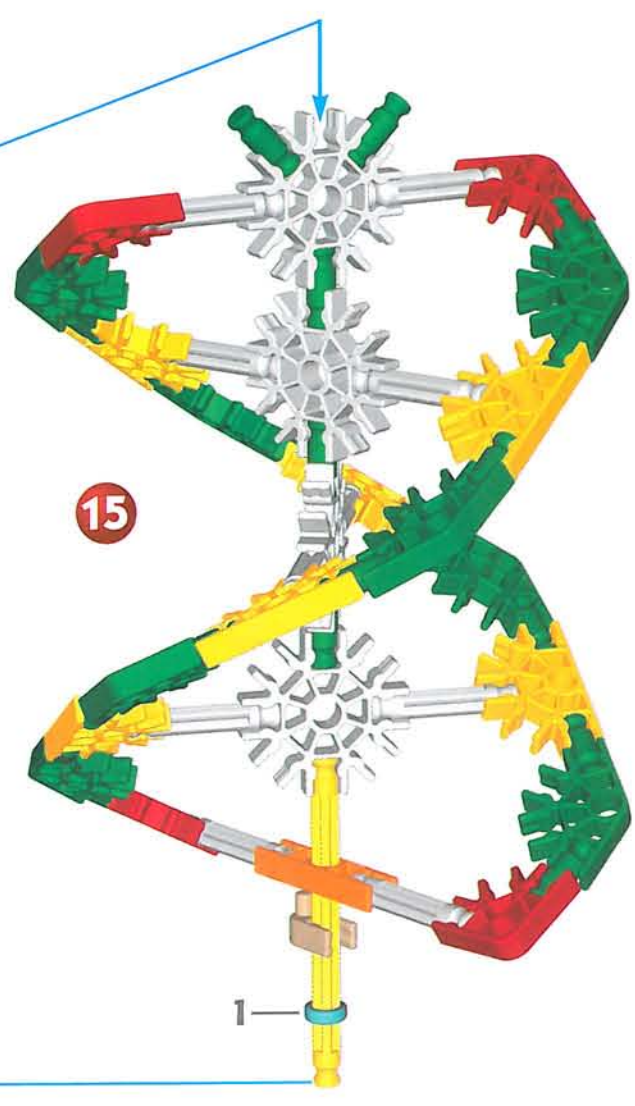
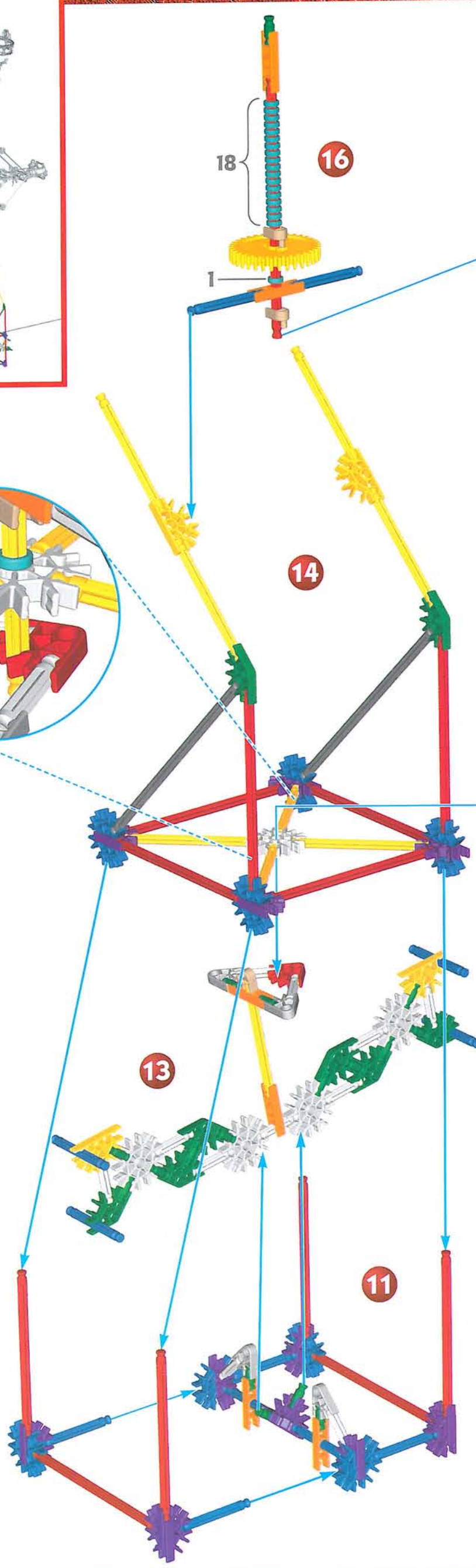
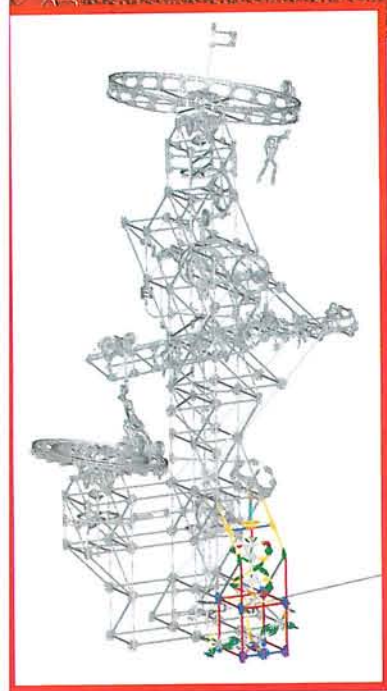

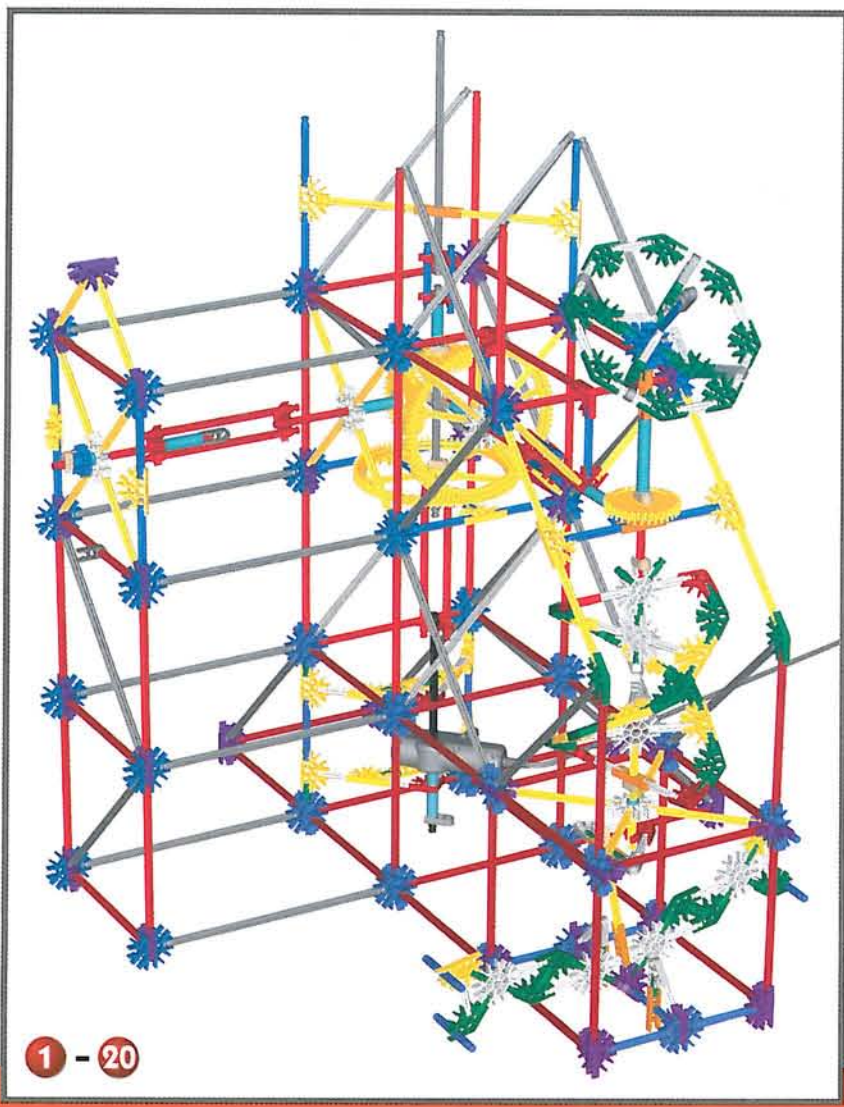
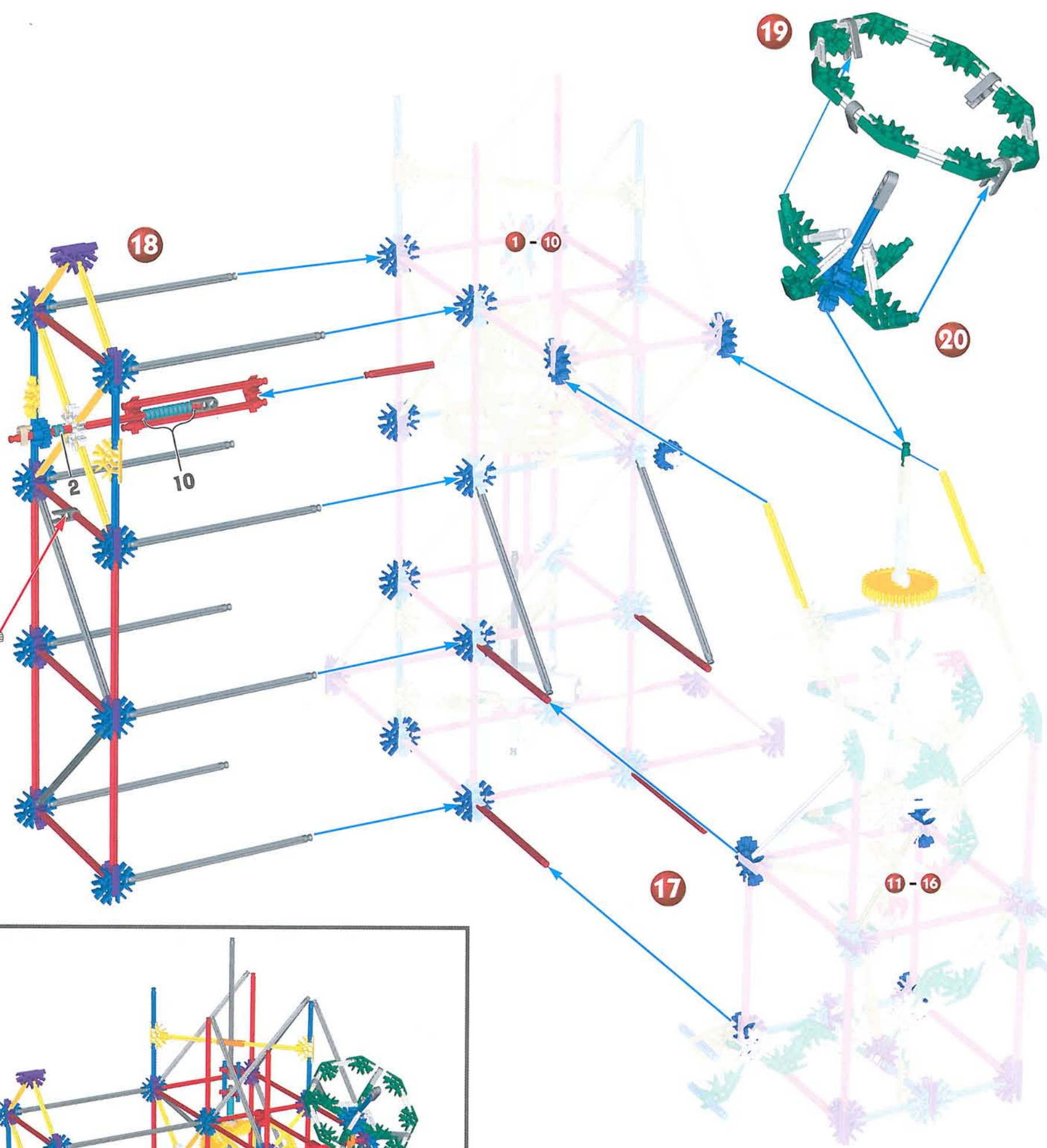

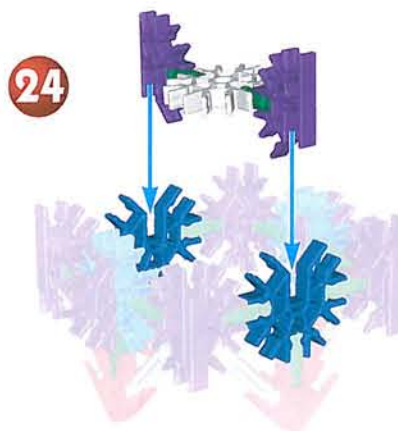
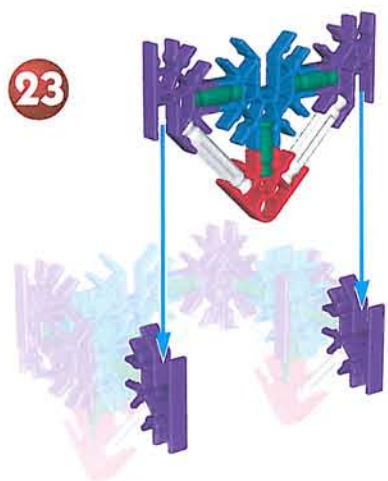
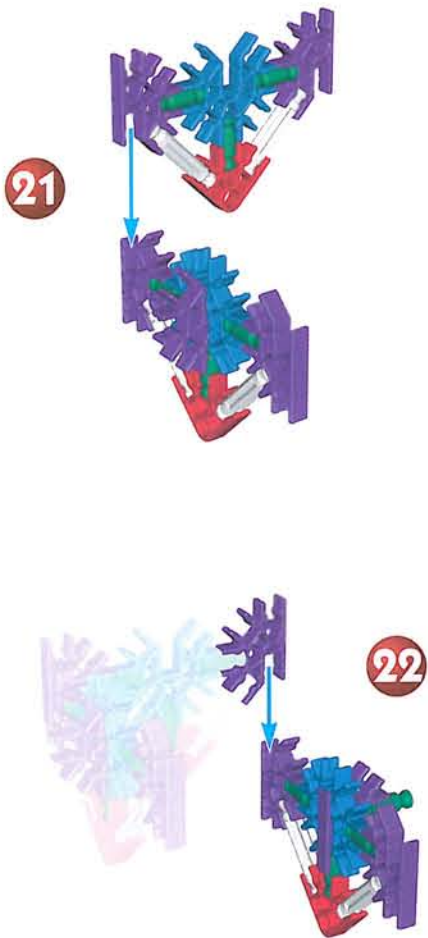
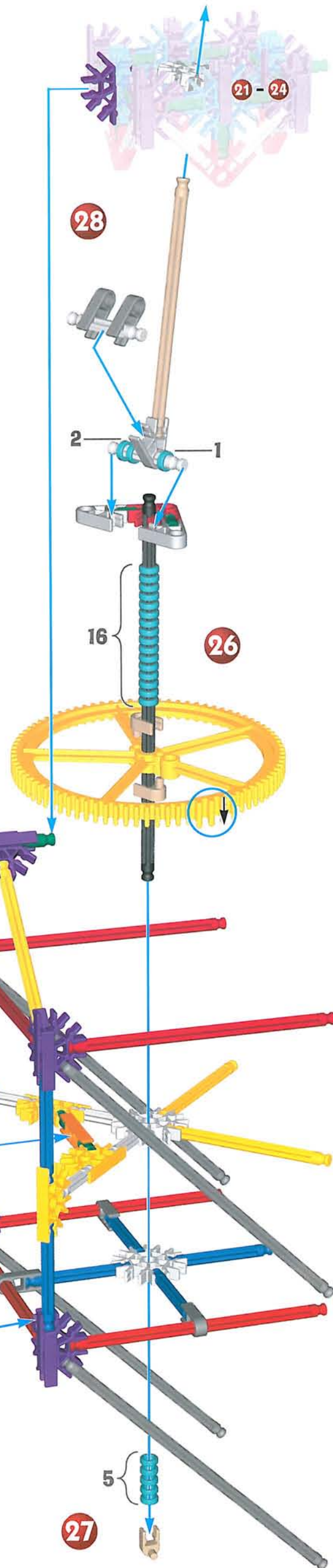
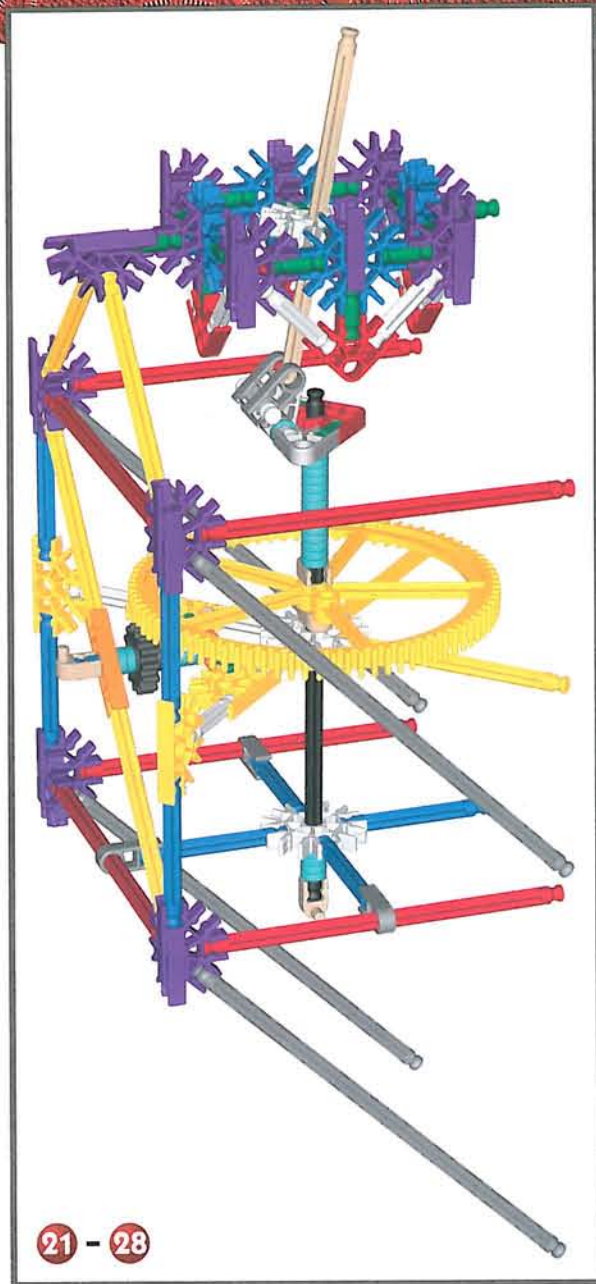
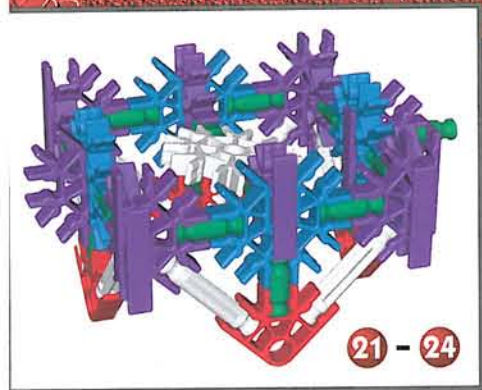

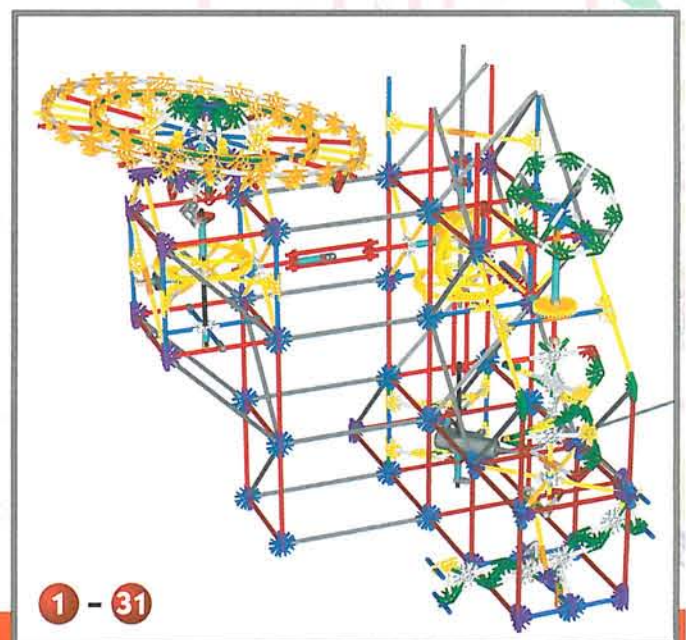
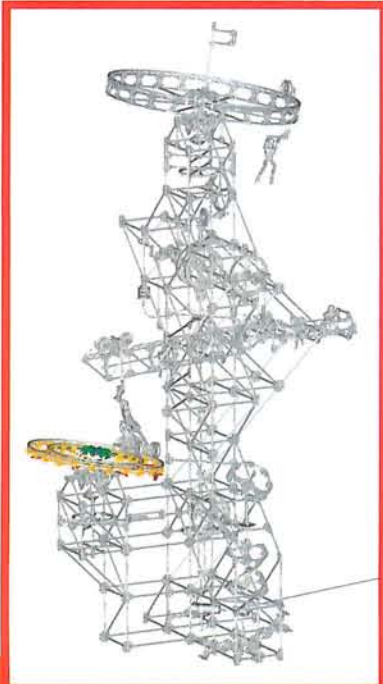
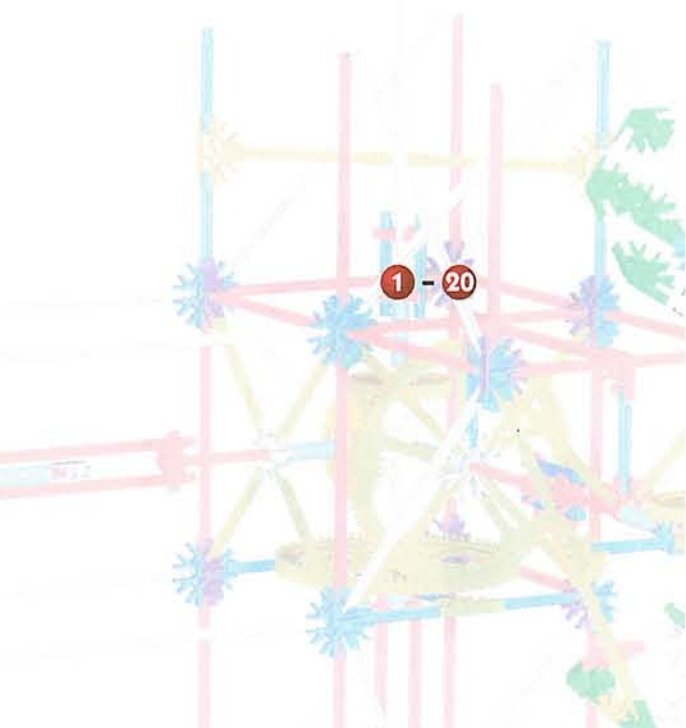
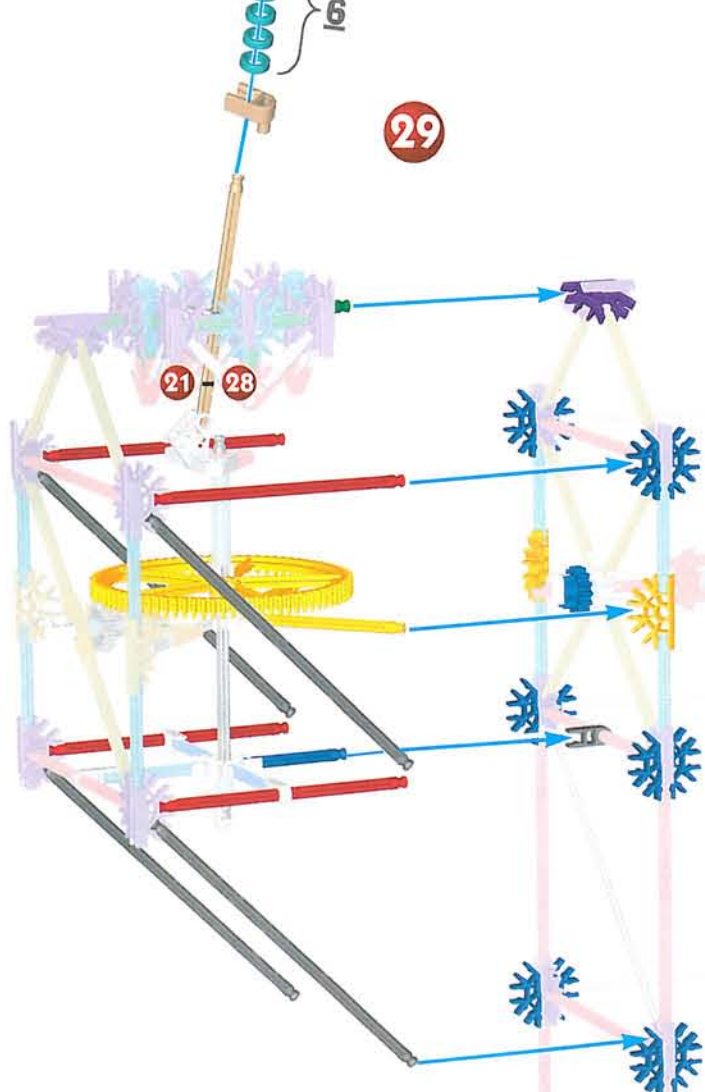
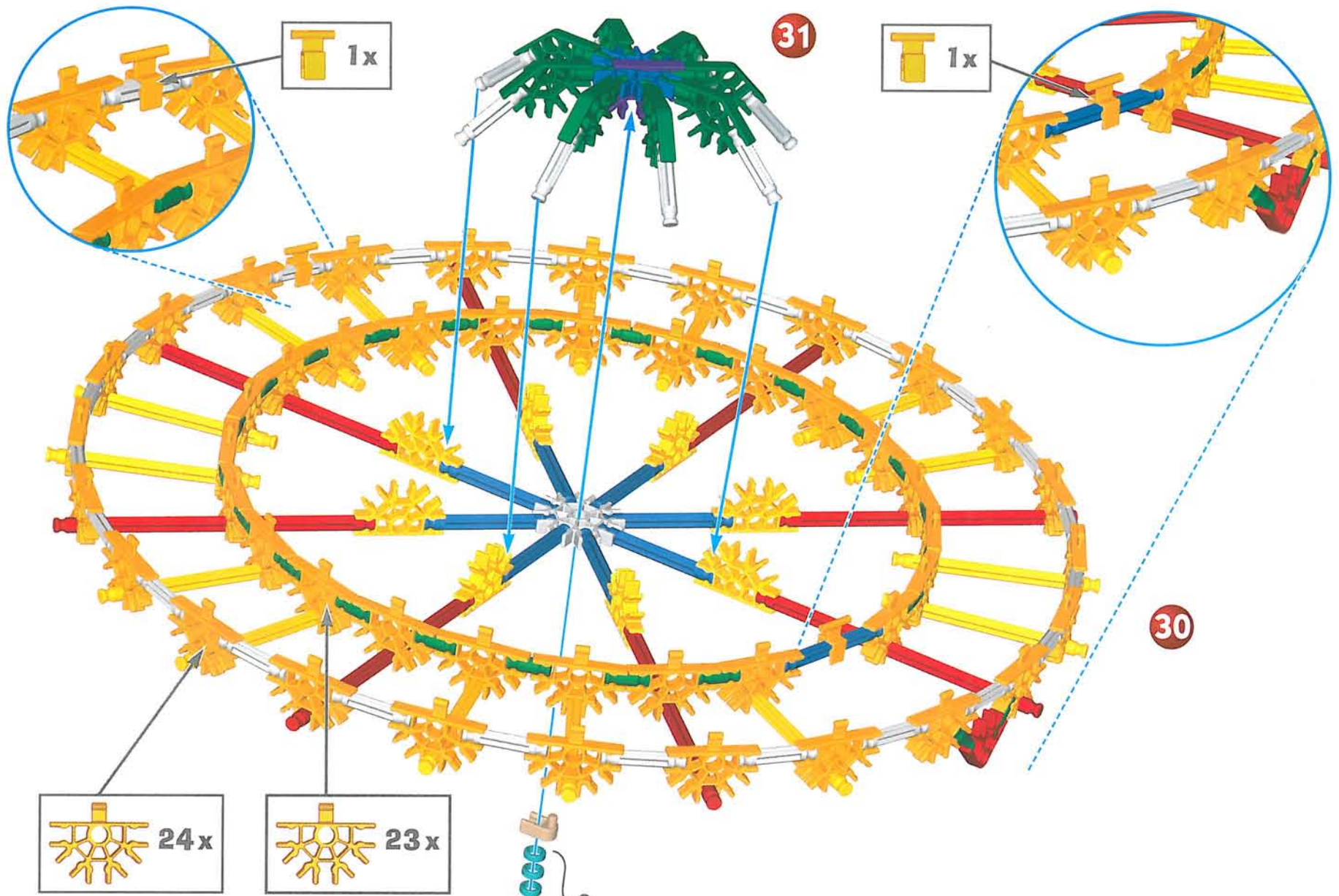

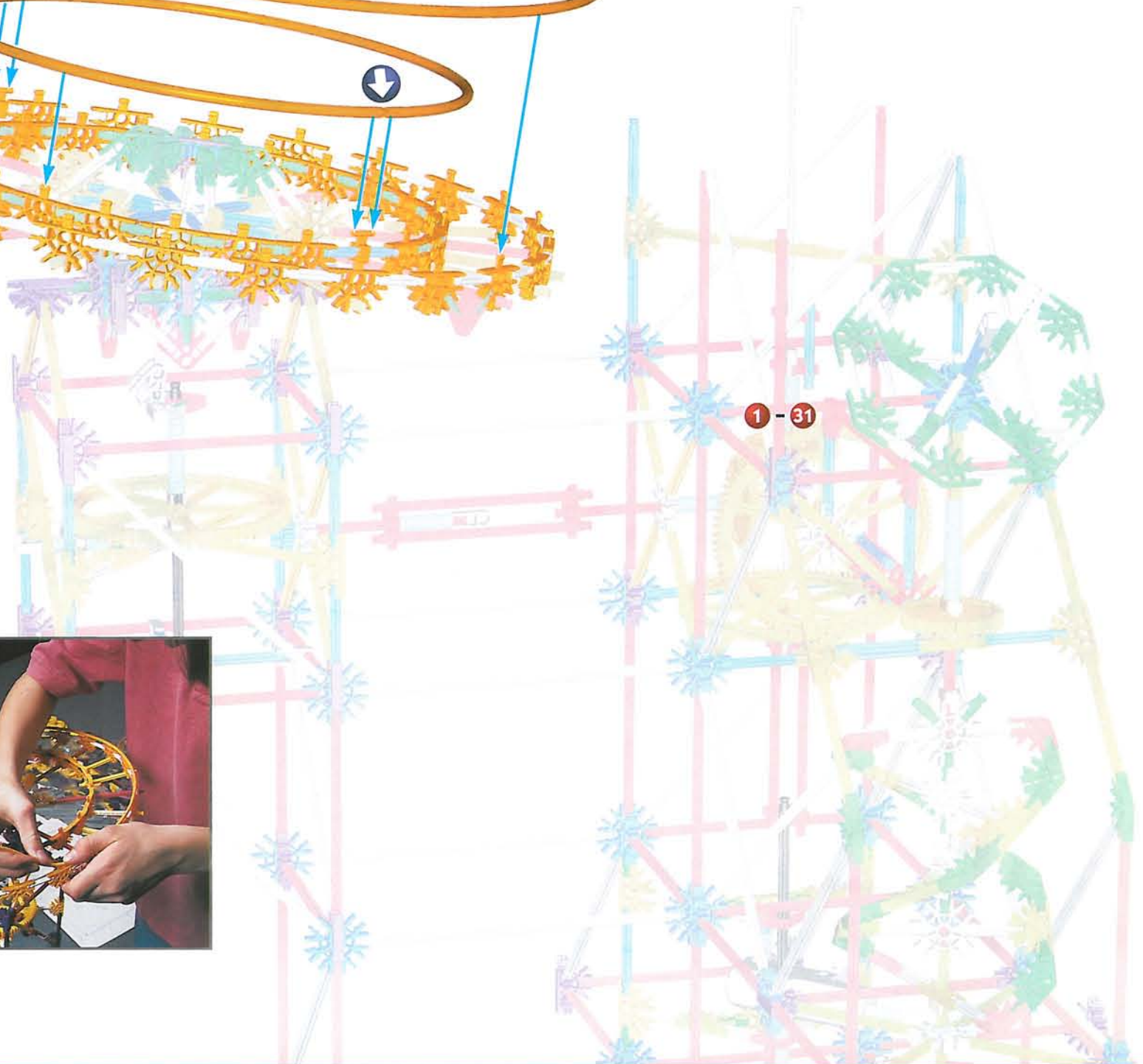
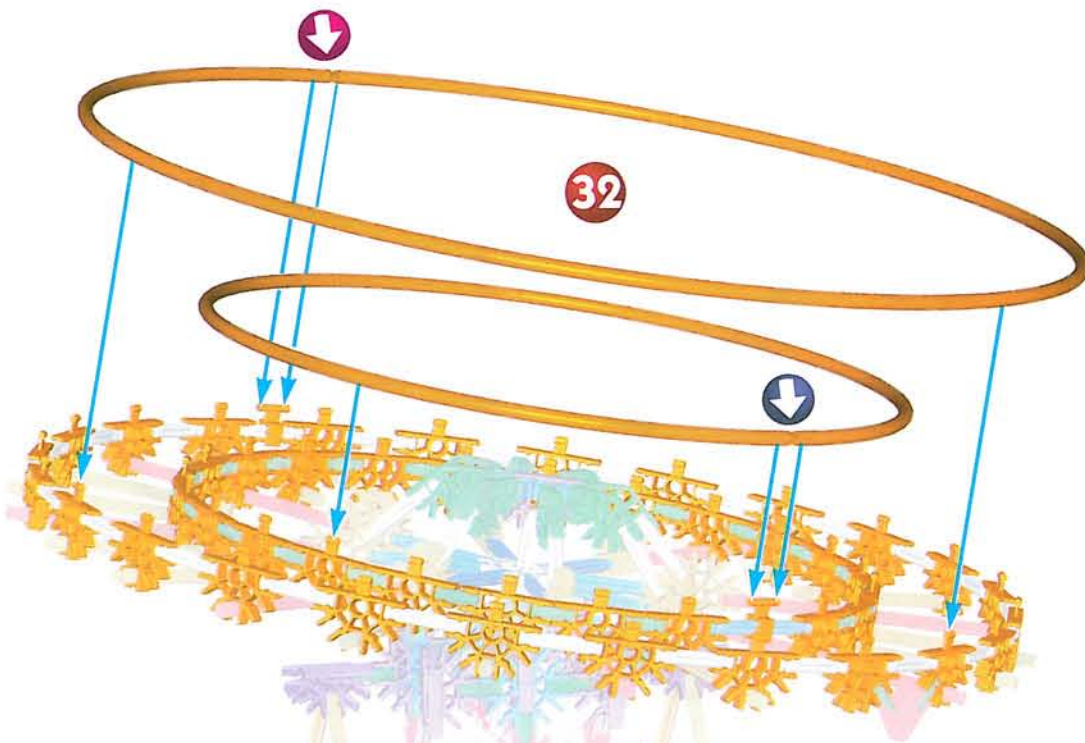
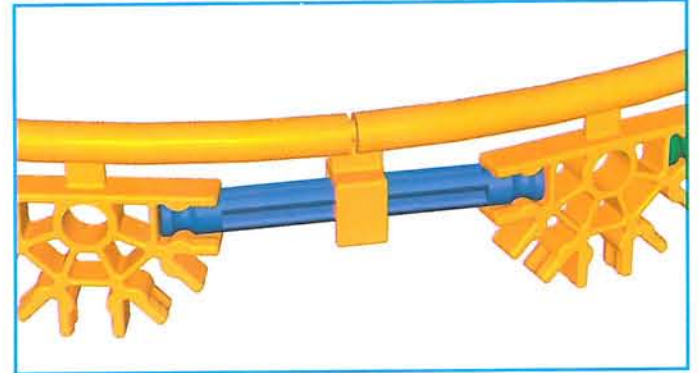
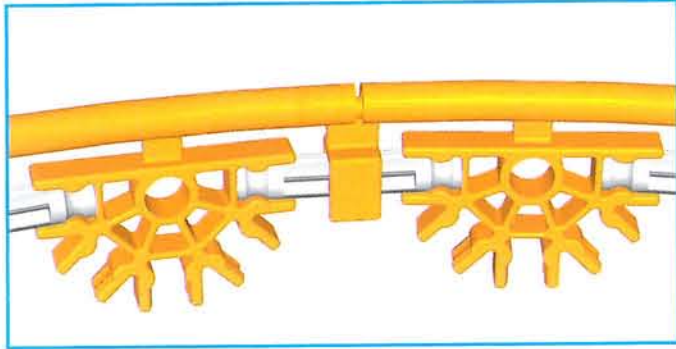
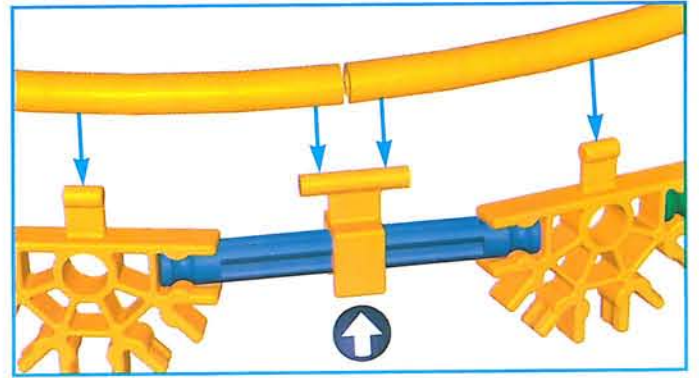
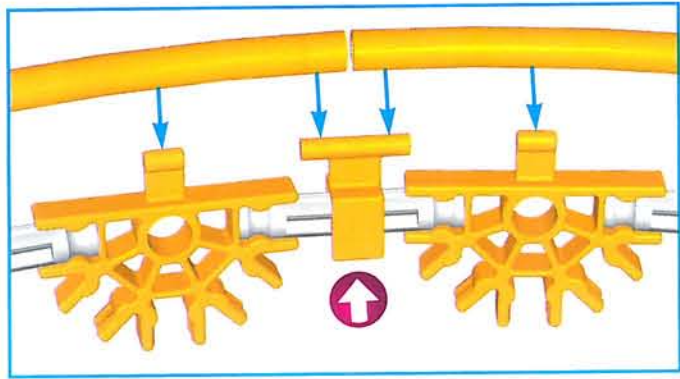

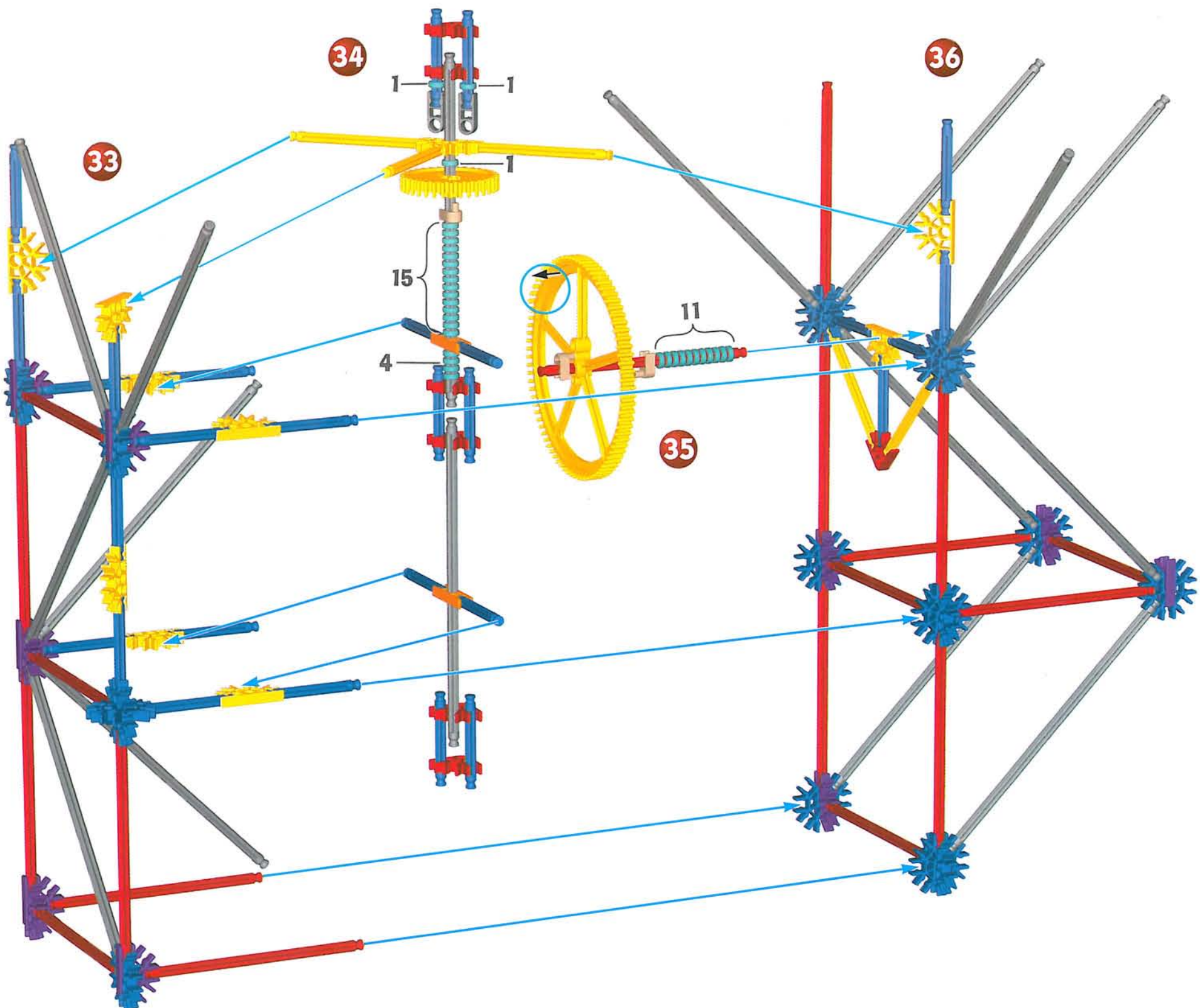
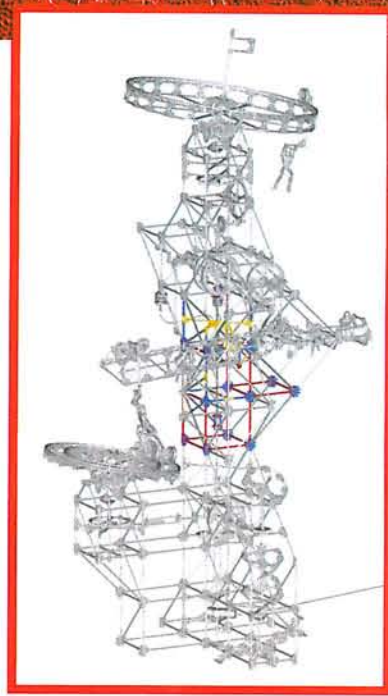
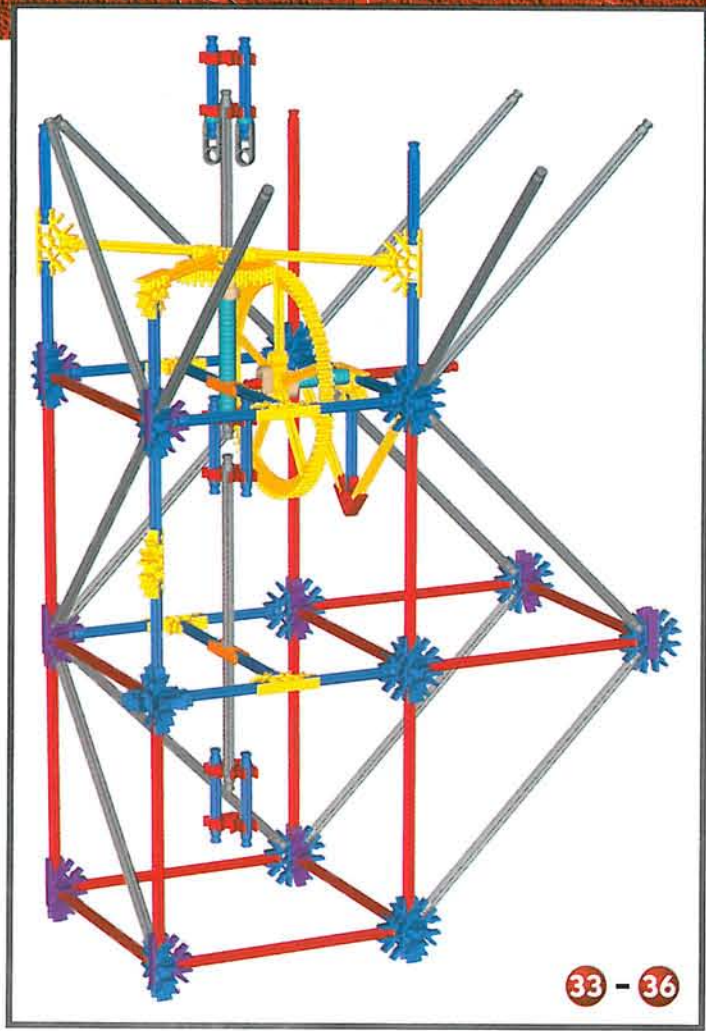

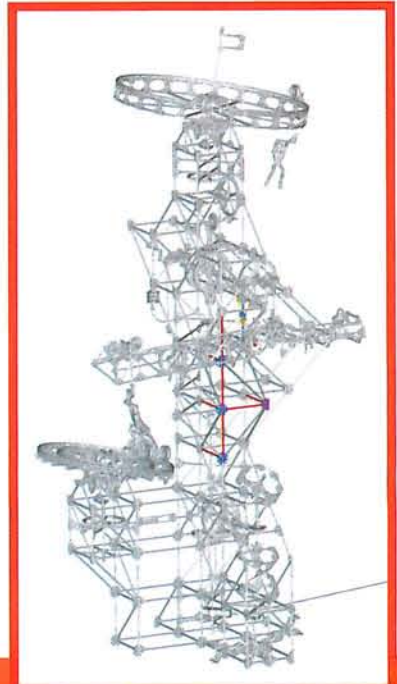
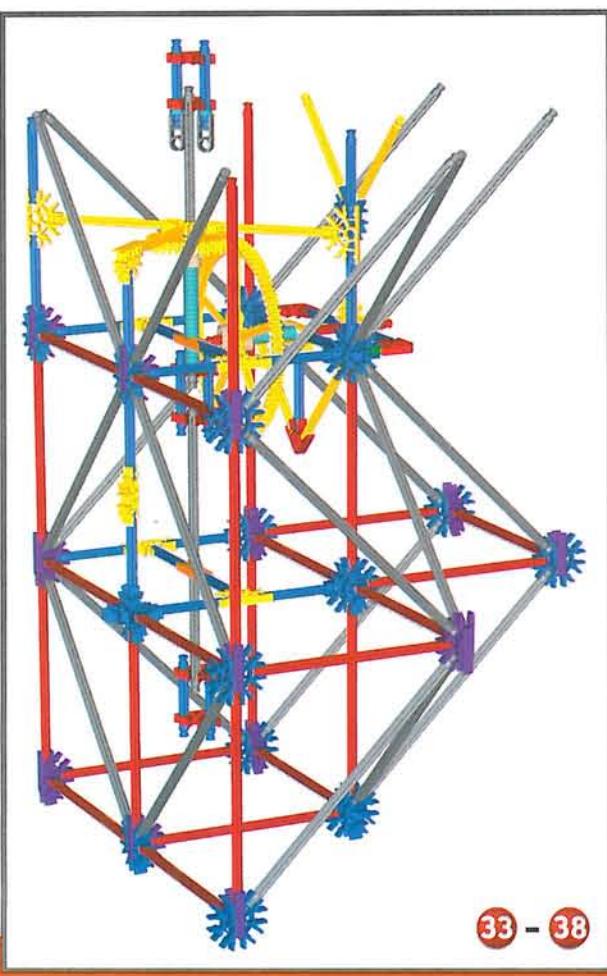
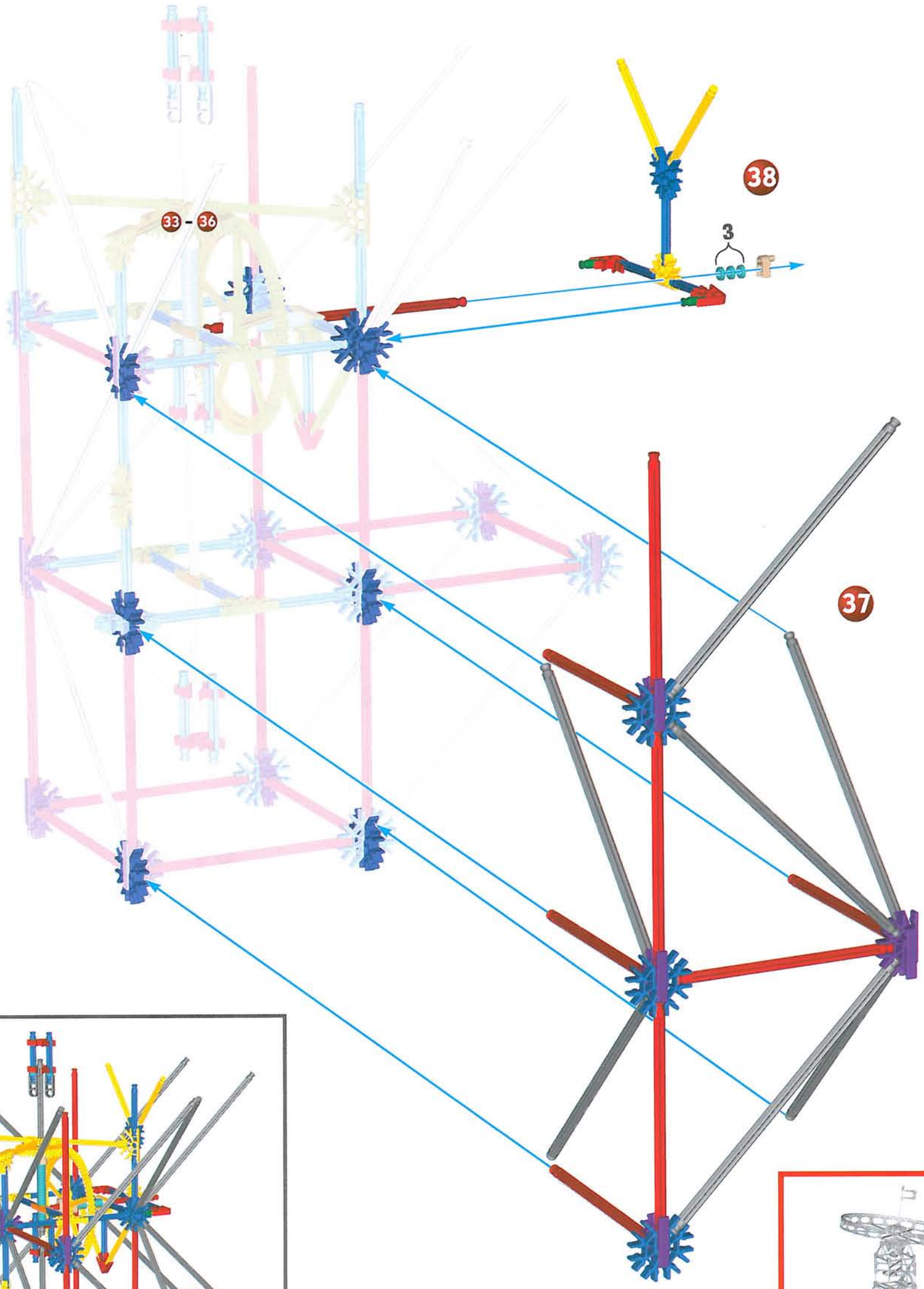

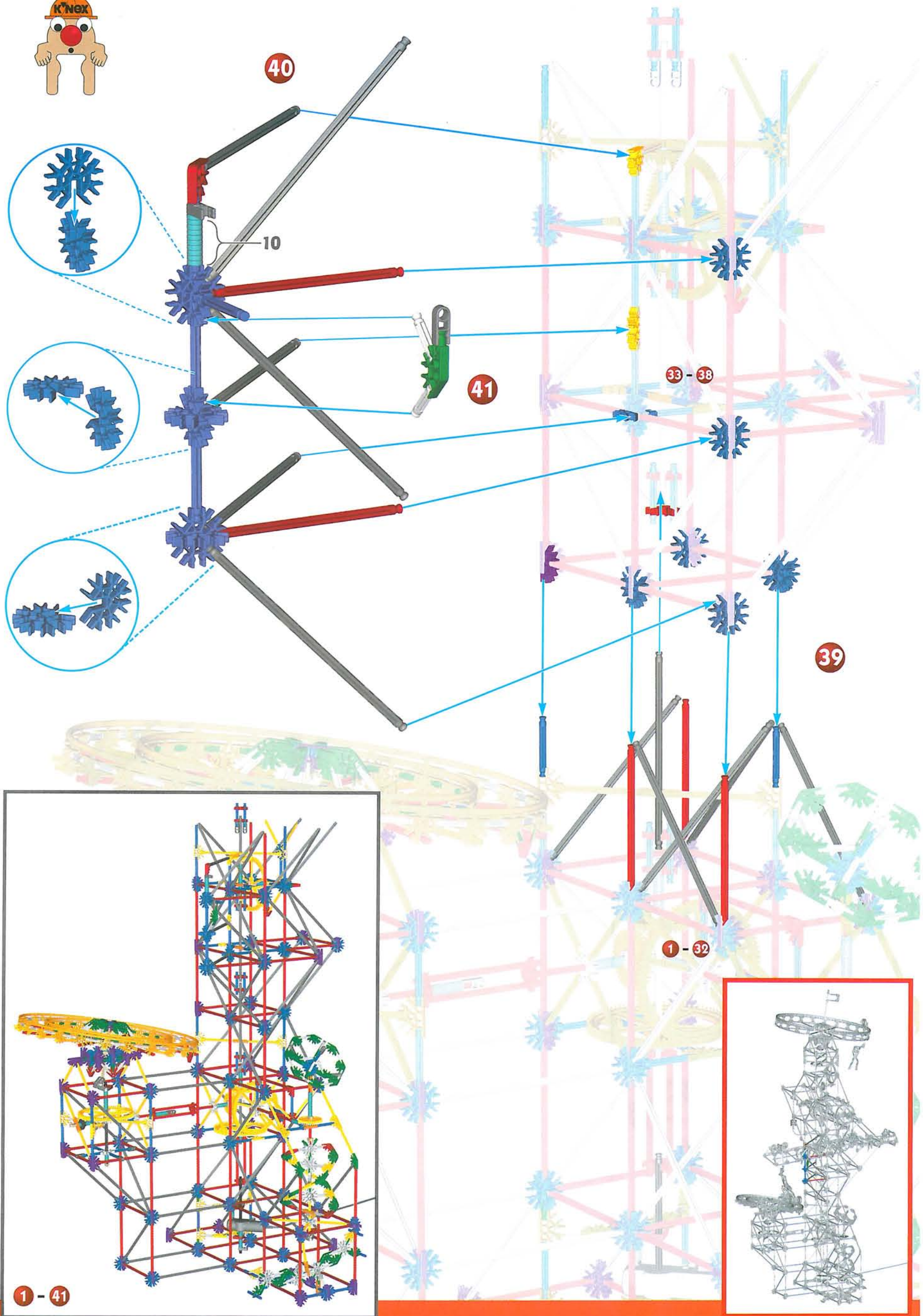

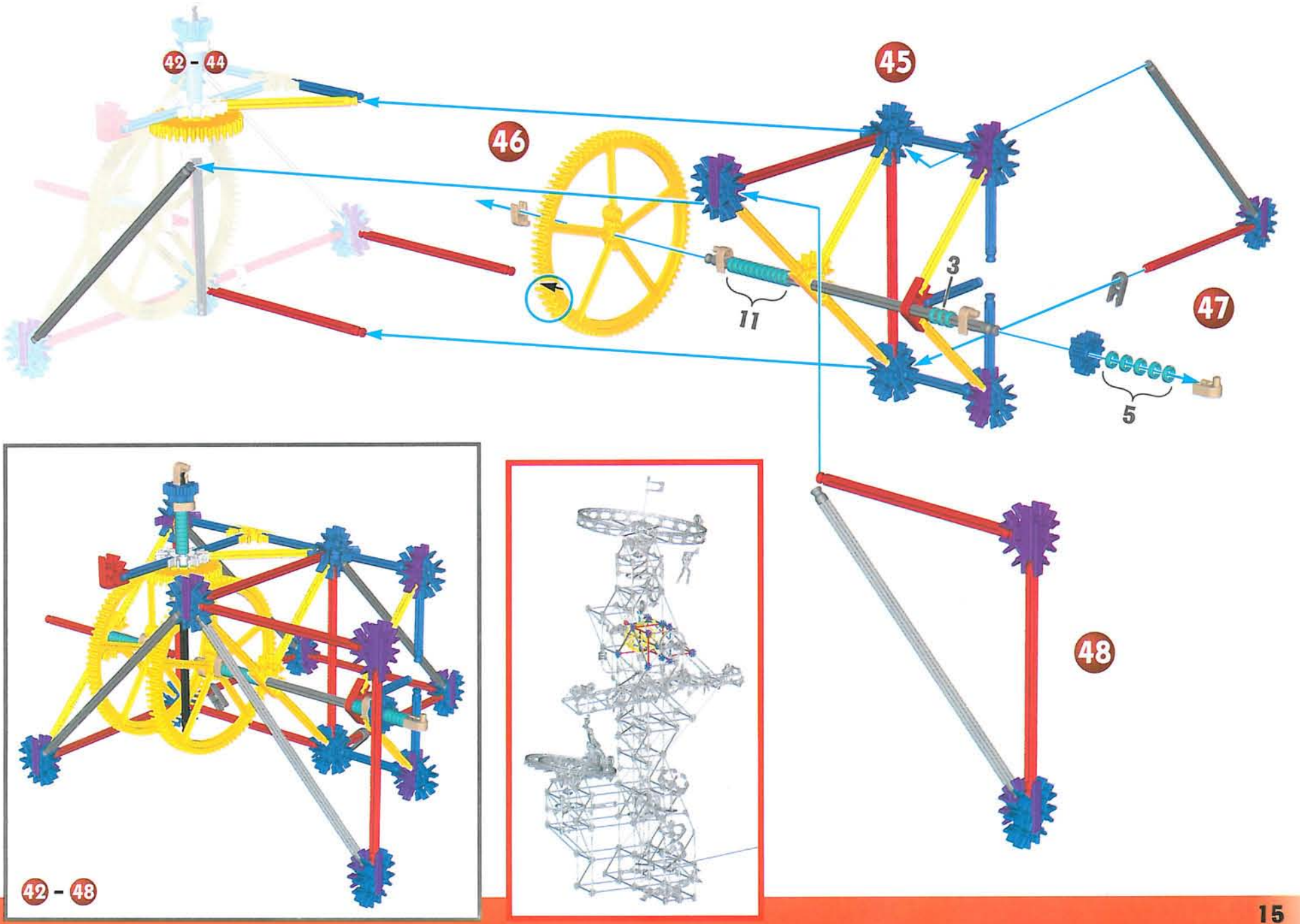
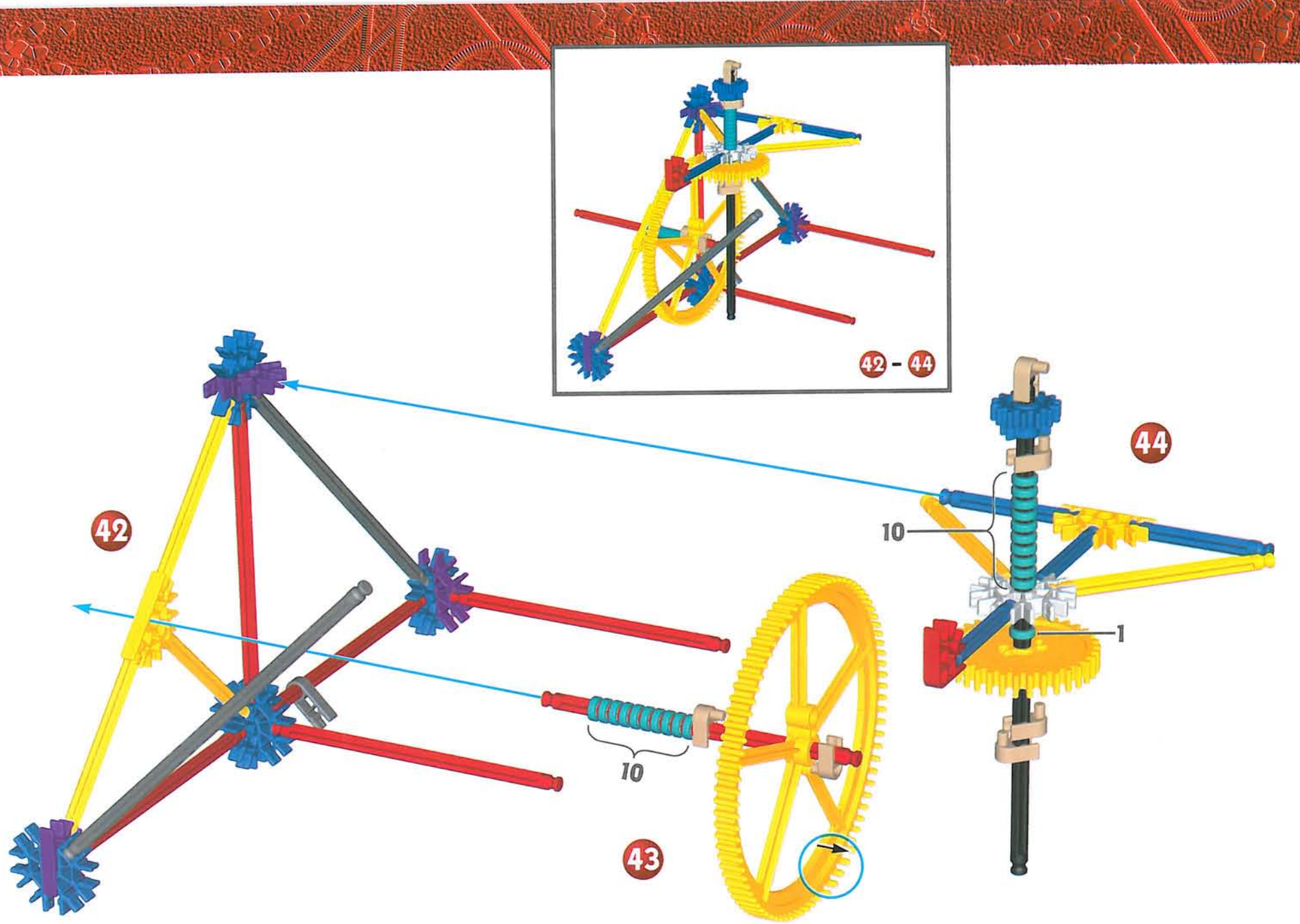

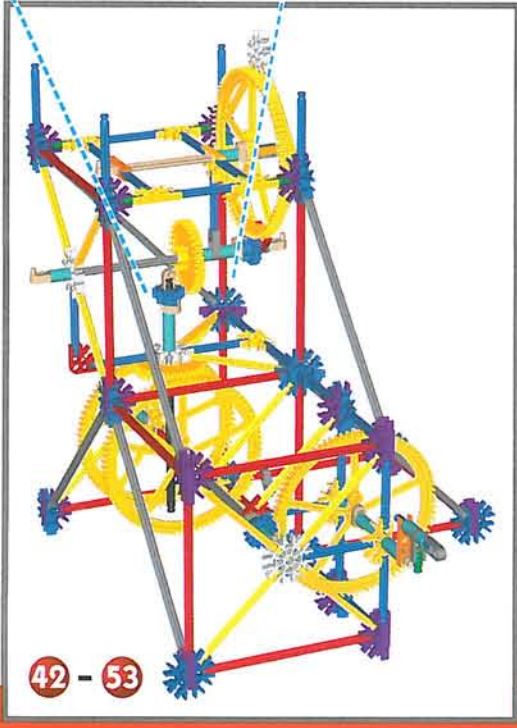
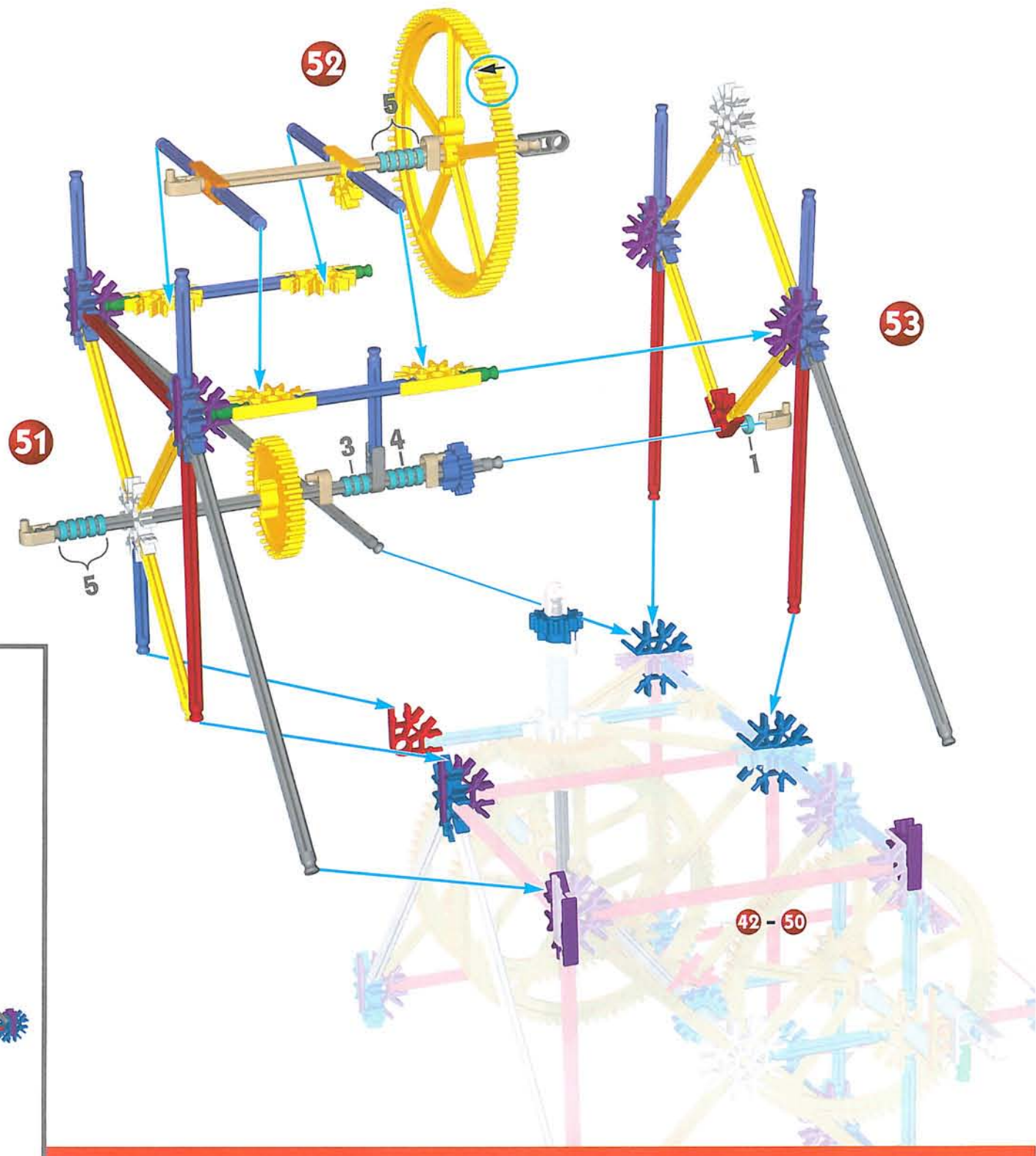
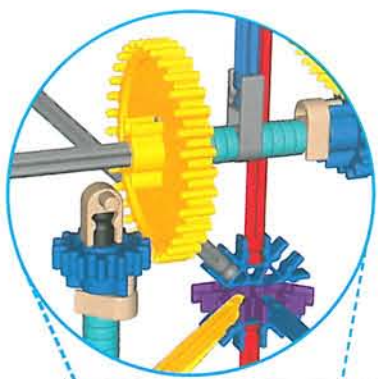
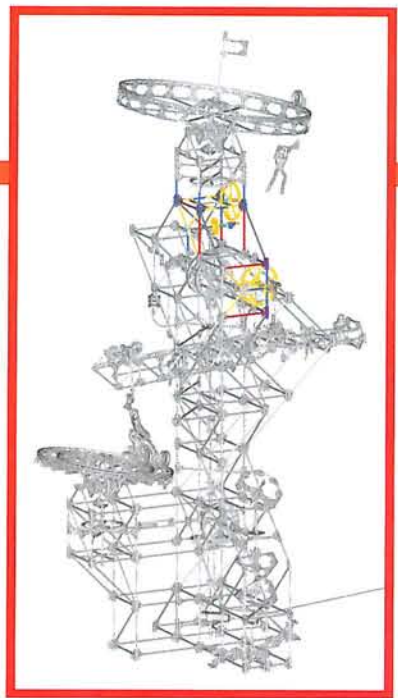
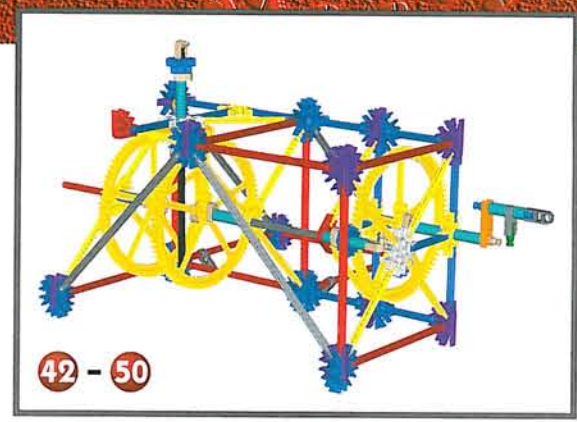
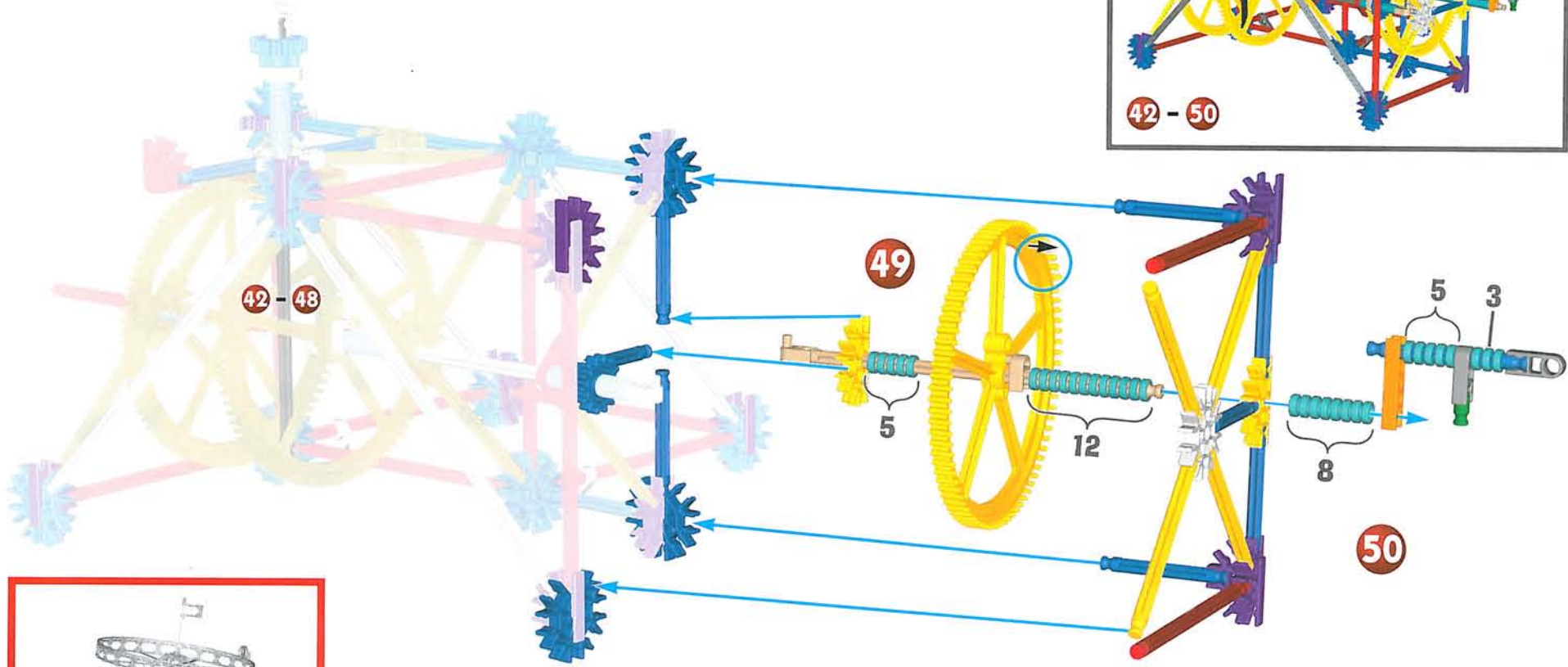

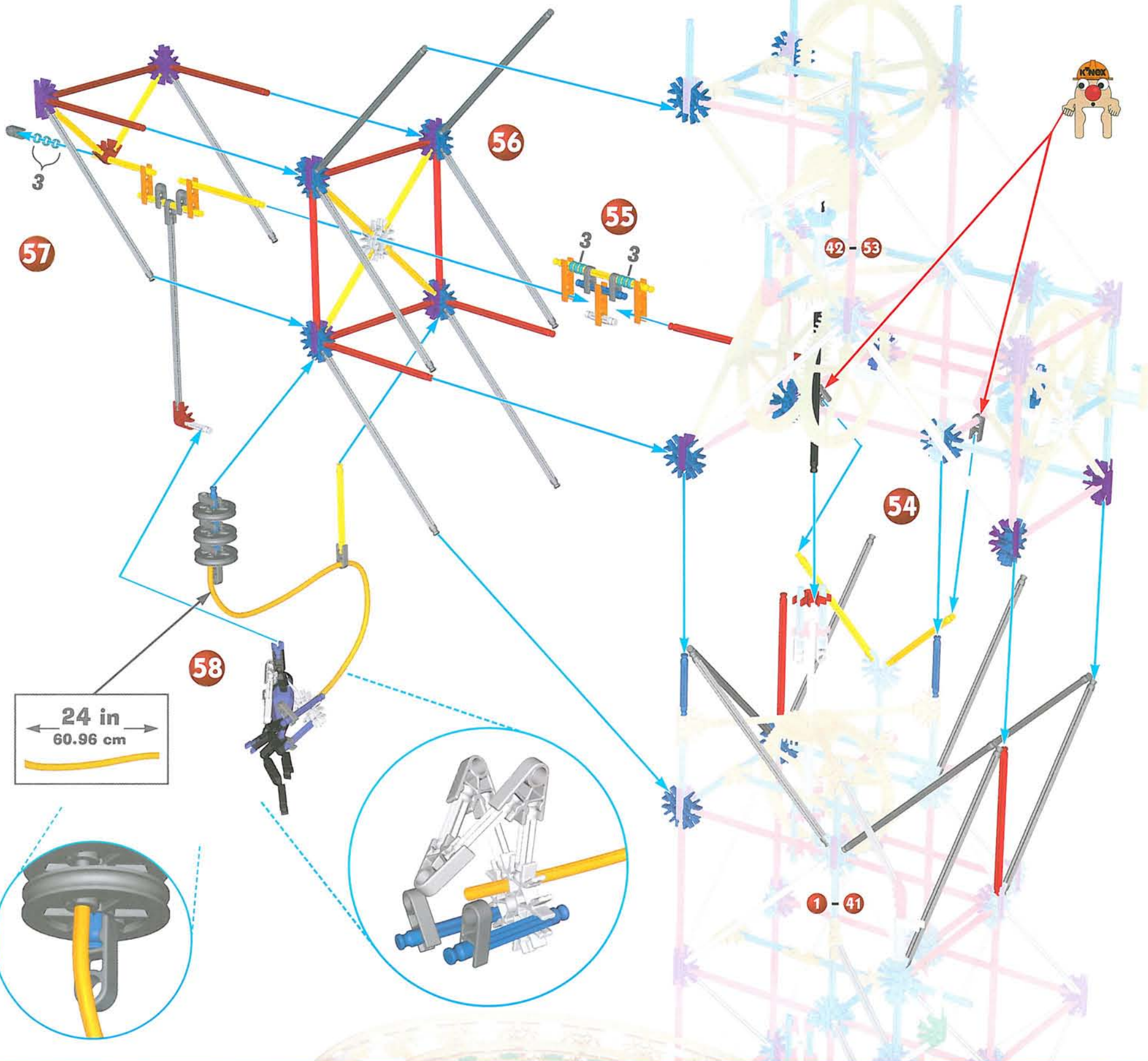
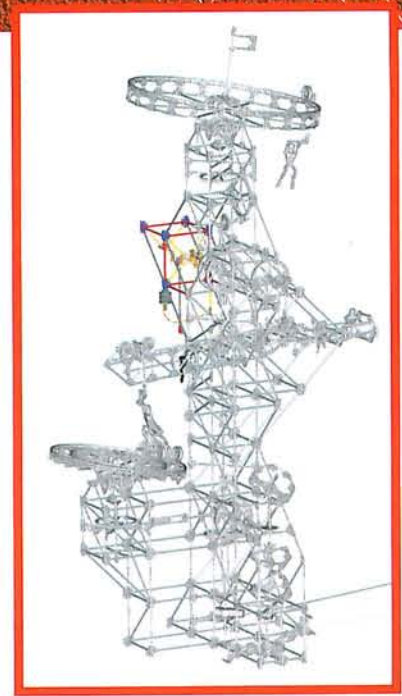
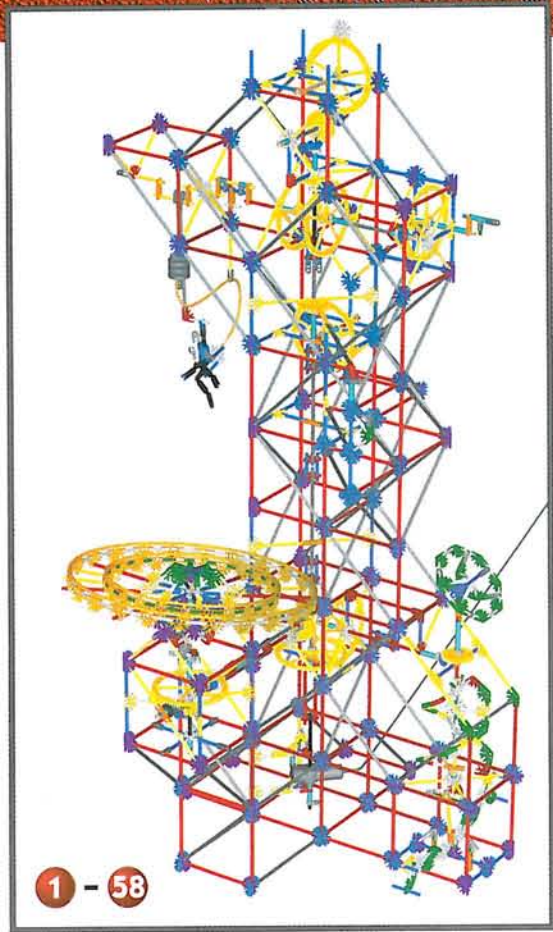

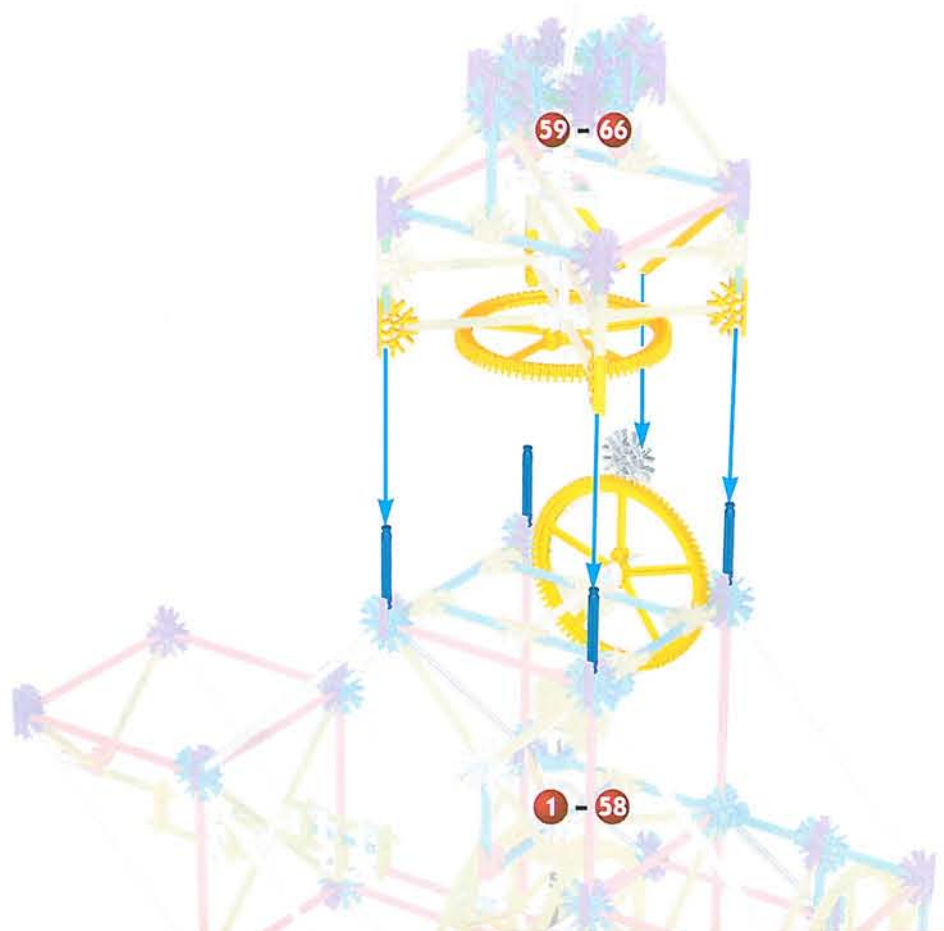
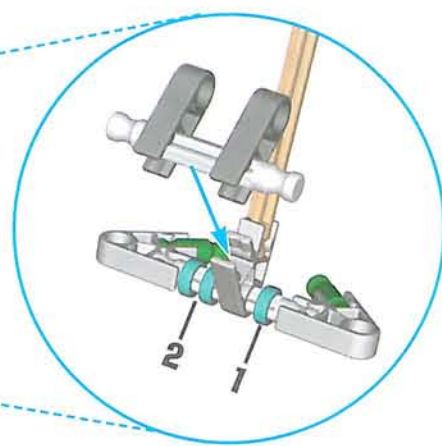
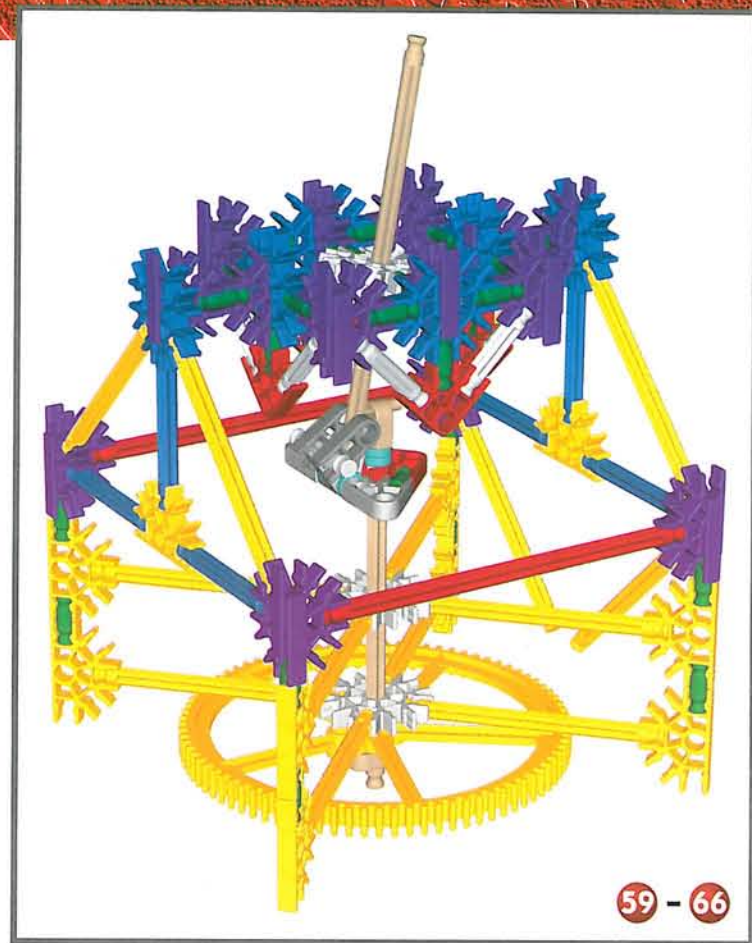
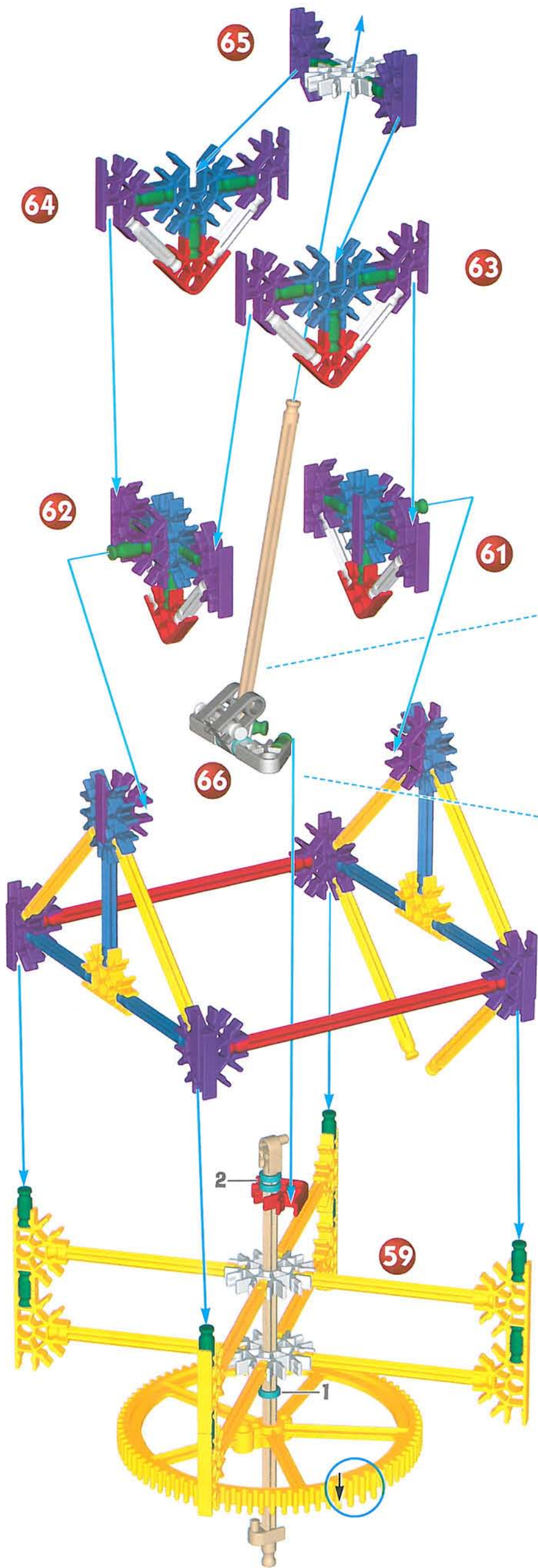

- USA (GB)** Attach tubing before connecting to model.
- F** Fixez le tube sur ses connecteurs avant de l'assembler au modèle.
- I** Fissare i binari flessibili prima di collegarli al modello.
- D** Befestigen Sie die Rollschienen an den Verbindungsstücken, bevor Sie sie am Modell anbringen.
- E** Acoplar los tubos antes de conectarlos al modelo.
- S** Fäst rören före anslutning till modellen.
- DK** Sæt rørene sammen, inden de sættes på modellen.
- N** Sett sammen rørene før du fester dem til modellen.
- SF** Yhdistä putki ennen kuin liität sen malliin.
- NL** De slangetjes aan elkaar bevestigen alvorens ze op het model aan te sluiten.
- P** Encaixe os tubos antes de os colocar no modelo.
- G** Προσαρμόστε τη γραμμική τροχιά πριν την συνδέσετε στο μοντέλο.

- TR** Boruları modele takmadan önce birbirine geçirin.
- J** モデルにつなげる前にチューブを取り付けてください。
- CHI** 先將管子接好再連接到模型上。
- IL** חבר את הצינורות לפי החיבור לדגם.

68

67

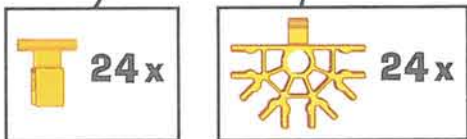

69

71

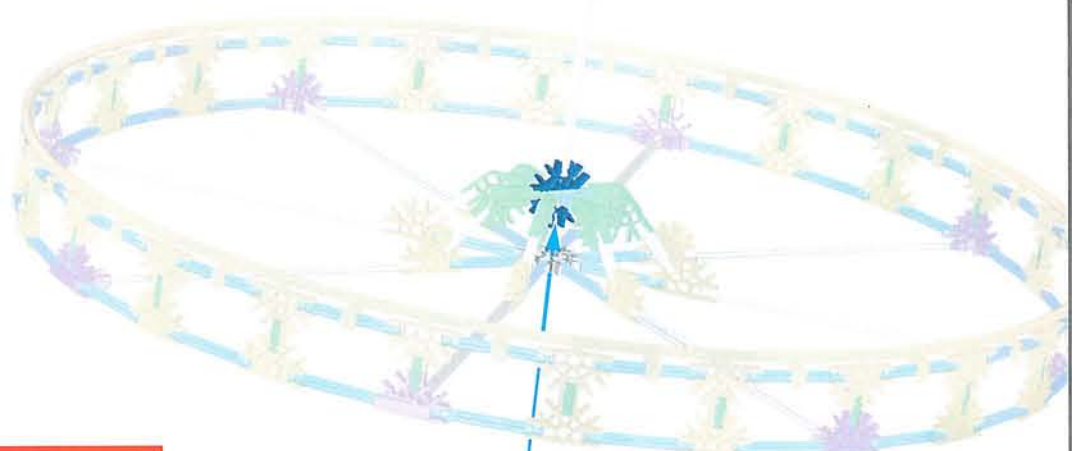
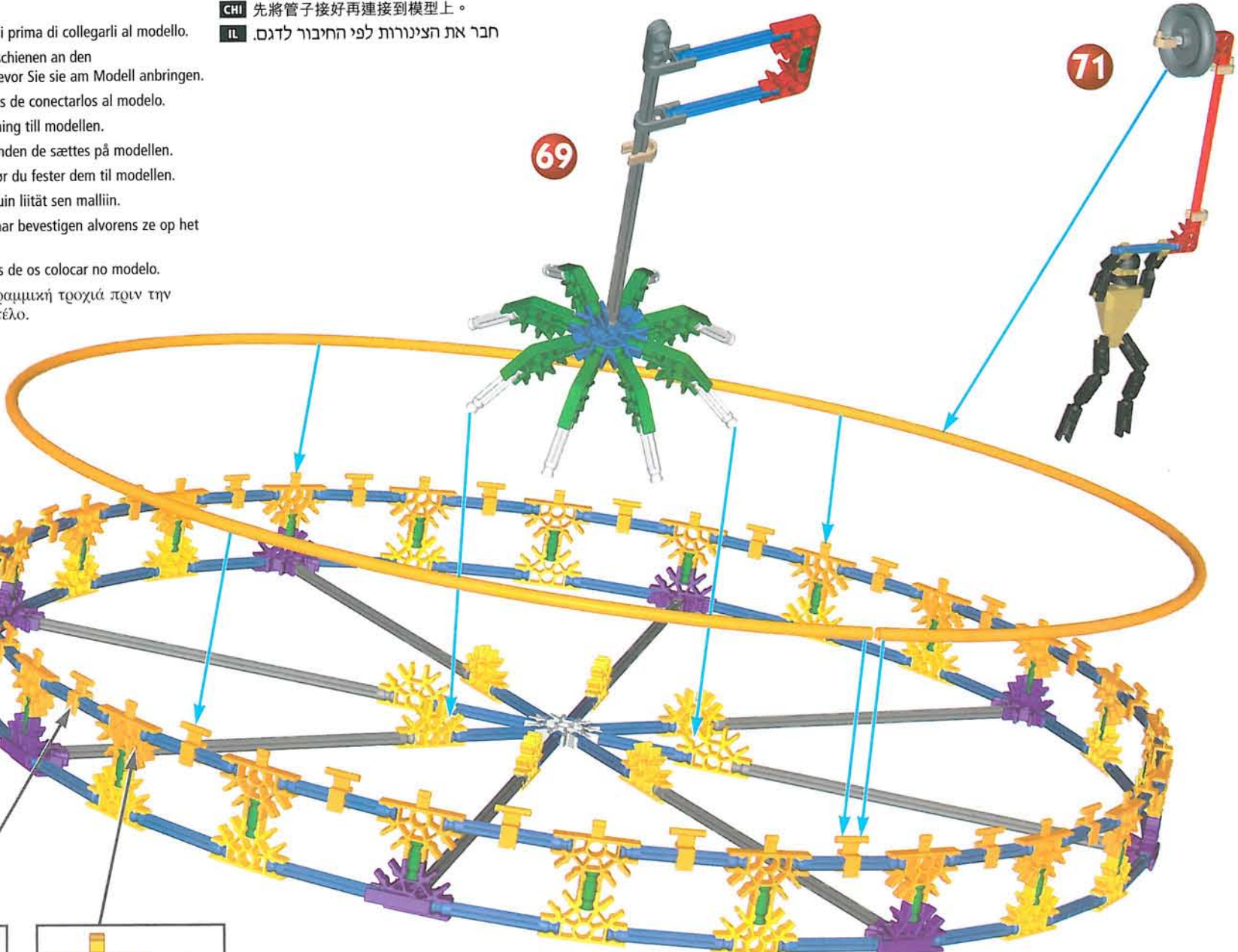

70

16

1 - 66

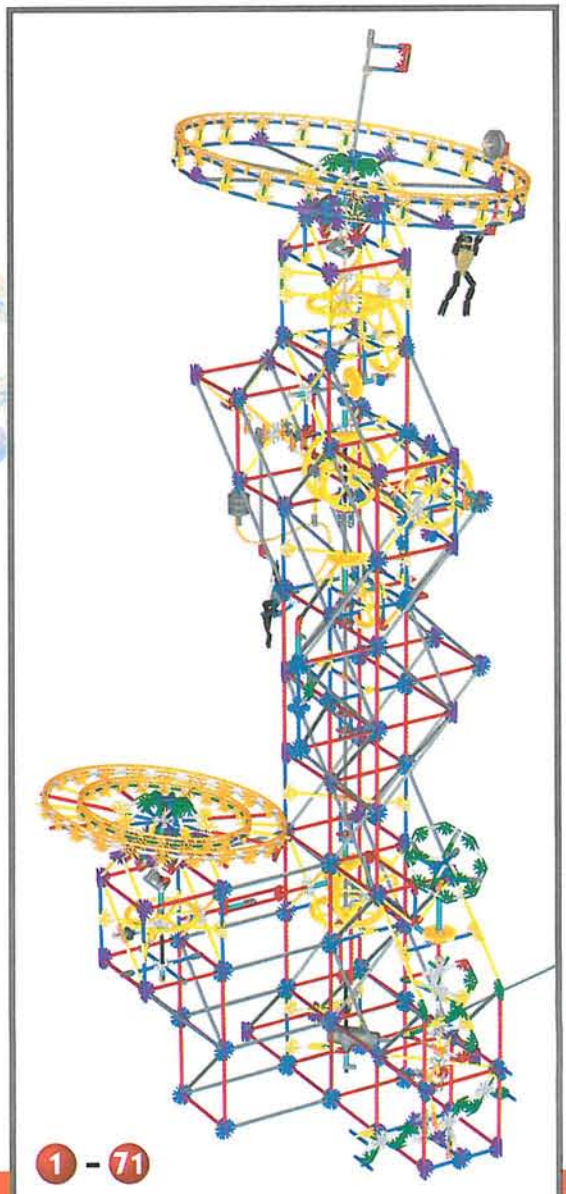

1 - 71

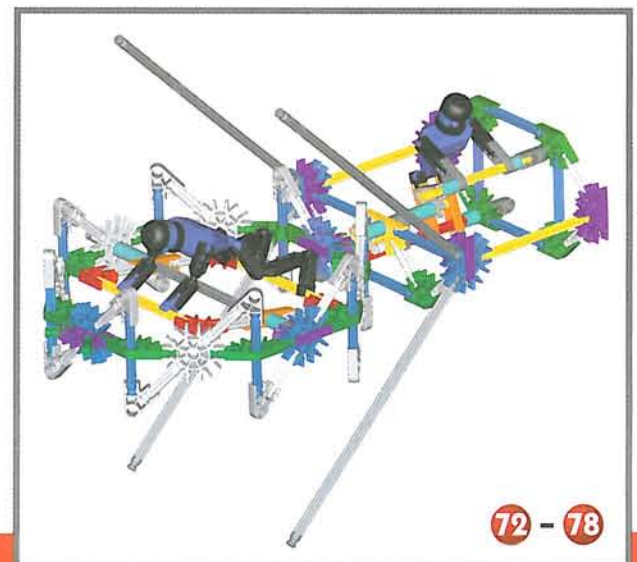
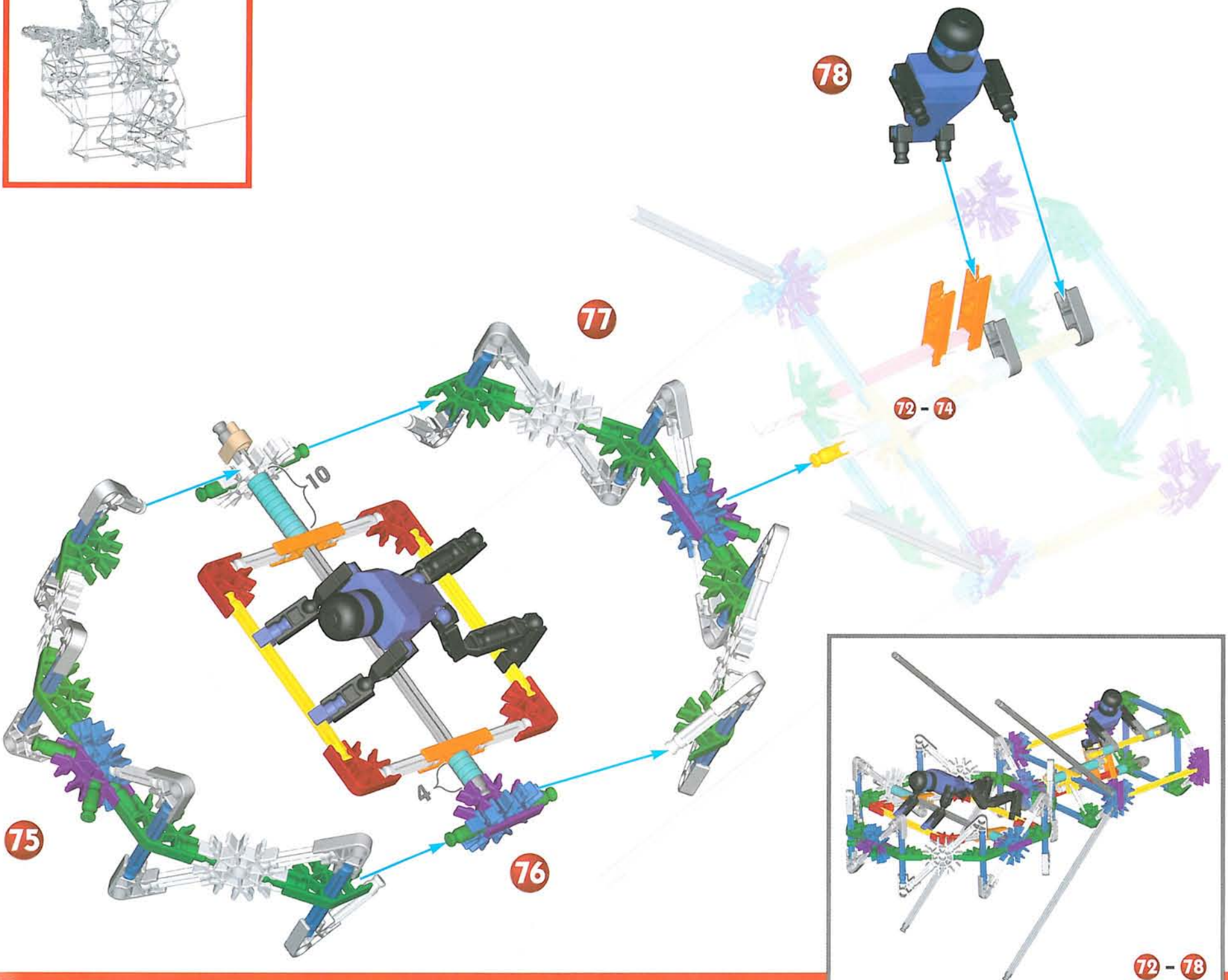
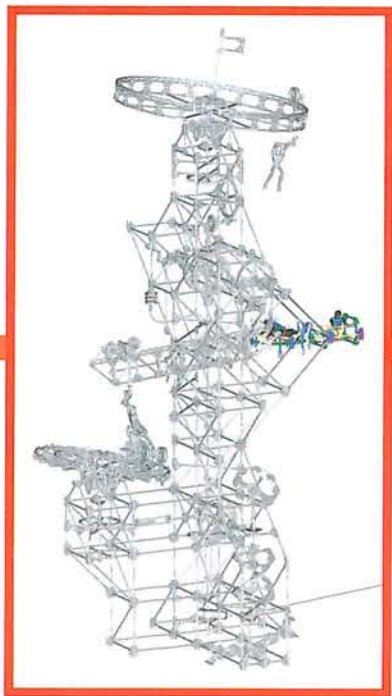
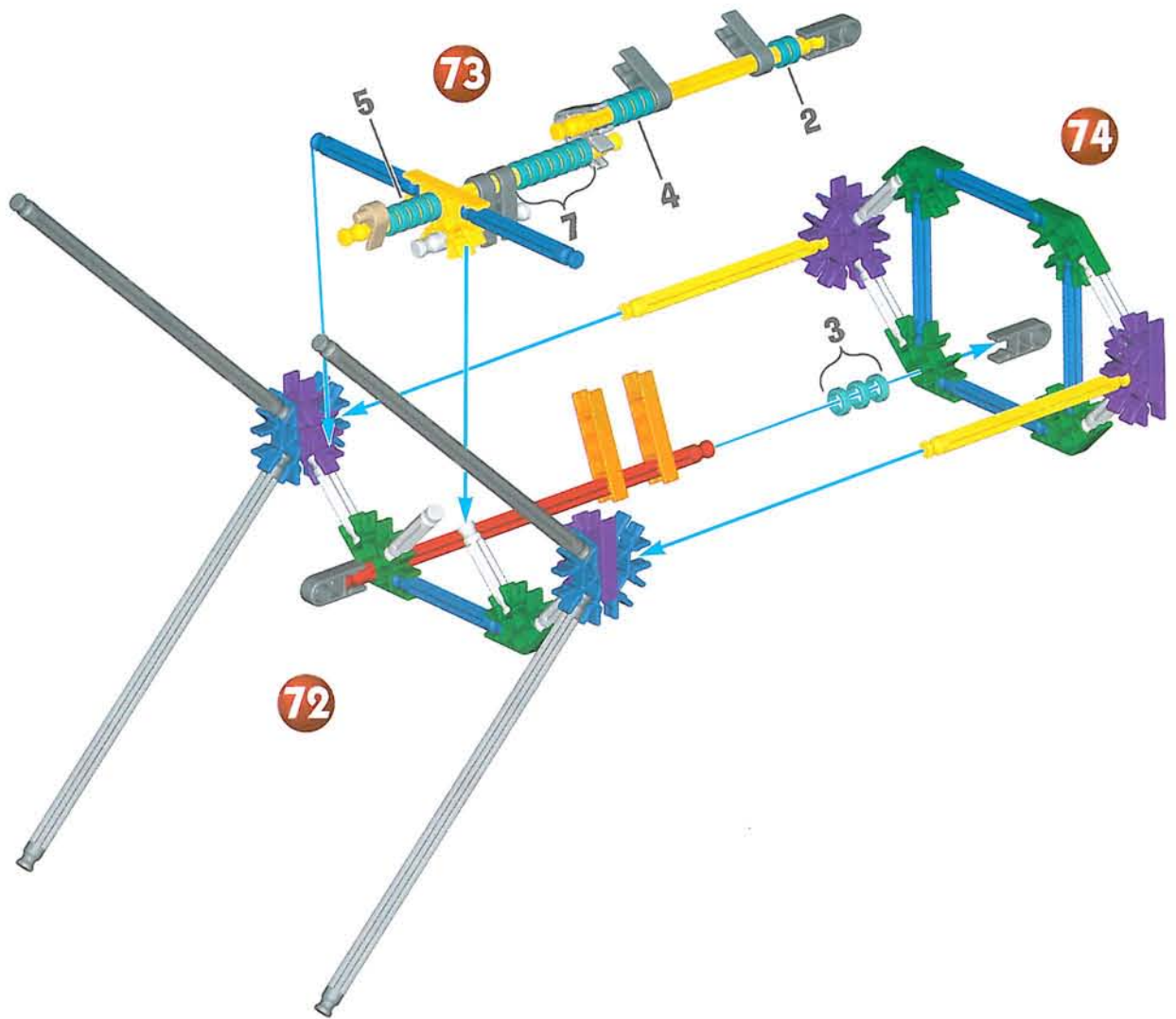

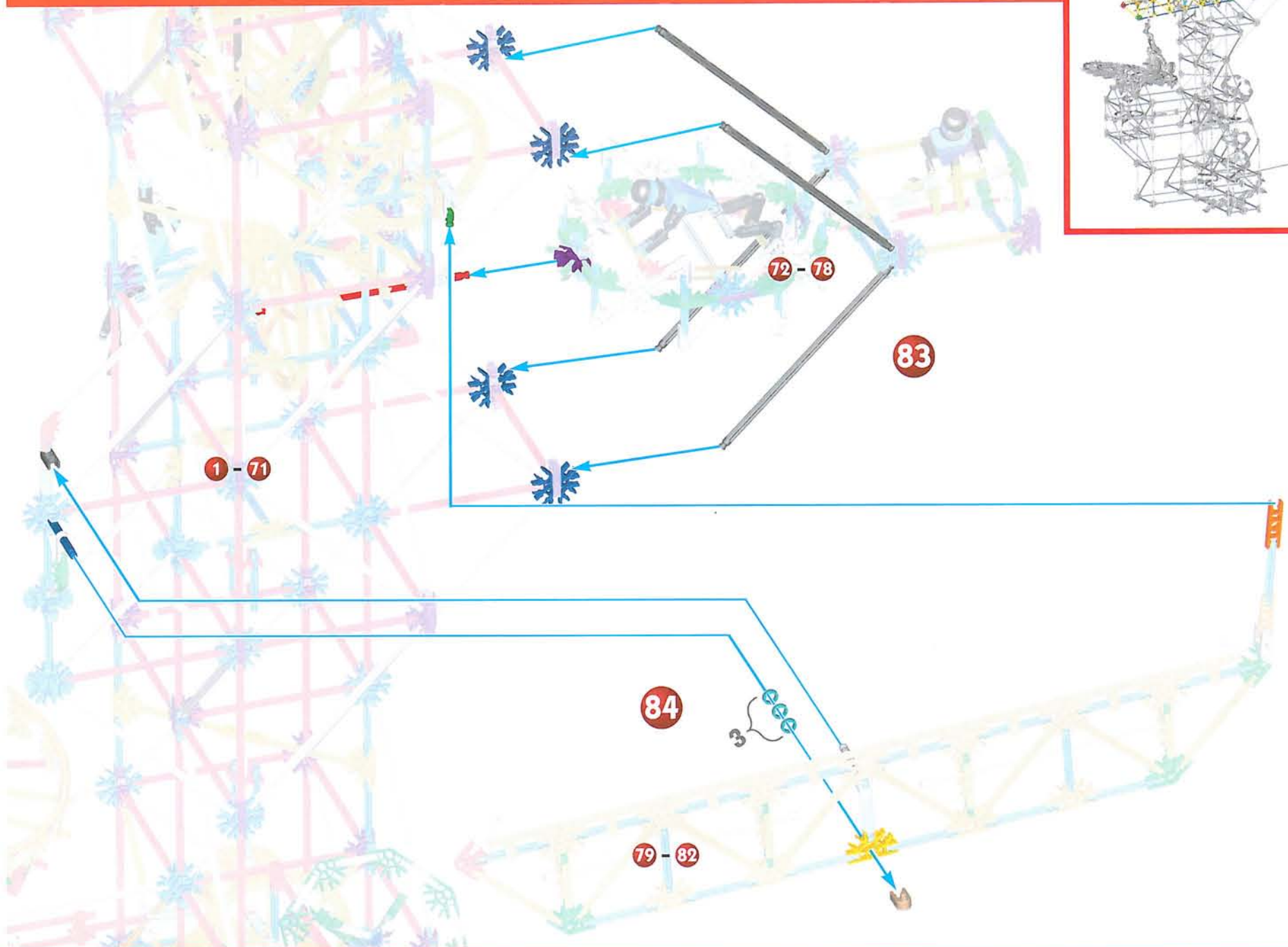
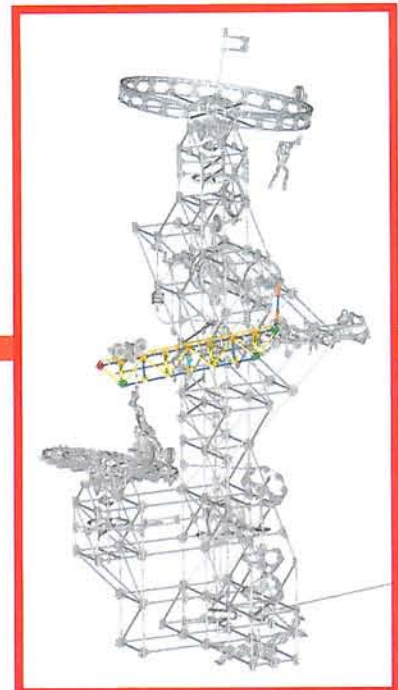
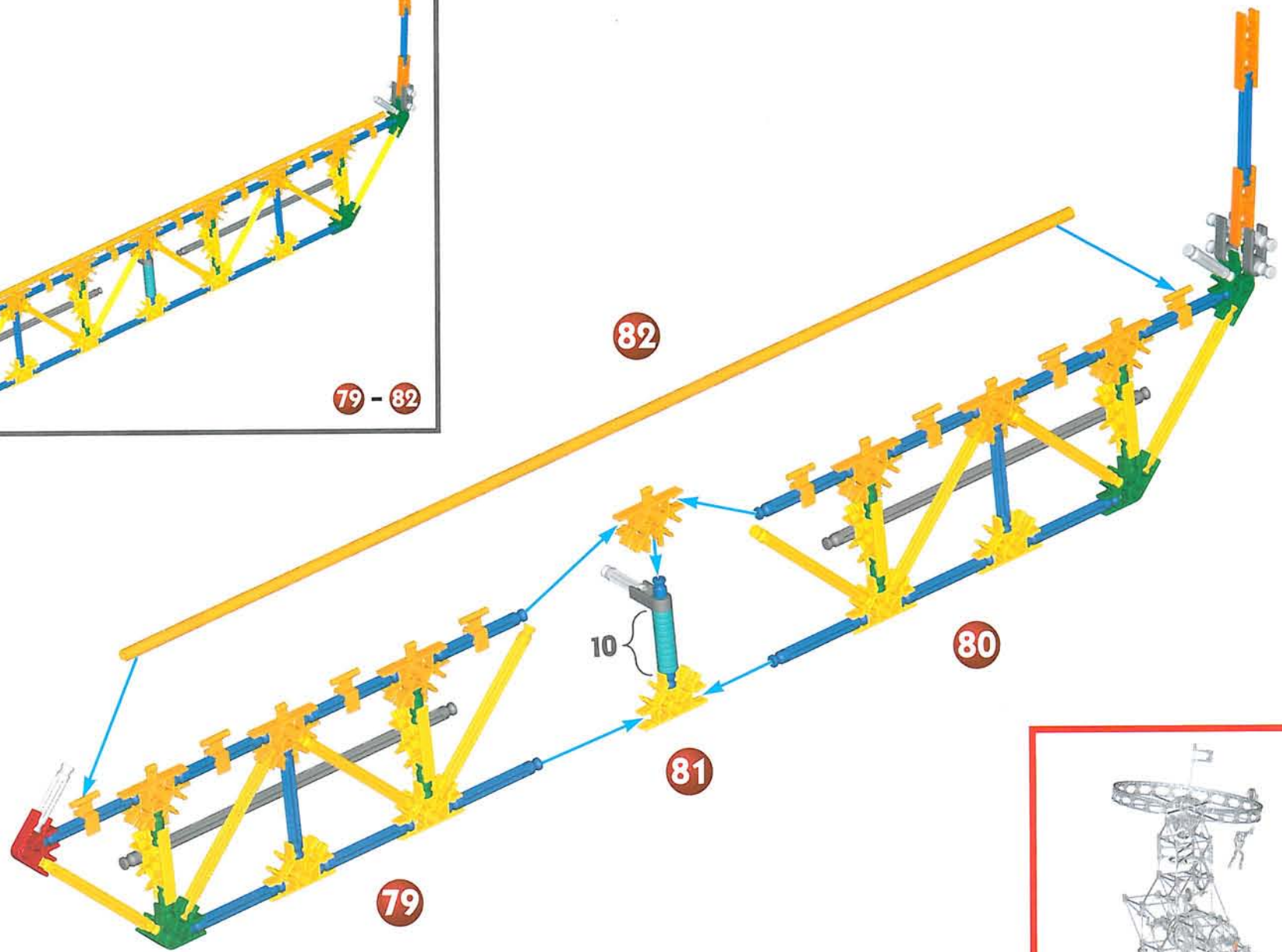
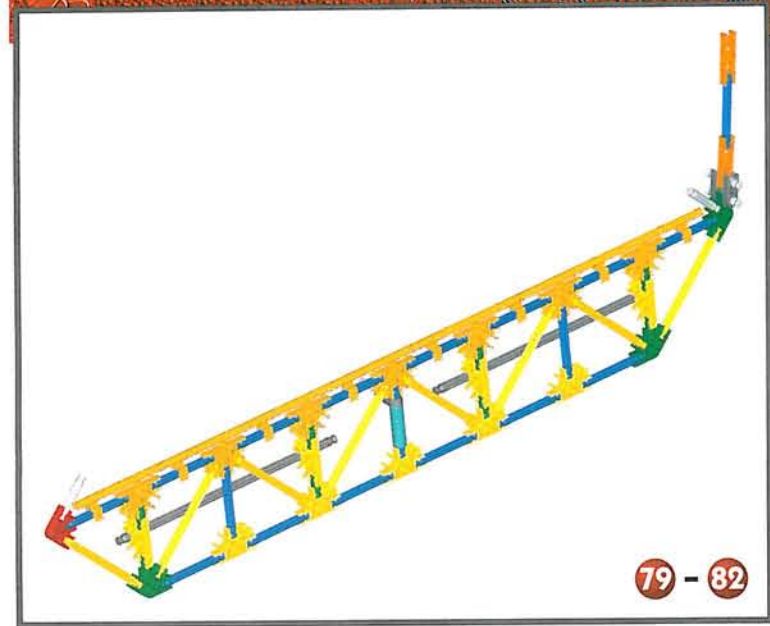

- USA (GB)** Be careful not to tip the model over.
- F** Veillez à ne pas renverser le modèle.
- I** Fare attenzione a non rovesciare il modello.
- D** Darauf achten, daß das Modell nicht umfällt.
- E** Tener cuidado de no volcar el modelo.
- S** Var försiktig så att modellen inte välter.
- DK** Pas på ikke at vælte modellen.
- N** Vær forsiktig slik at du ikke velter modellen.
- SF** Varo, ettei malli kaadu.
- NL** Laat het model niet omkantelen.
- P** Tenha cuidado para não derrubar o modelo.
- G** Προσέξτε μη ρίξετε το μοντέλο.
- TR** Modelin devrilmemesine dikkat edin.
- J** モデルが欠けないようご注意ください。
- CHI** 小心勿推倒模型。
- IL** הקפד לא להפיל את הדגם.

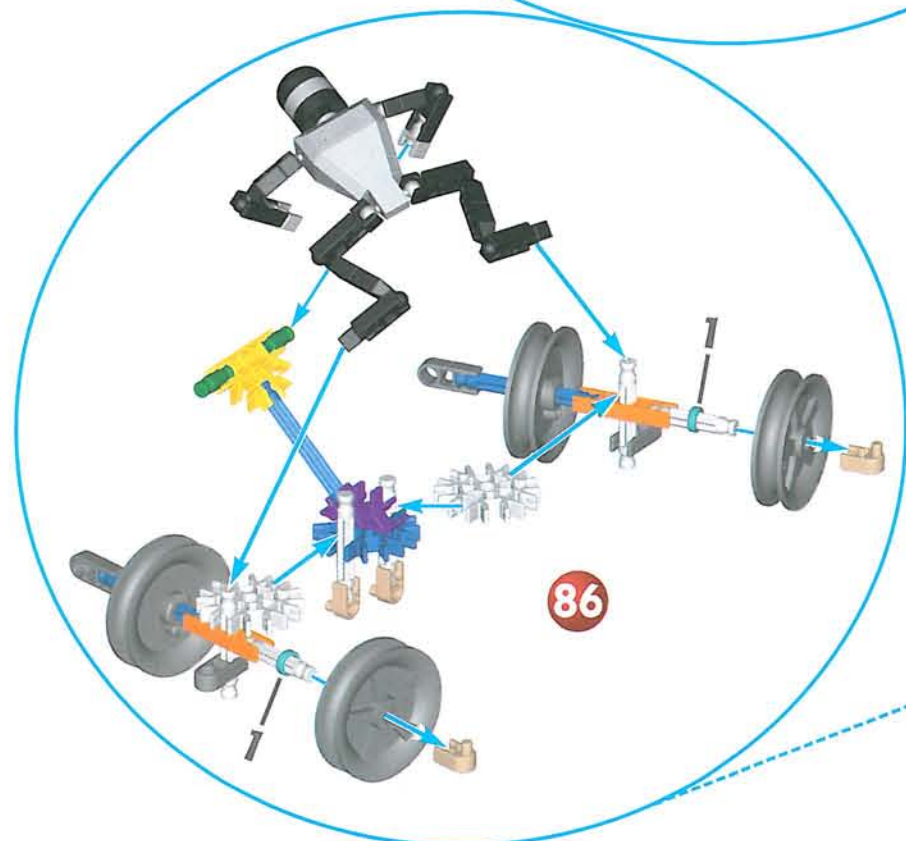
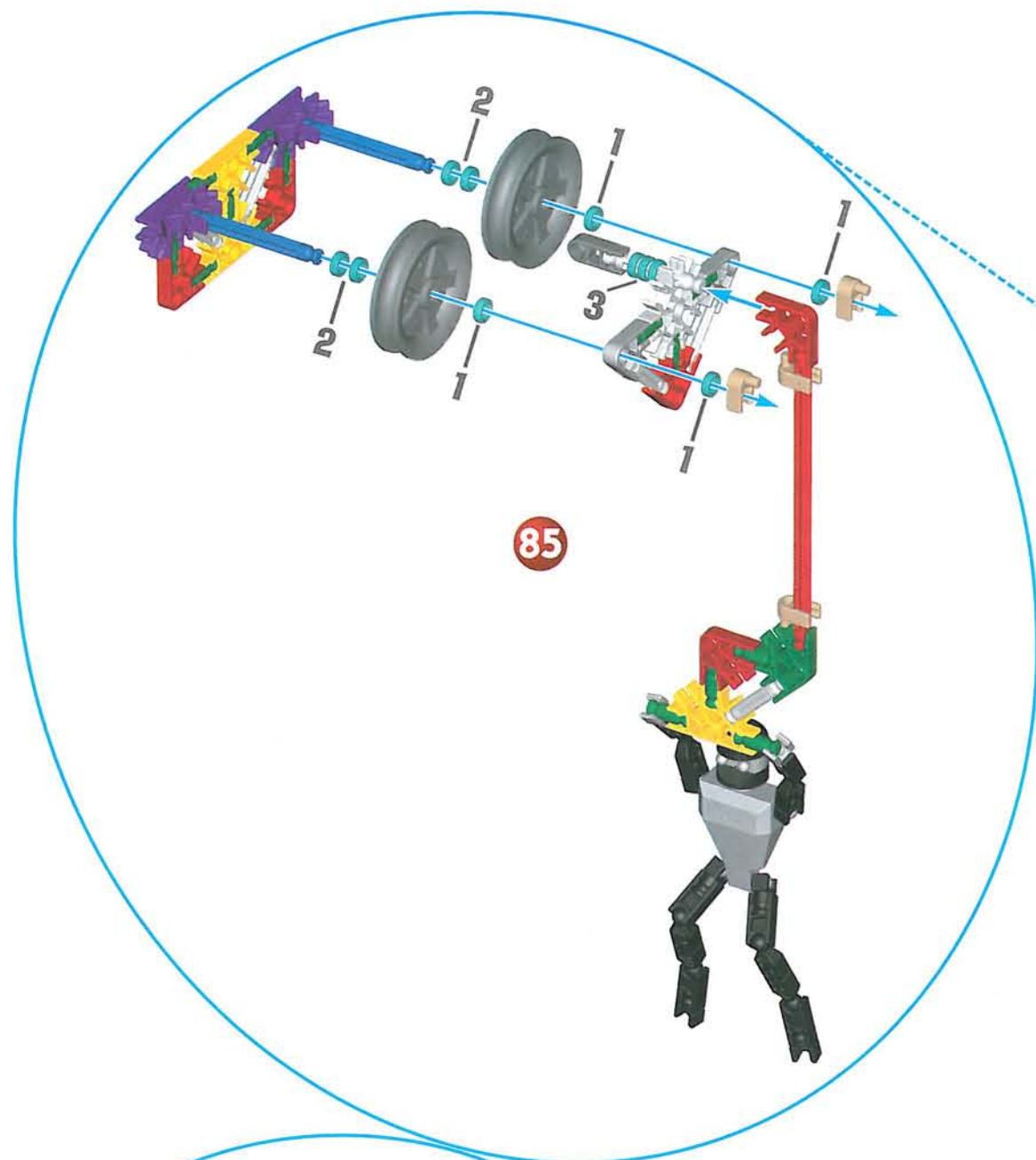

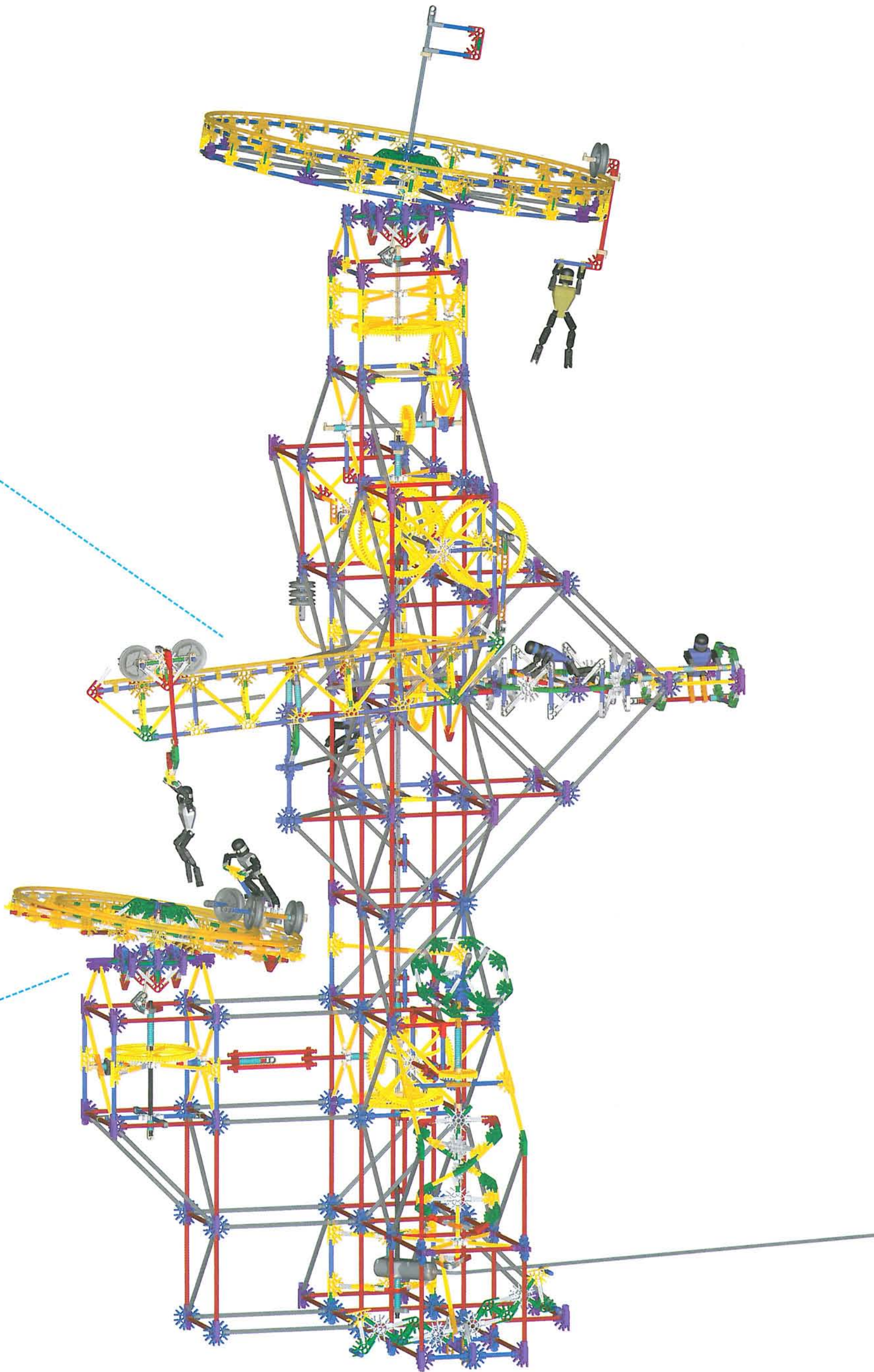

VERTICAL TAKEOFF MODULE

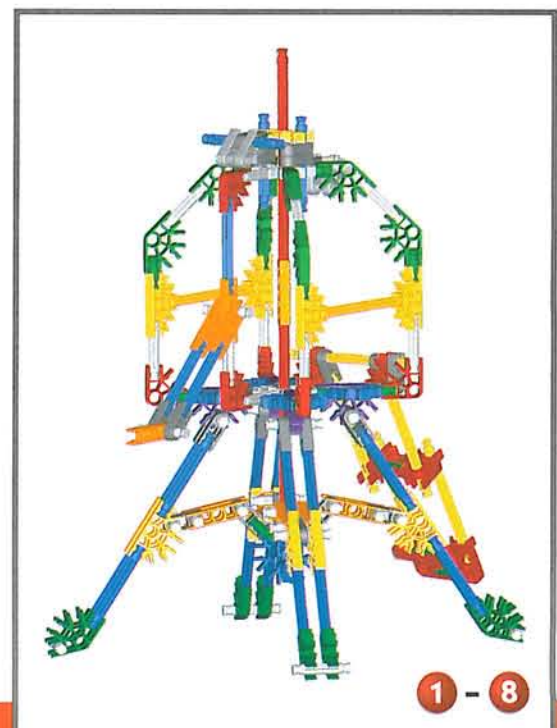
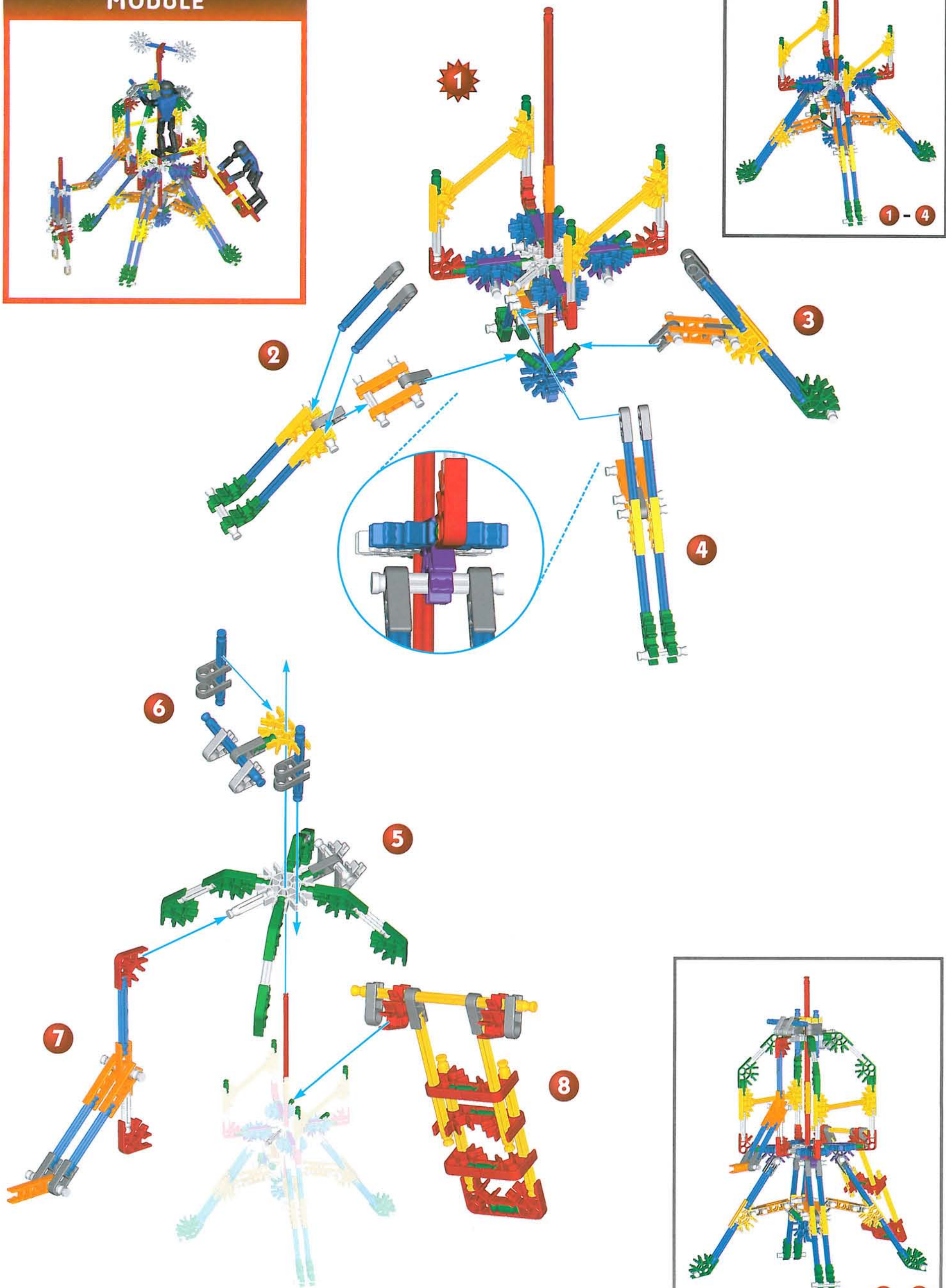
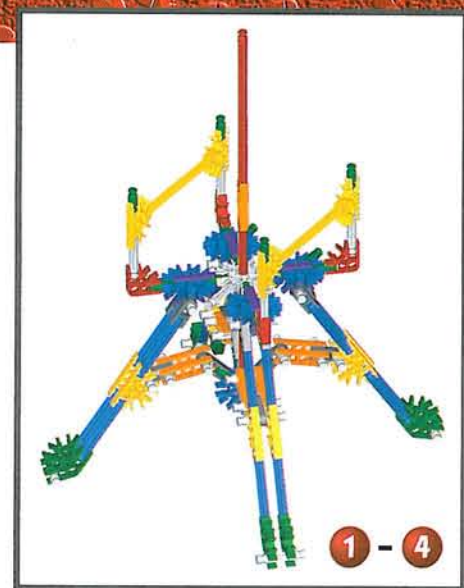
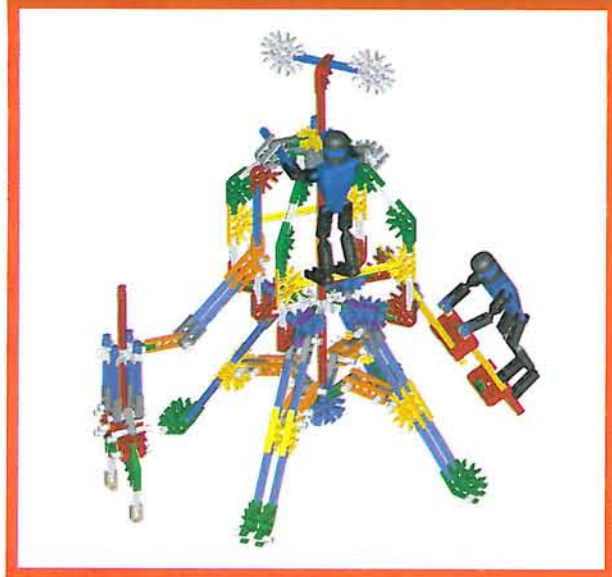

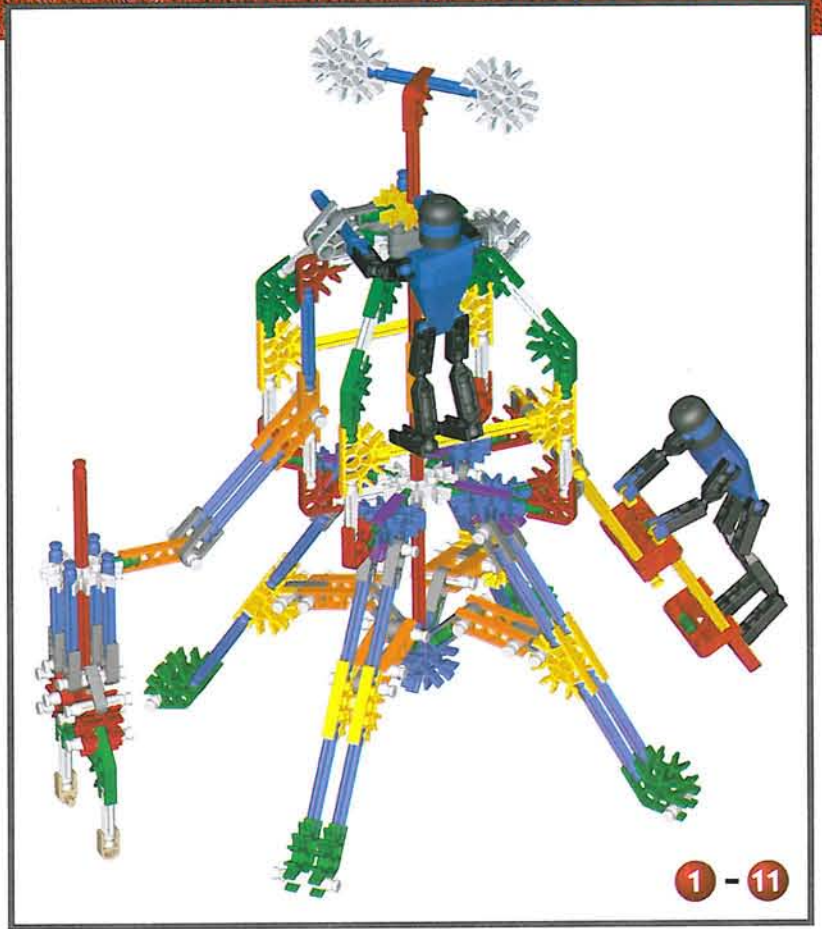
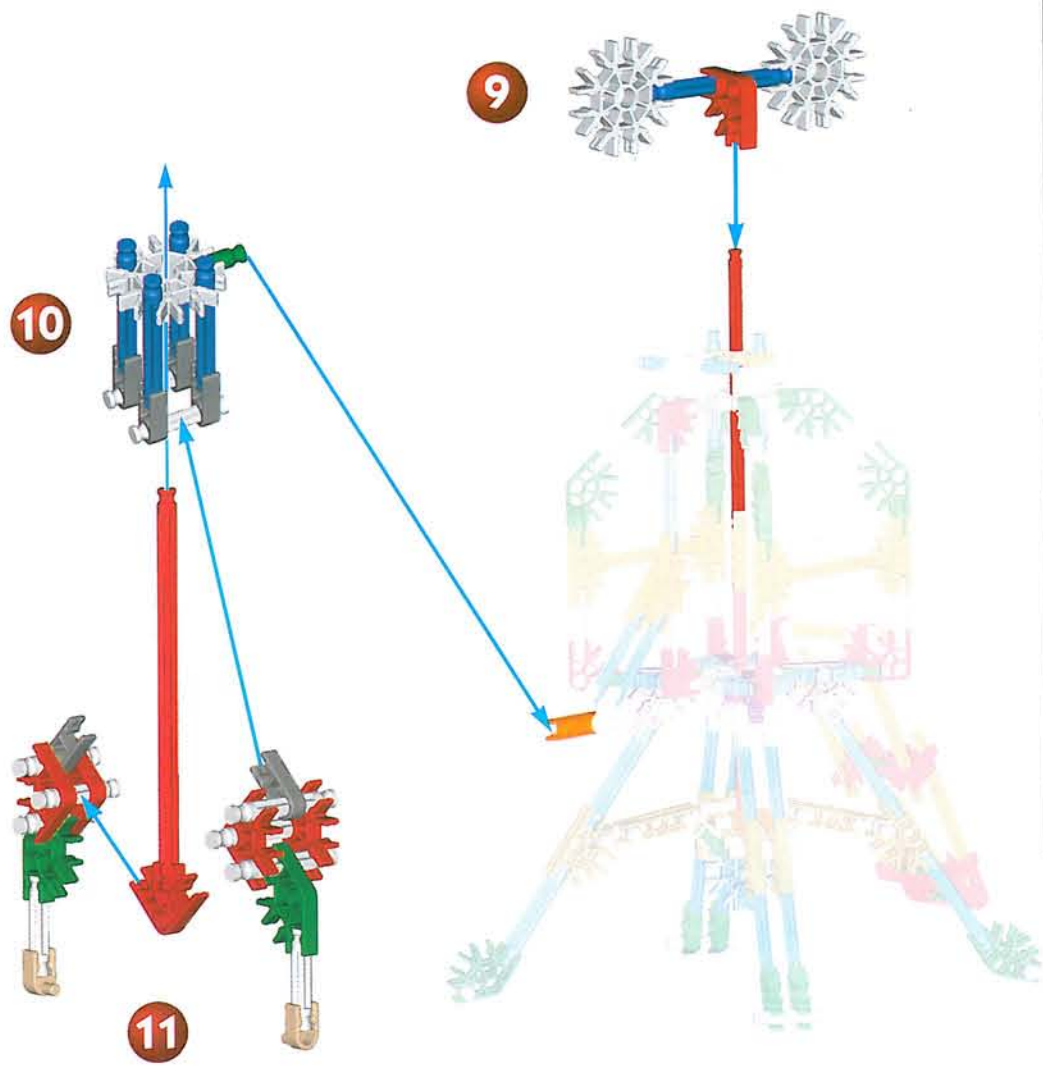

ROCKET PACK TRAINER

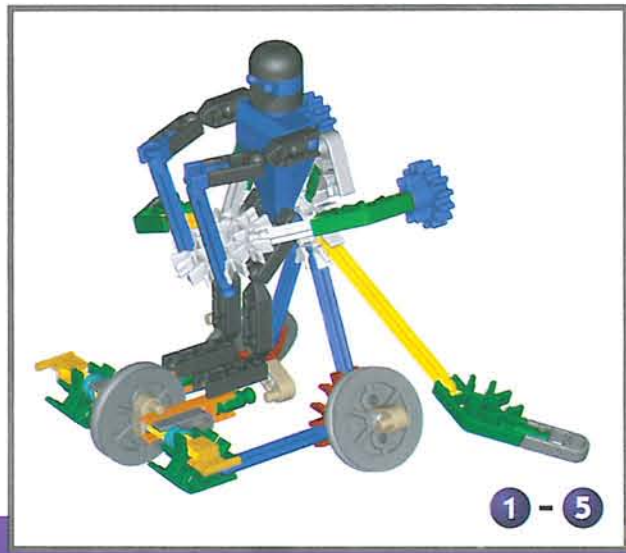
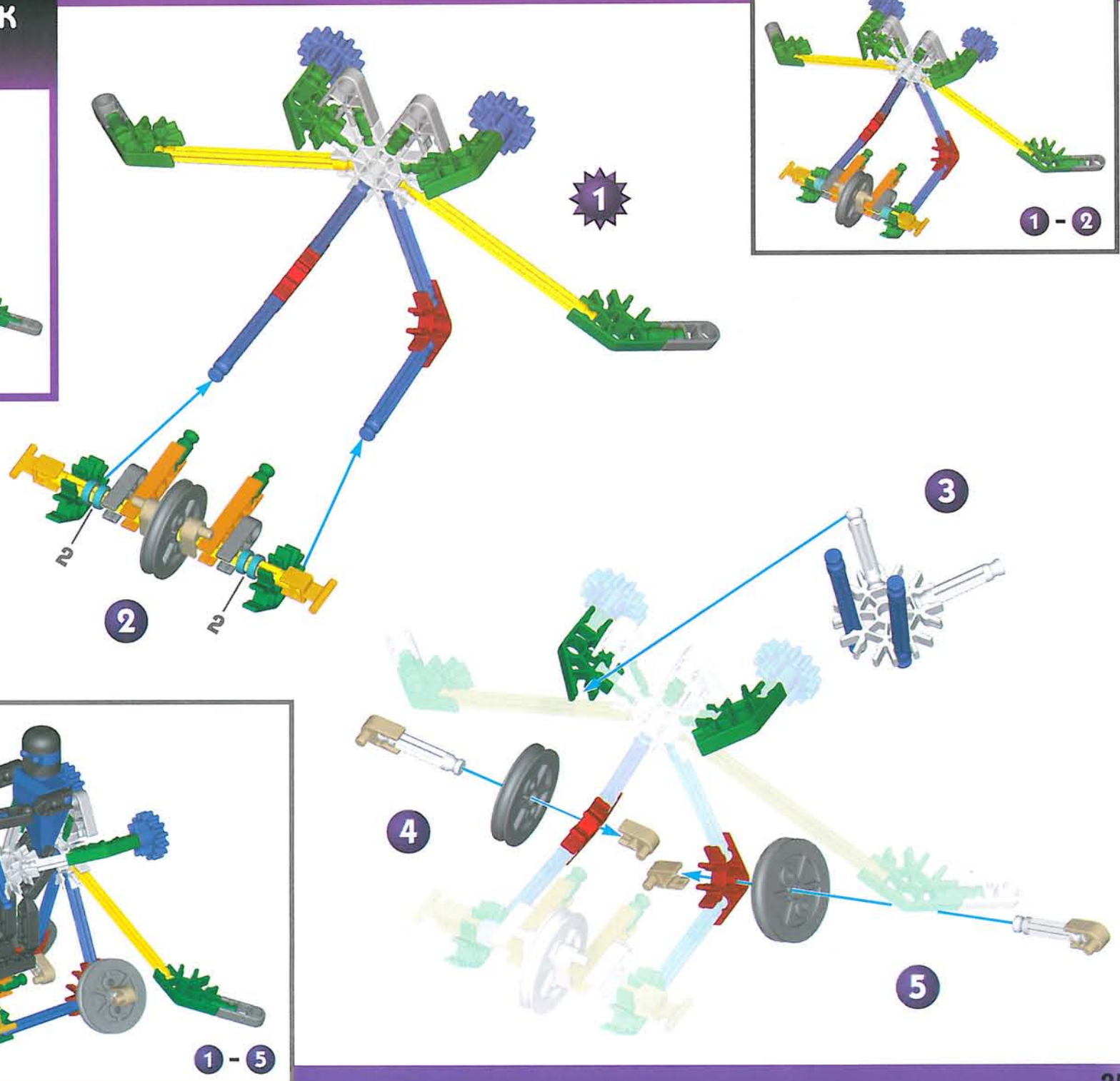

STRIKE TRAINER

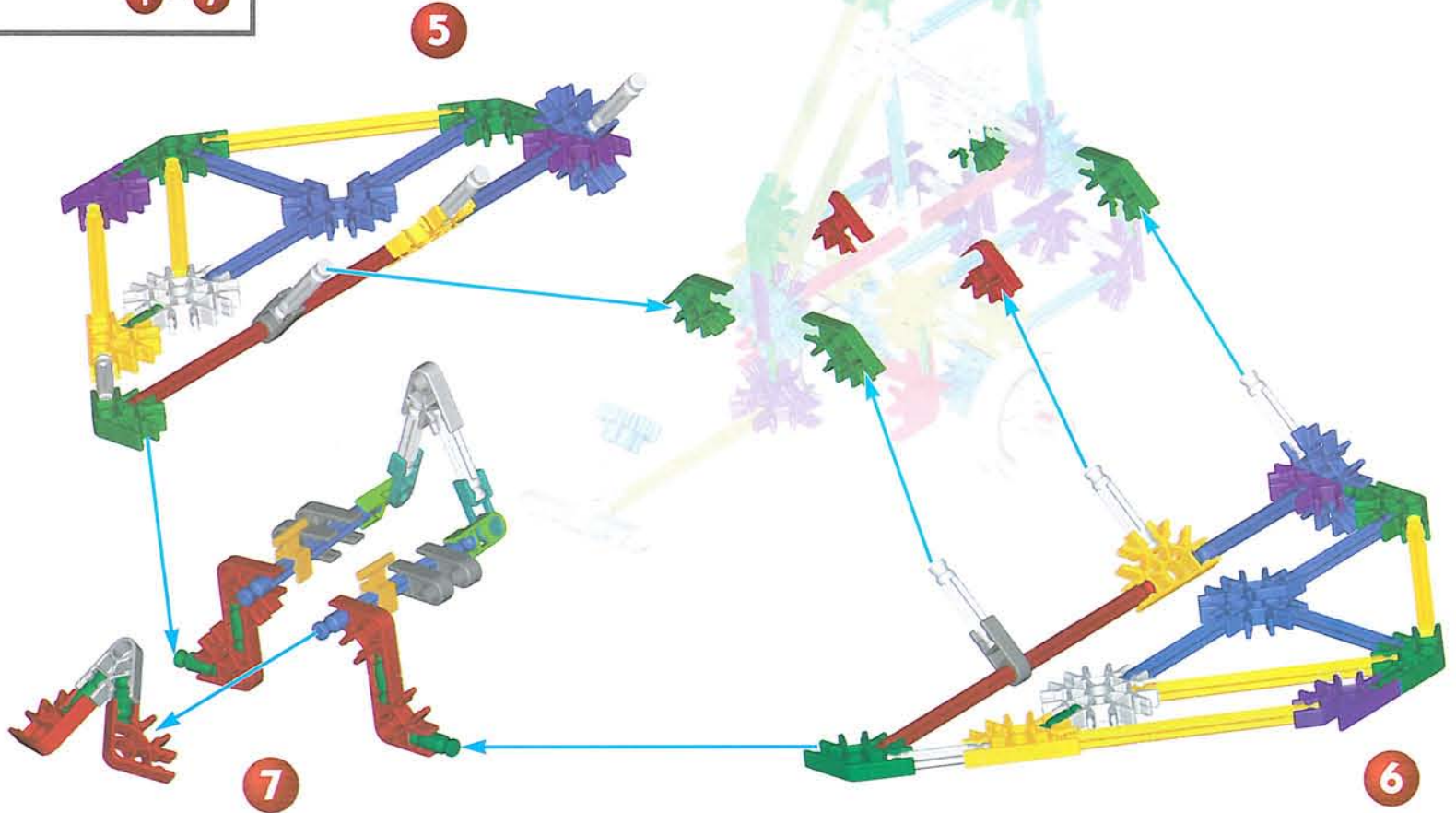
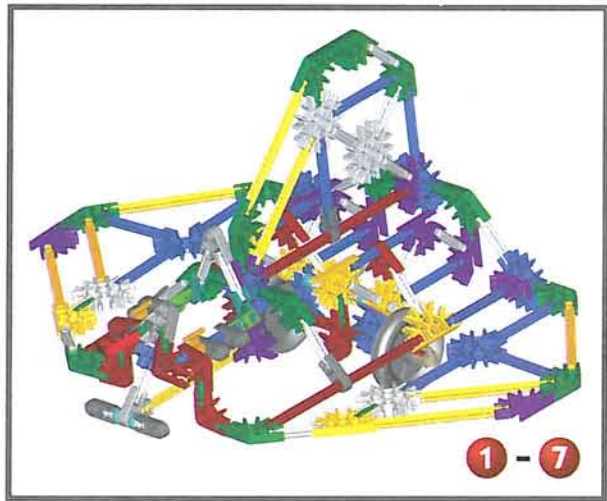
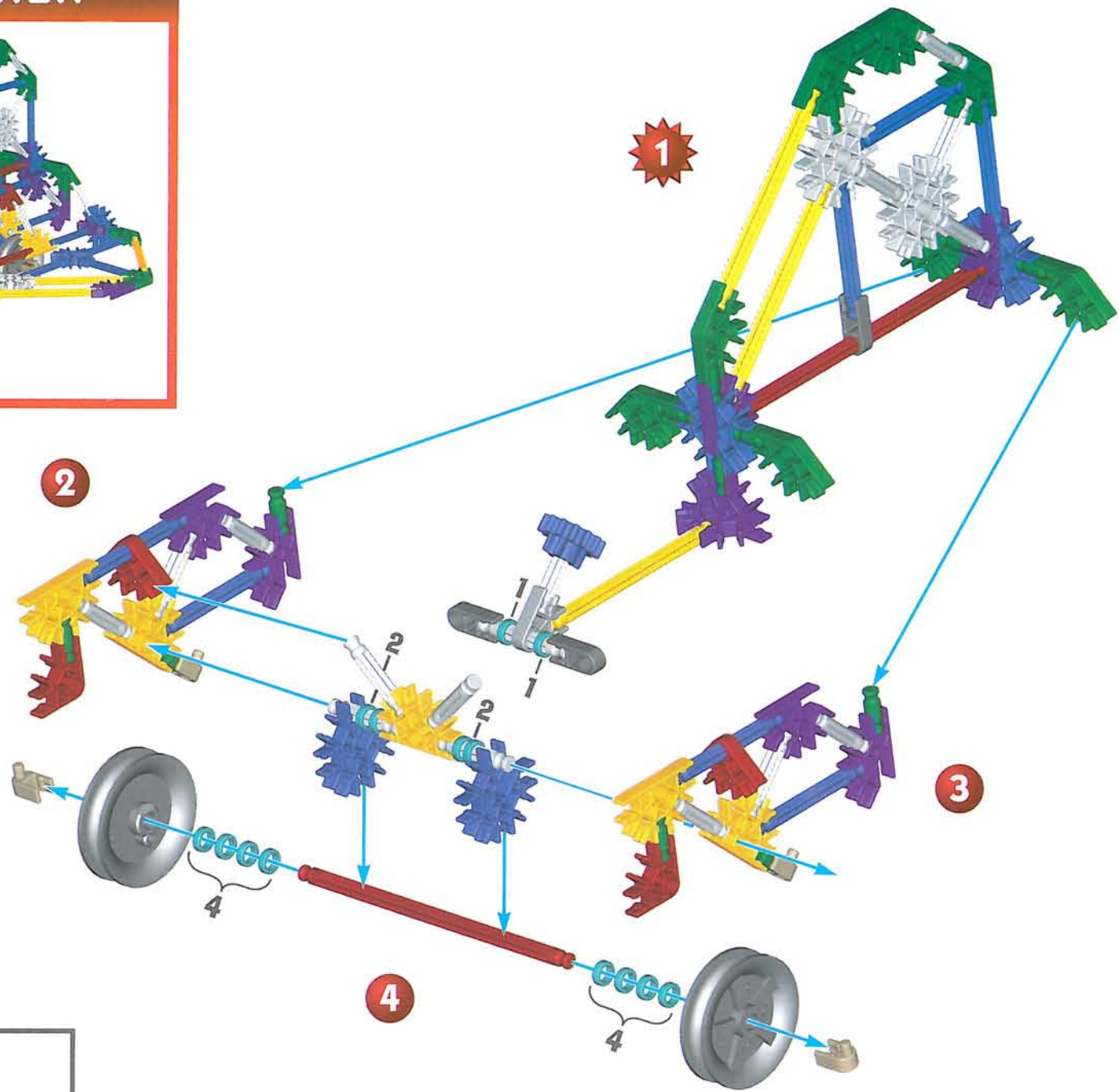
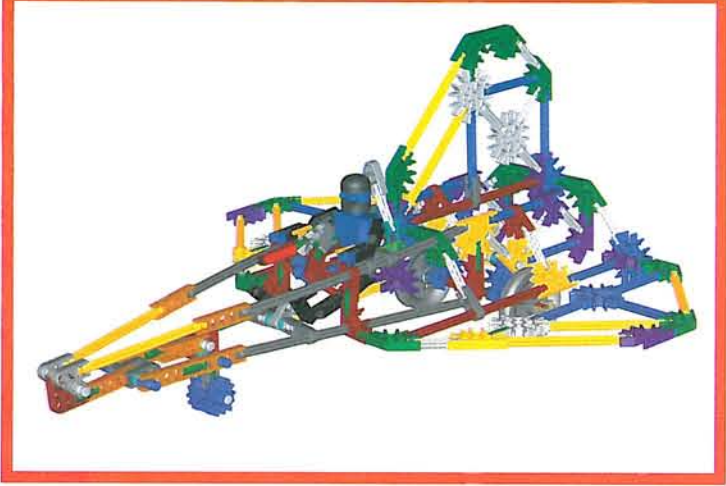

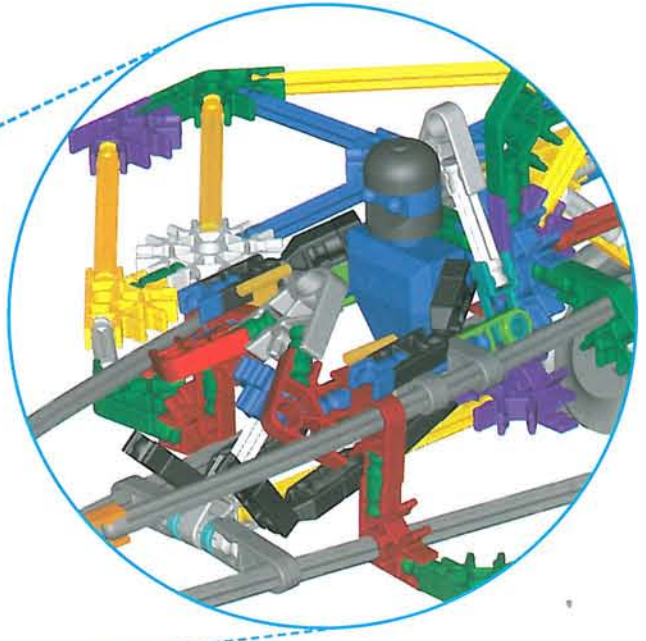
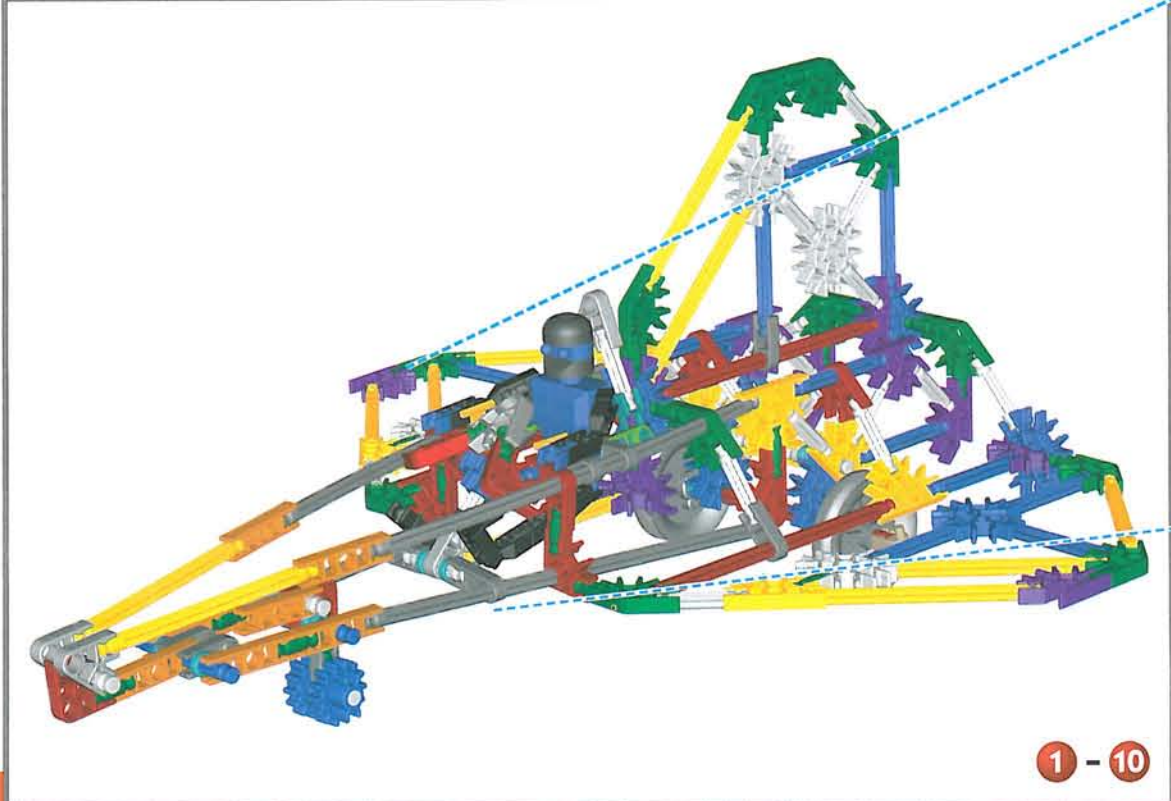
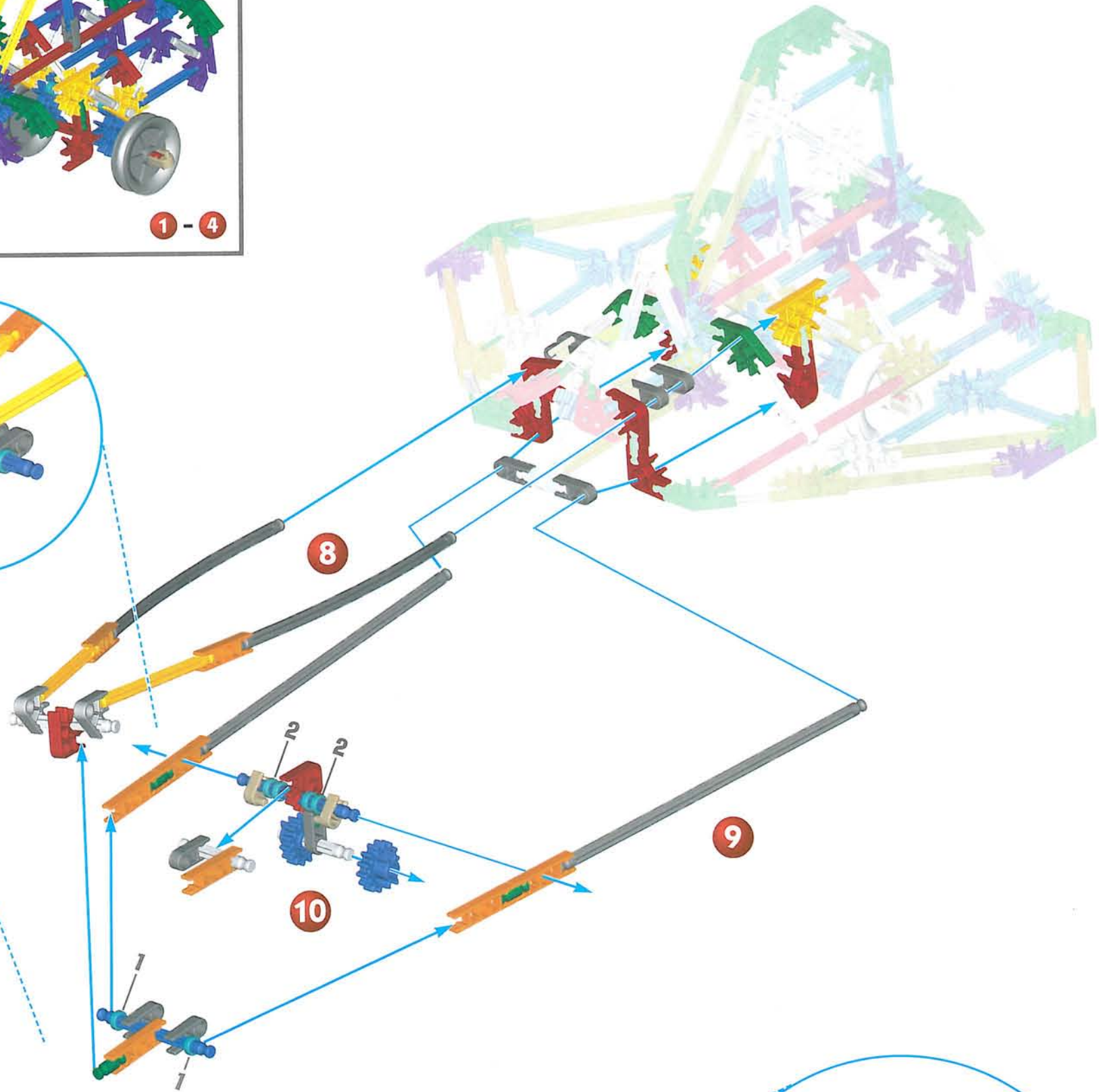
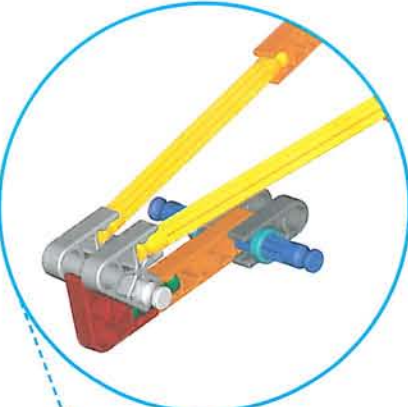

HYPERSPACE LOOKOUT TOWER

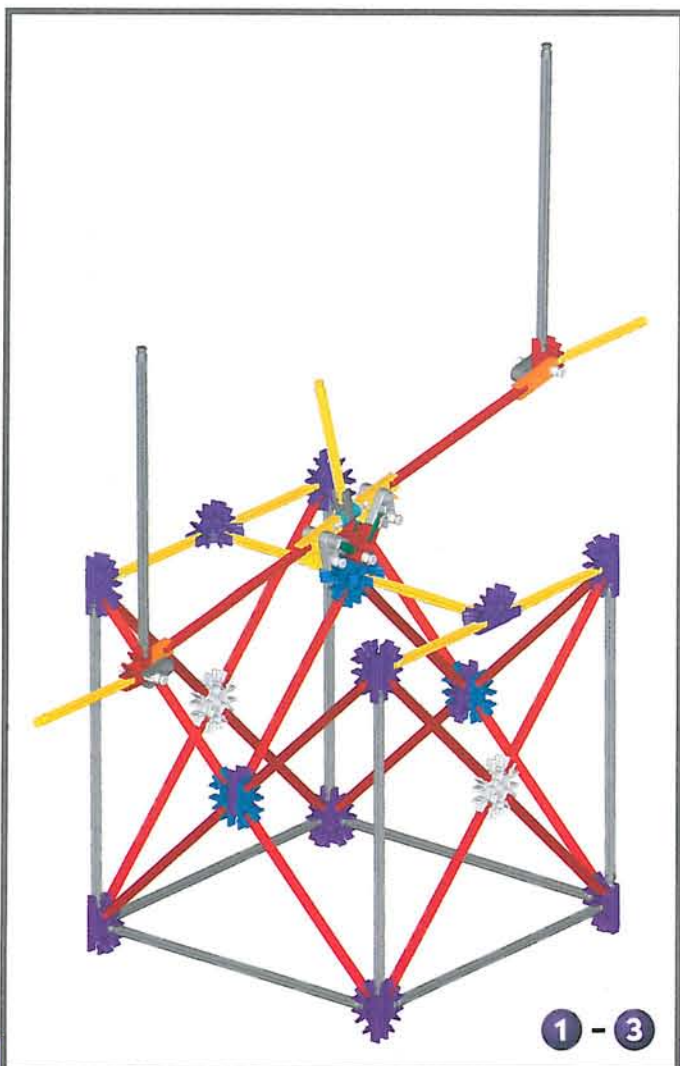
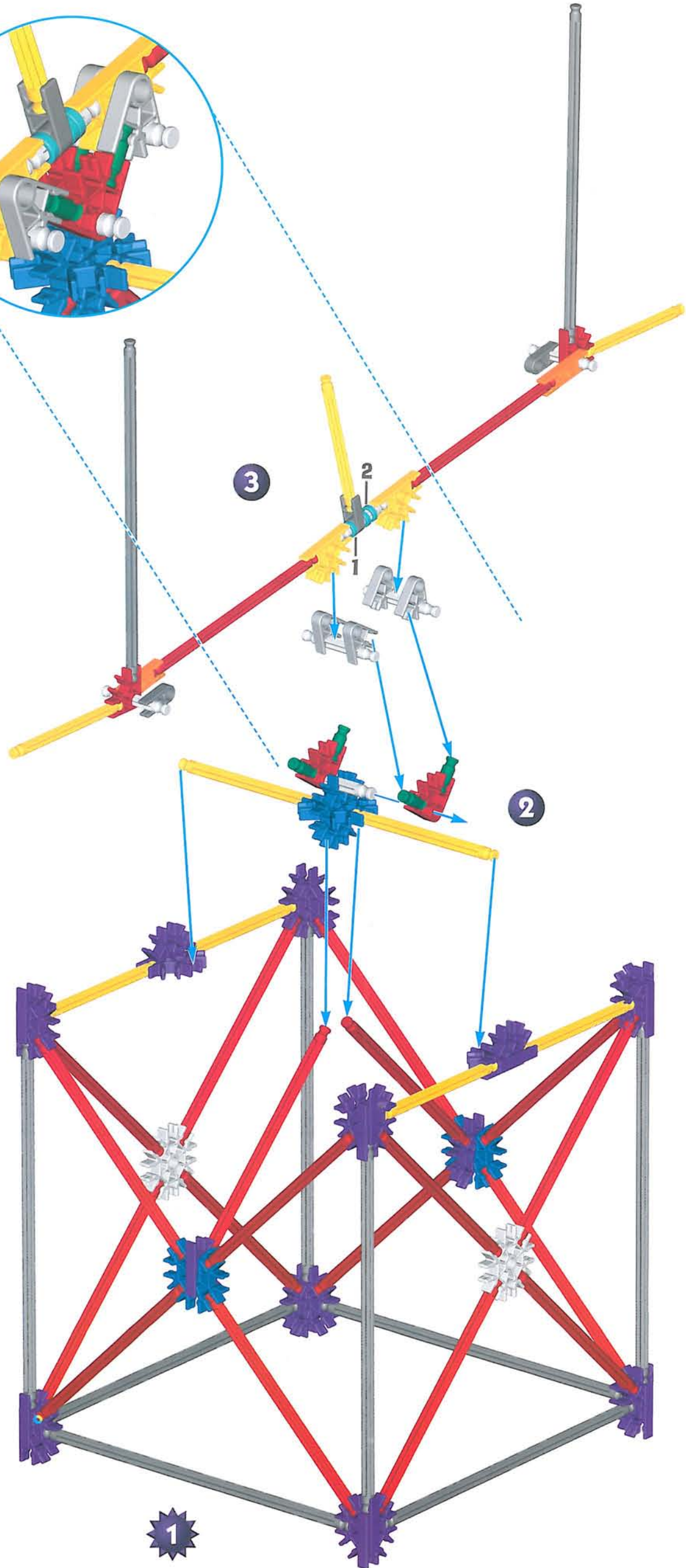
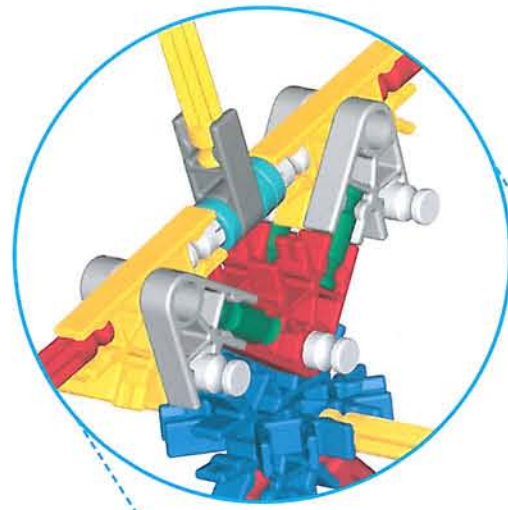
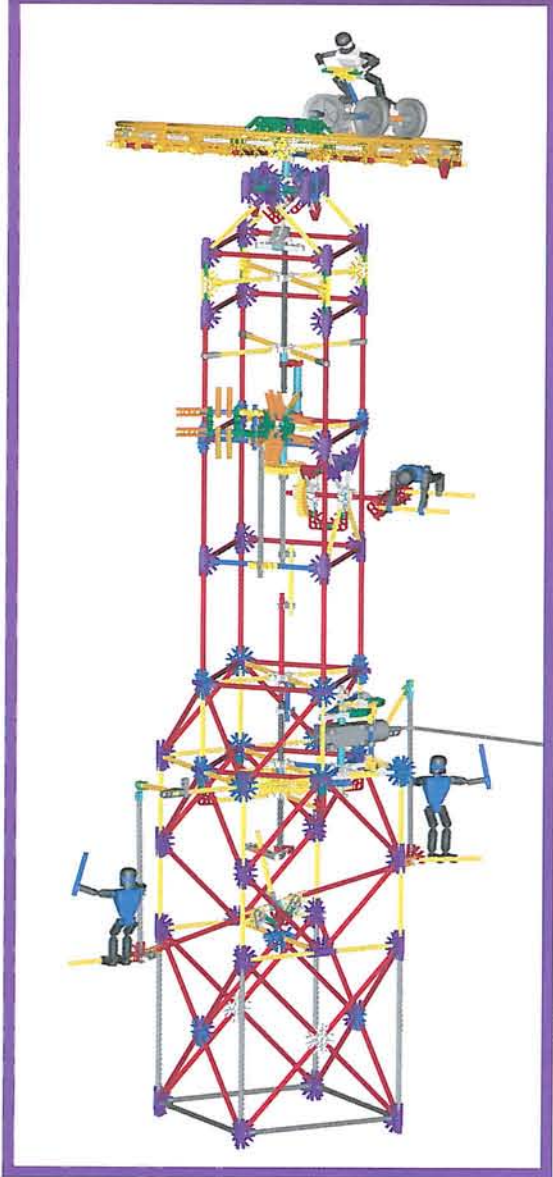

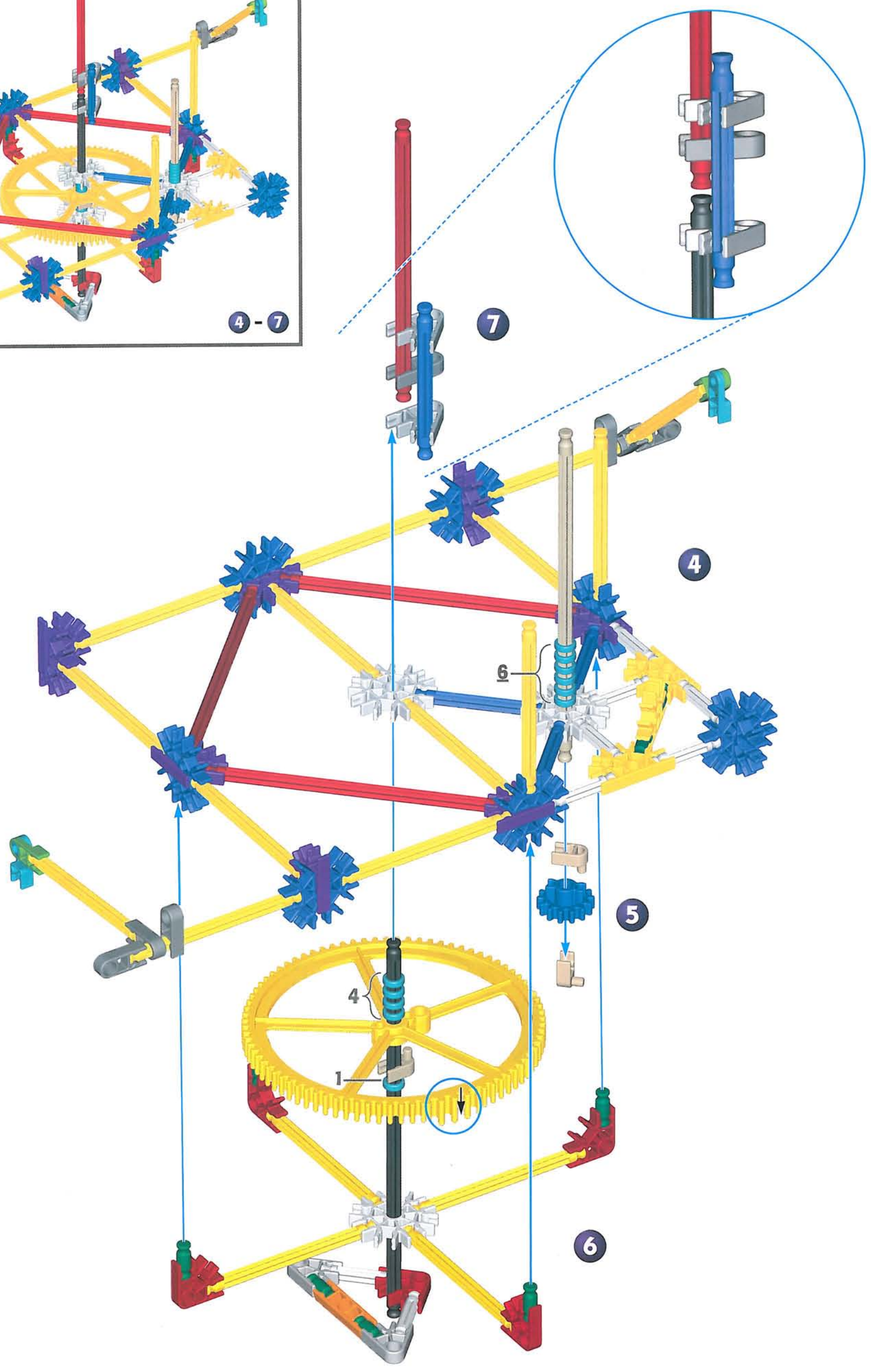
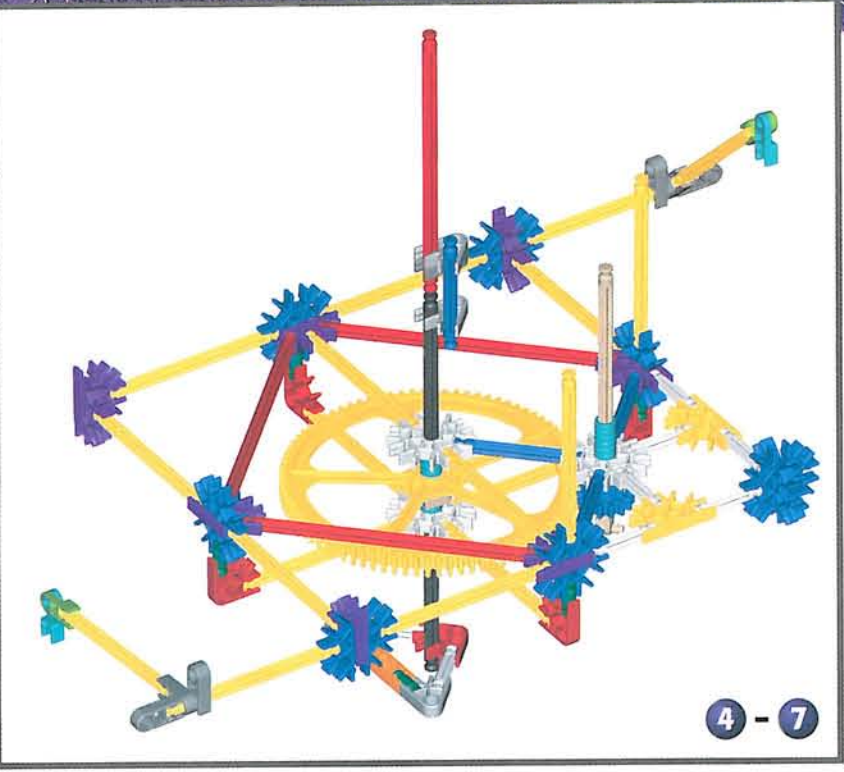

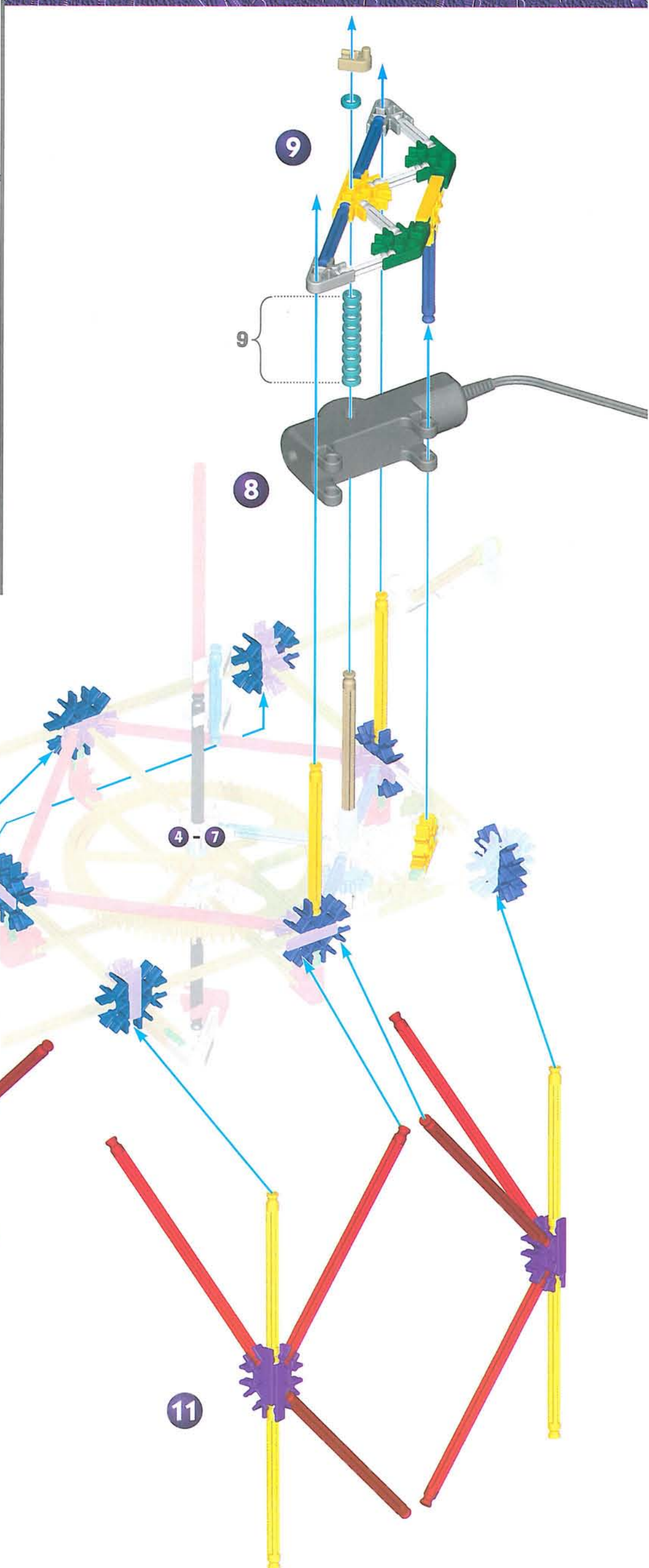
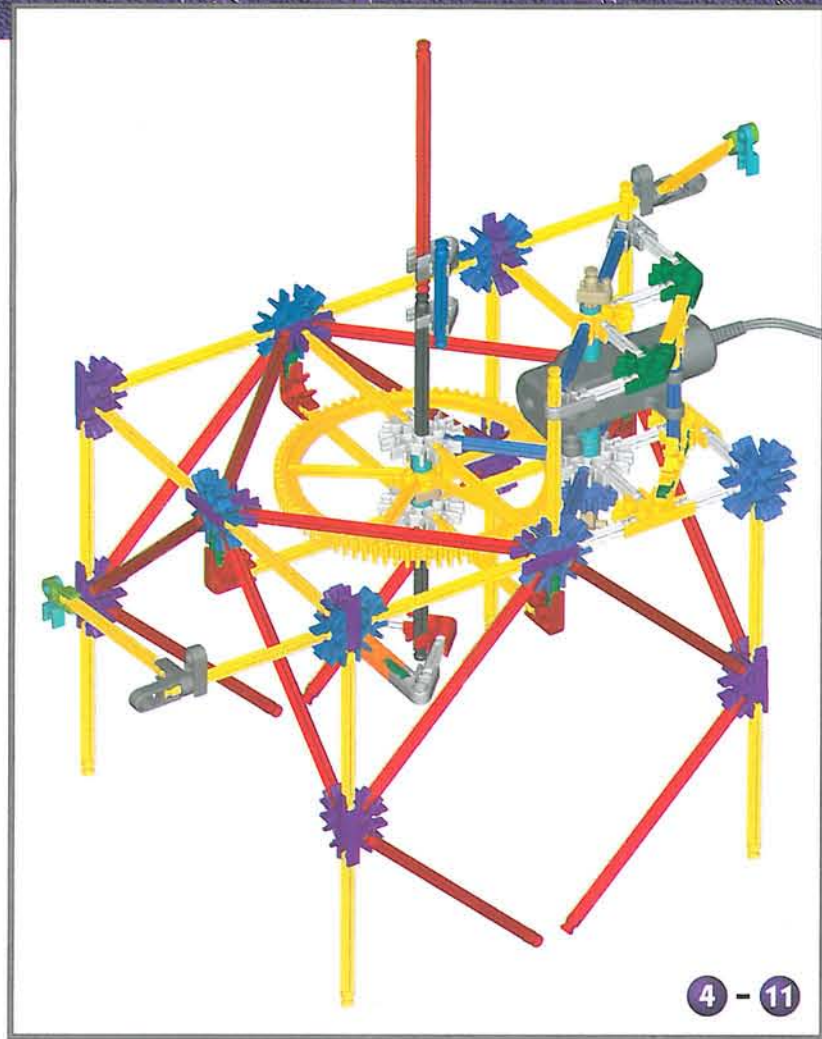

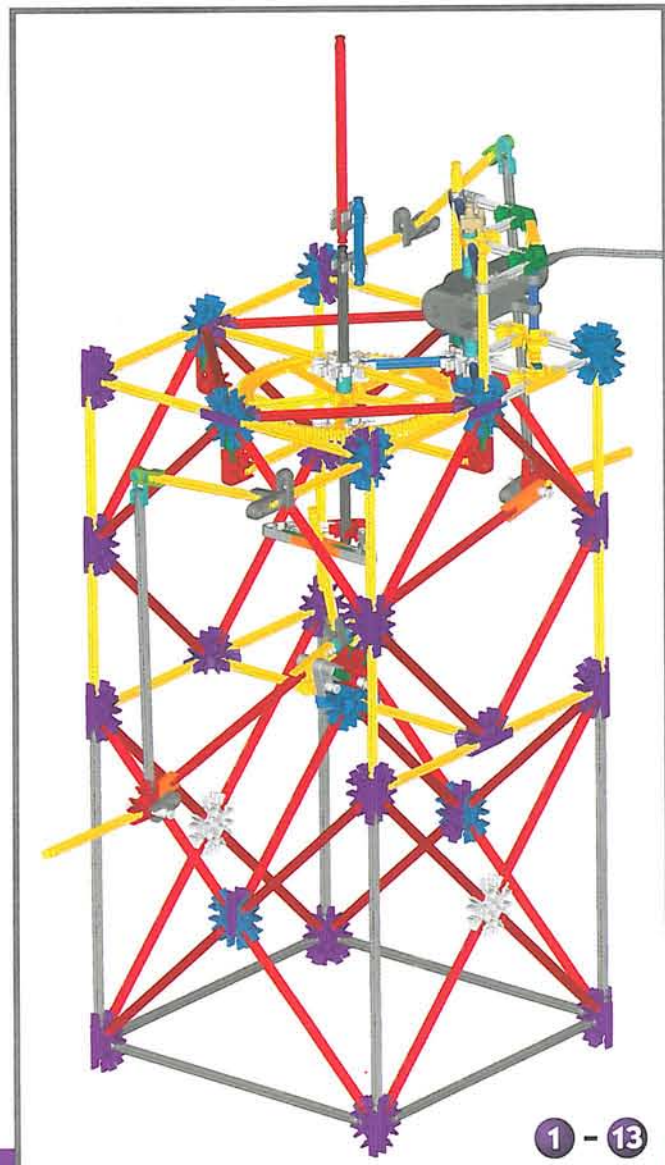
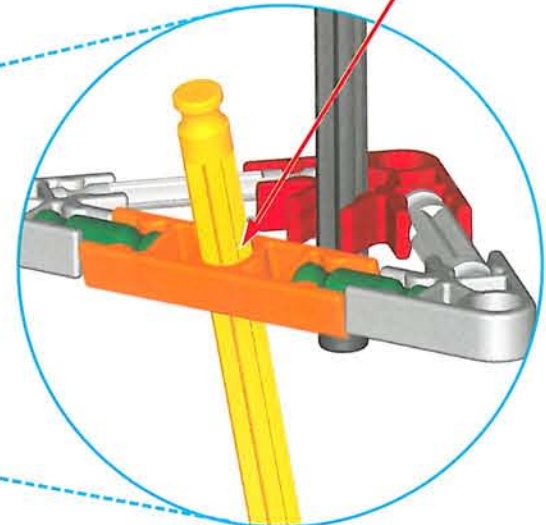
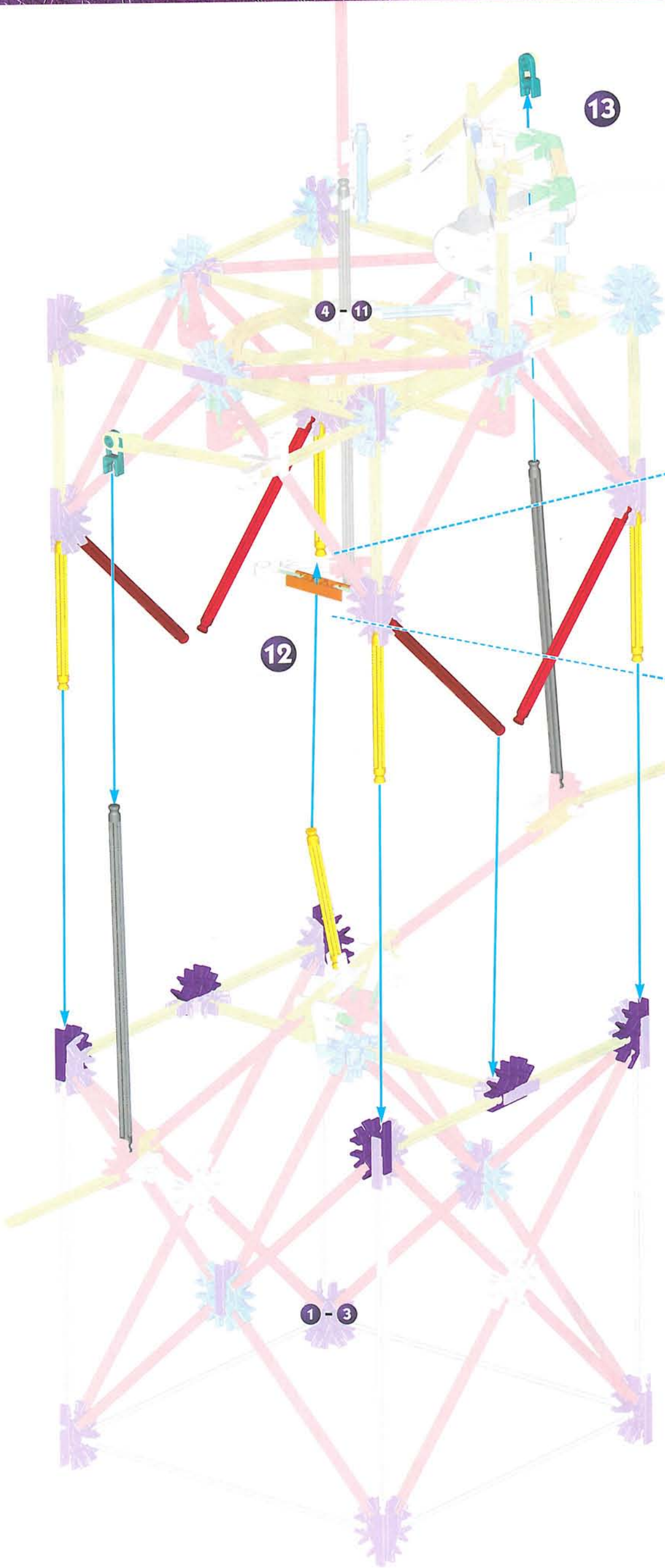

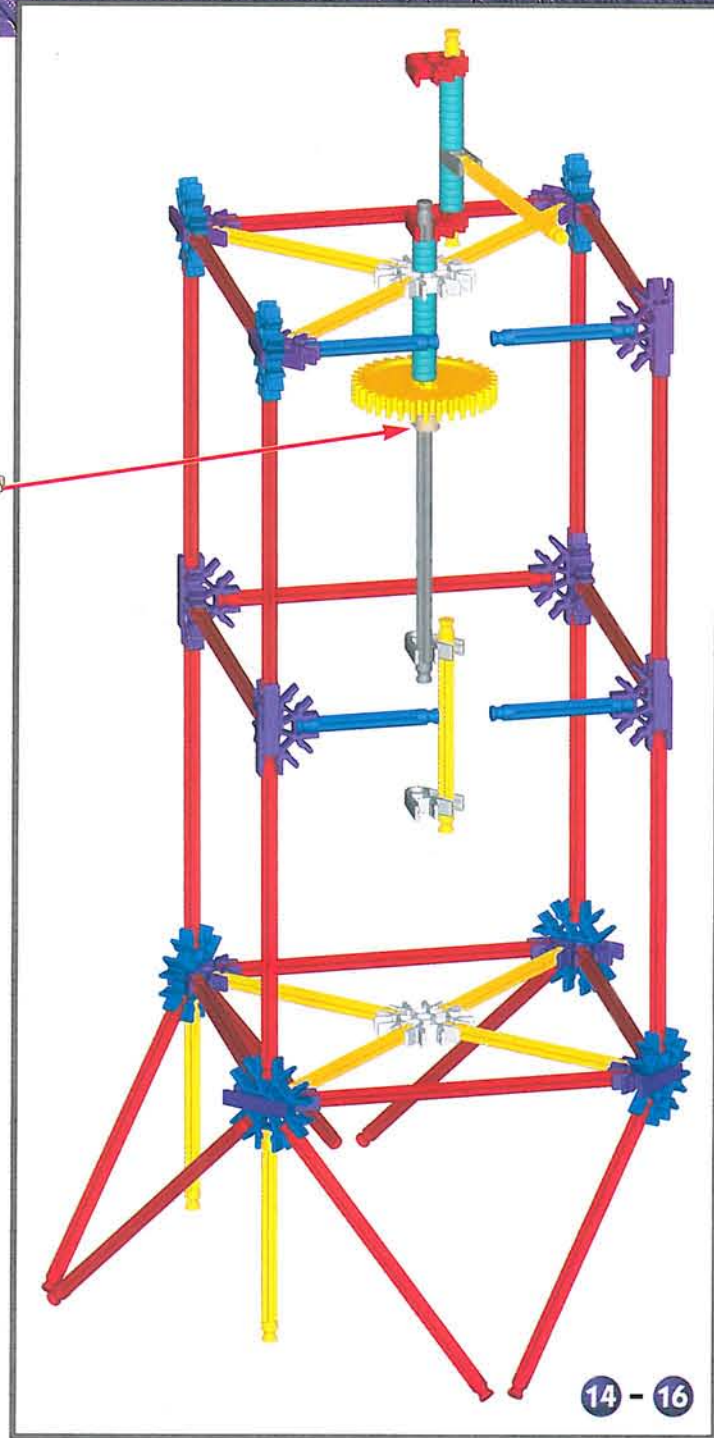
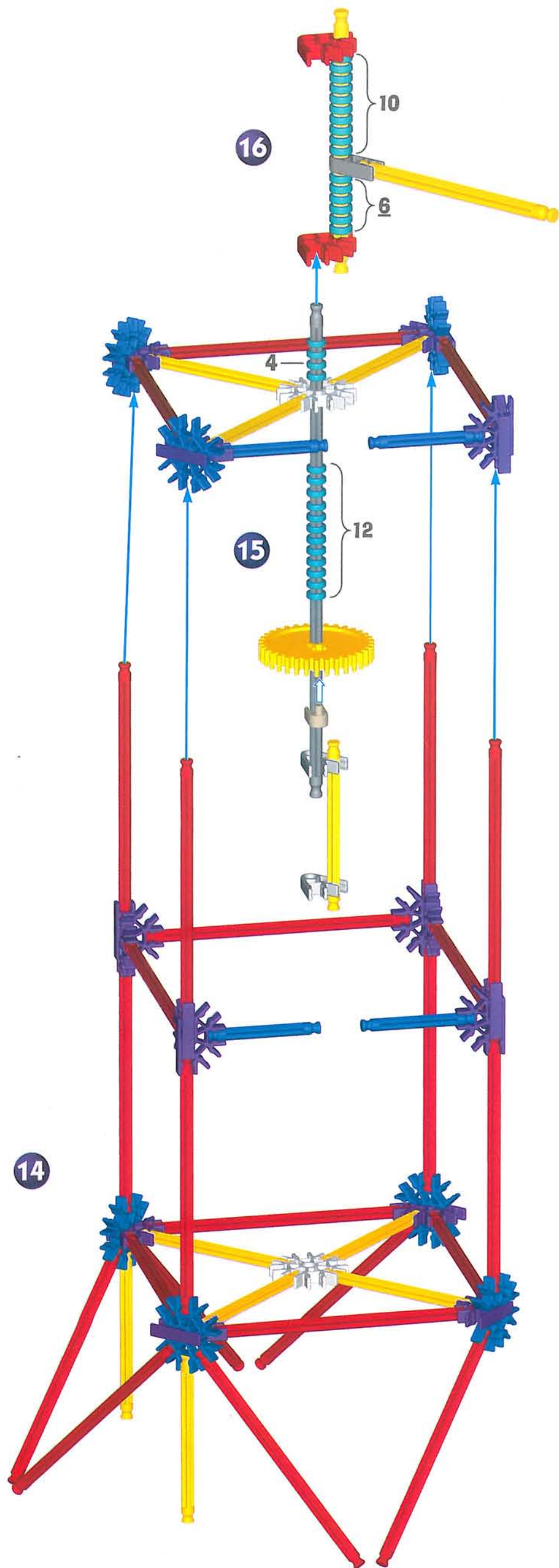

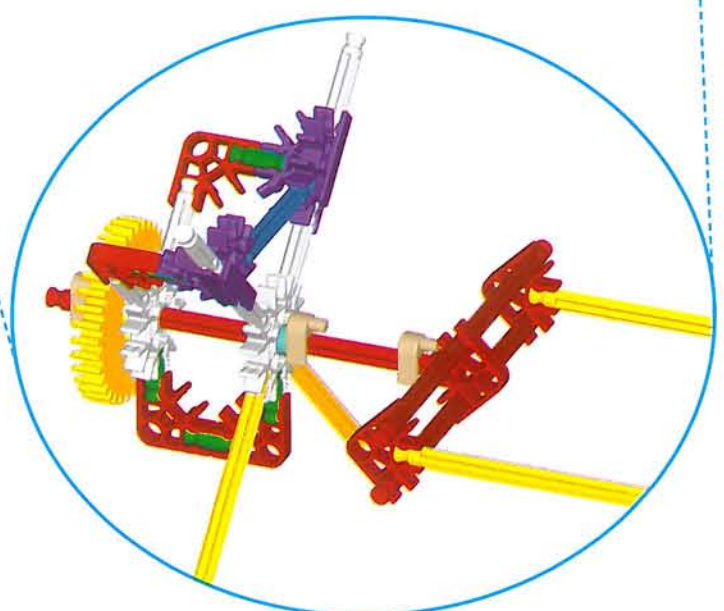
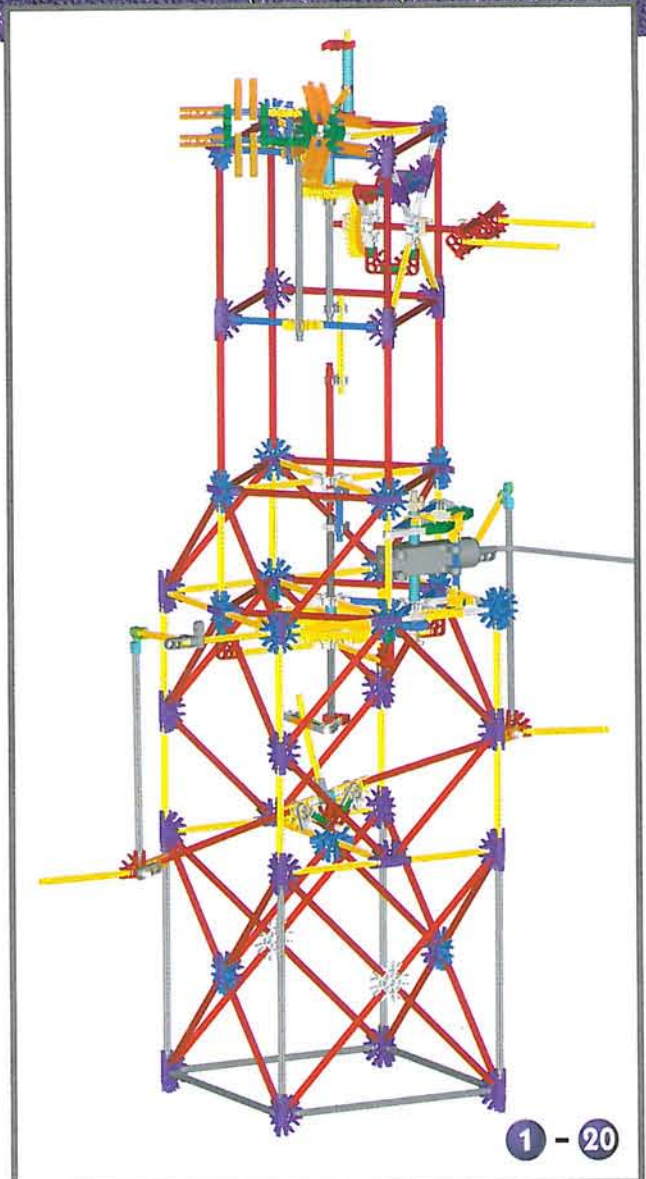
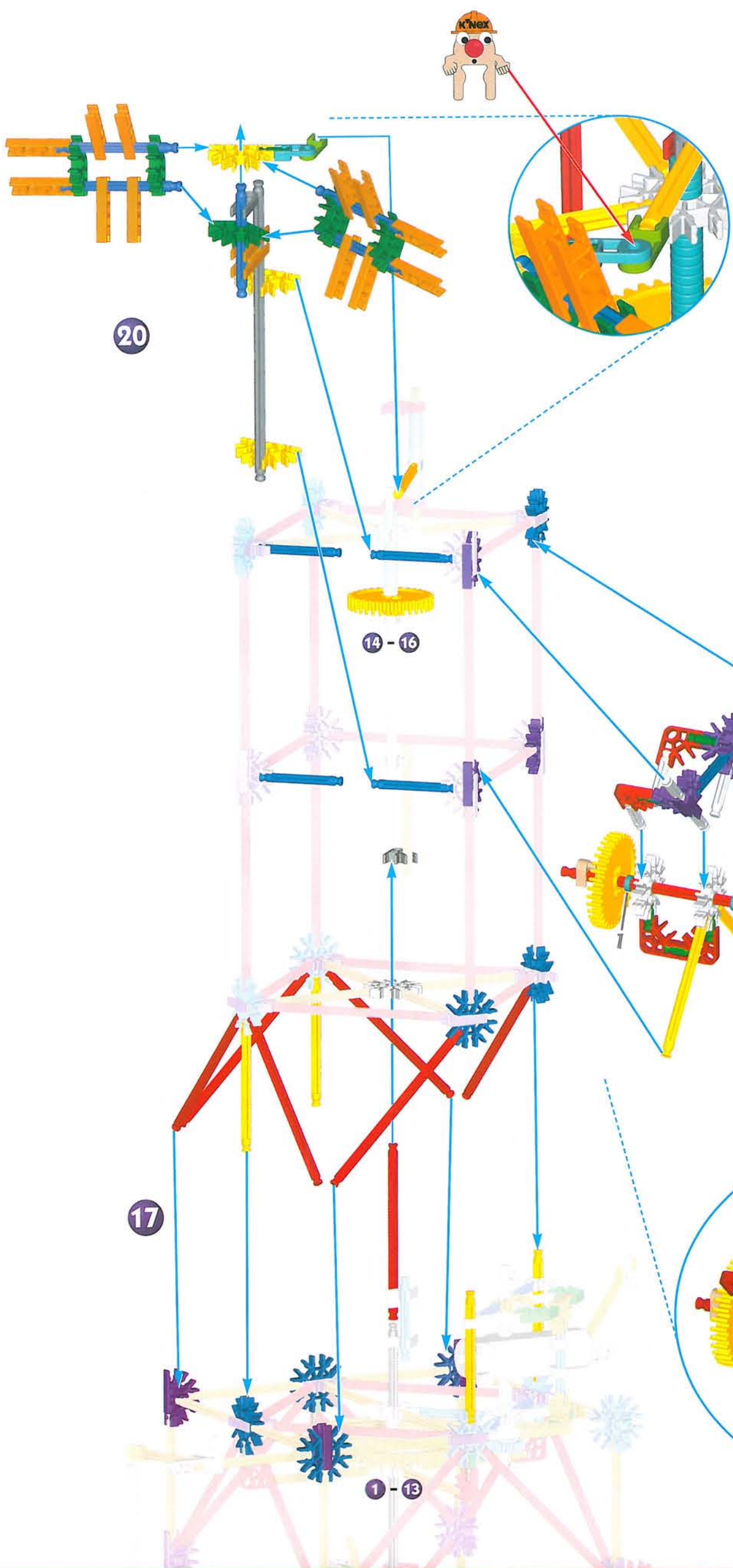

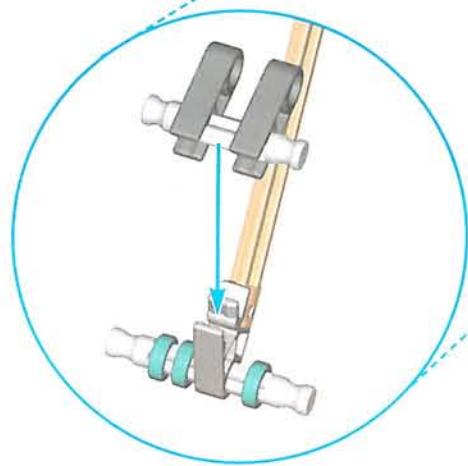
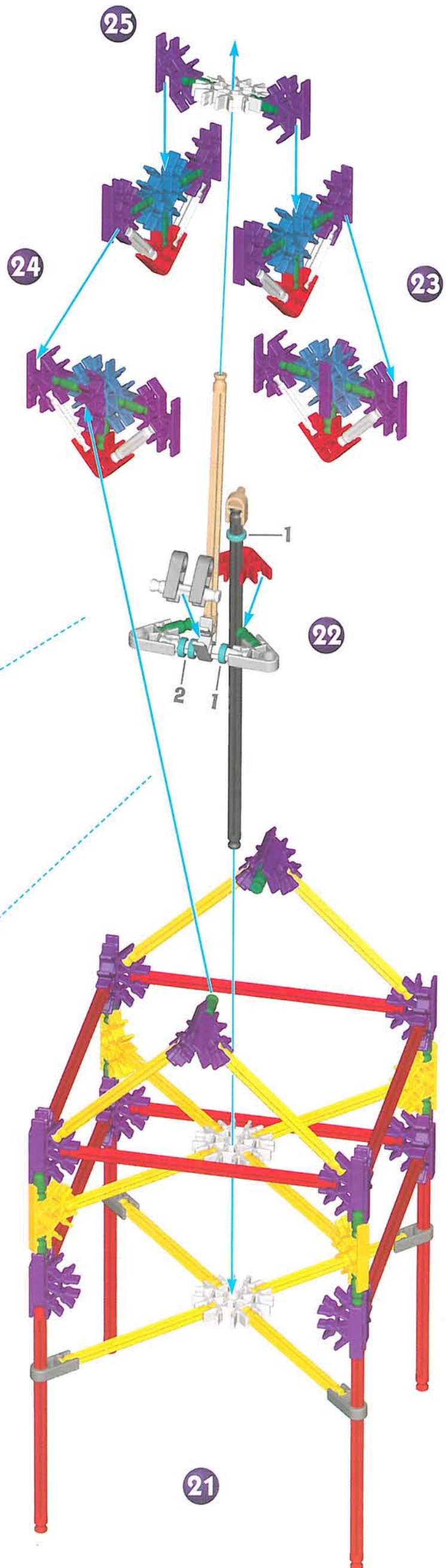
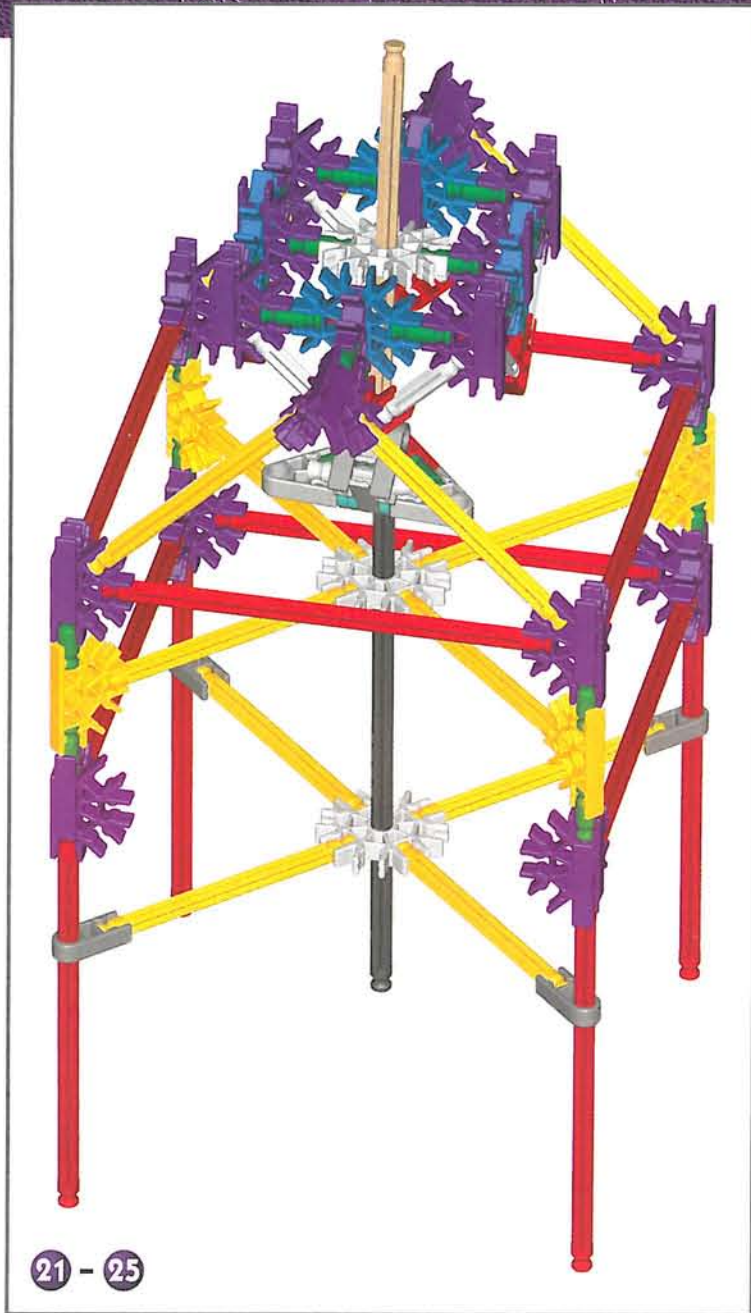

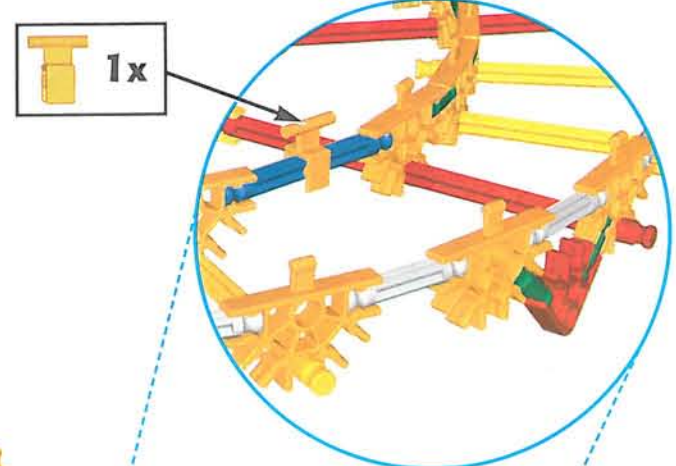
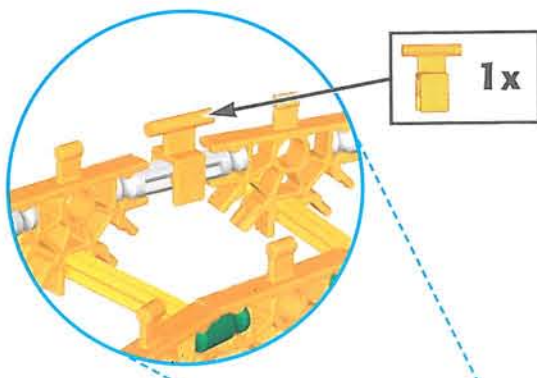

28

29

27



6

21 - 25

26

1 - 20

30

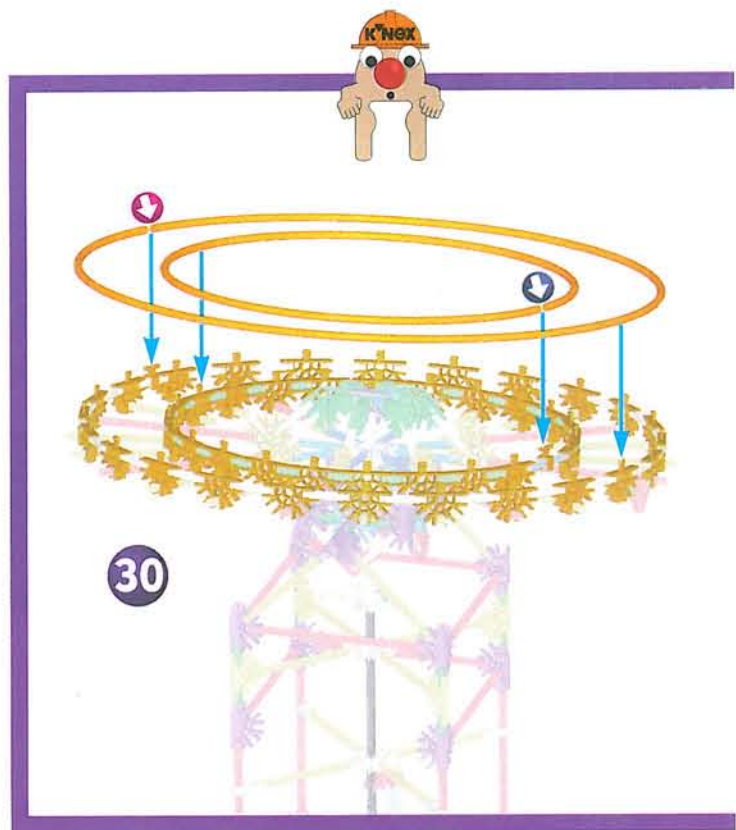
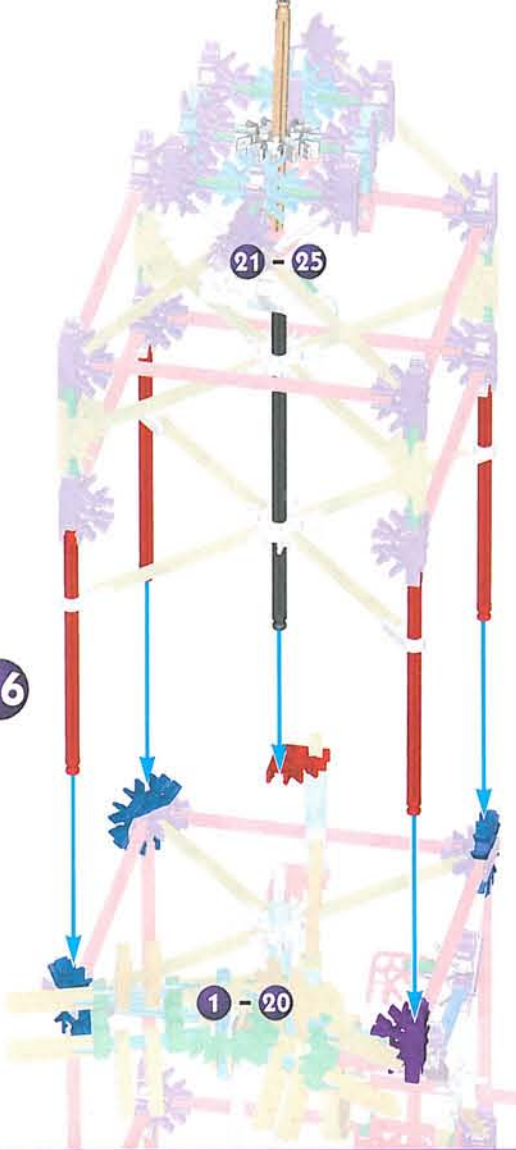
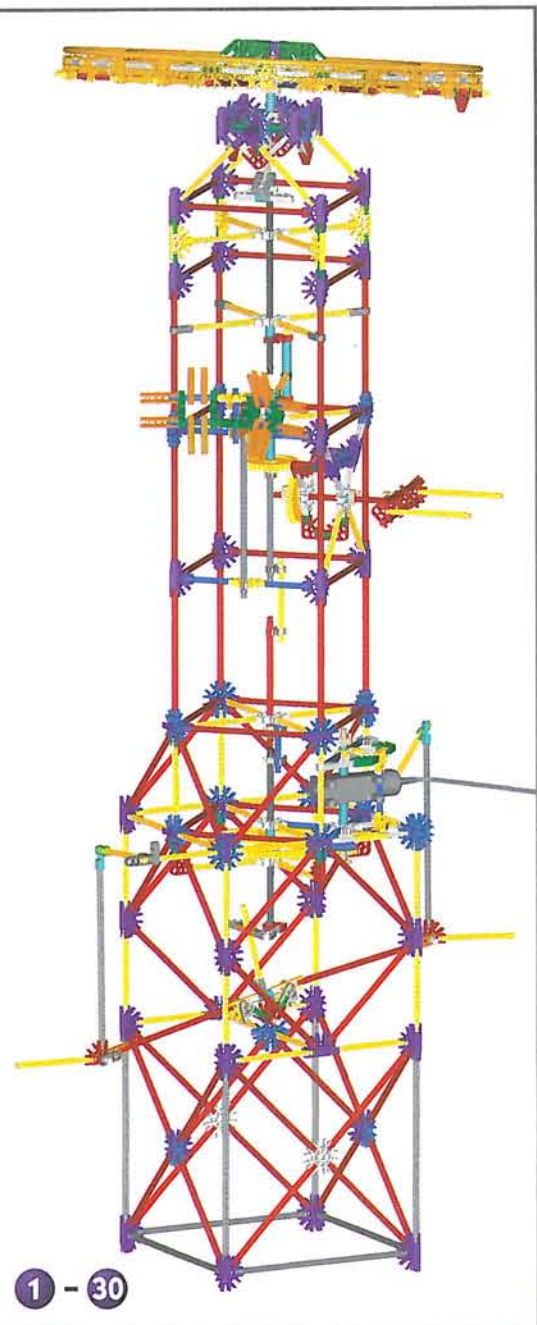

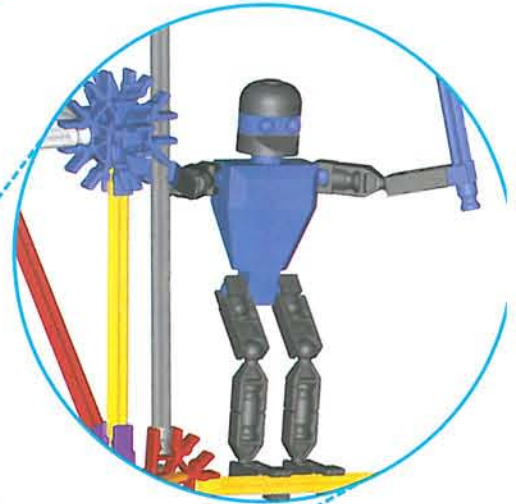
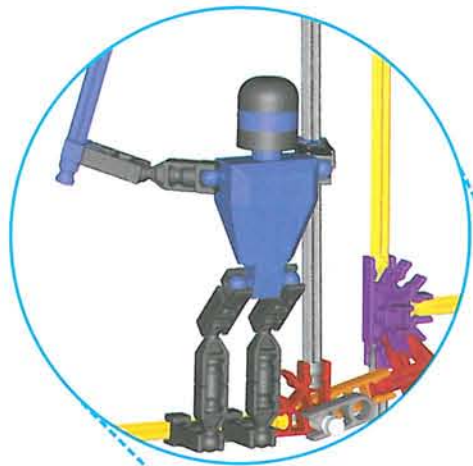
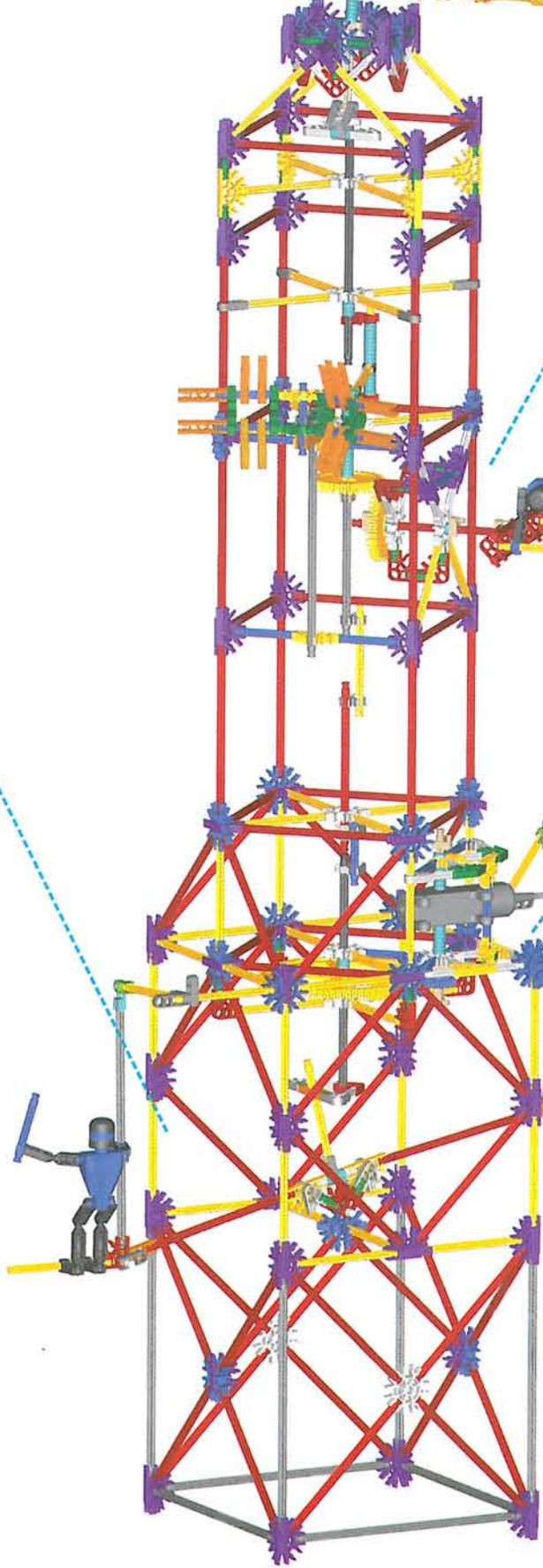
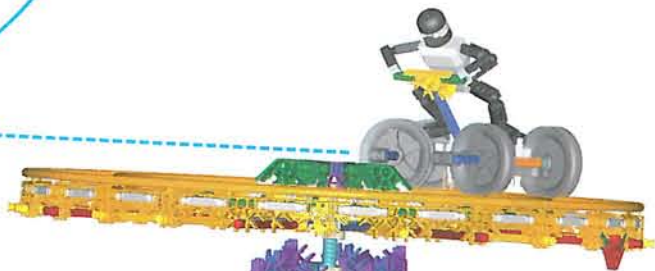
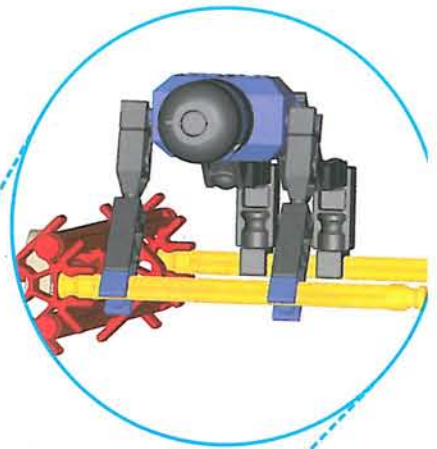
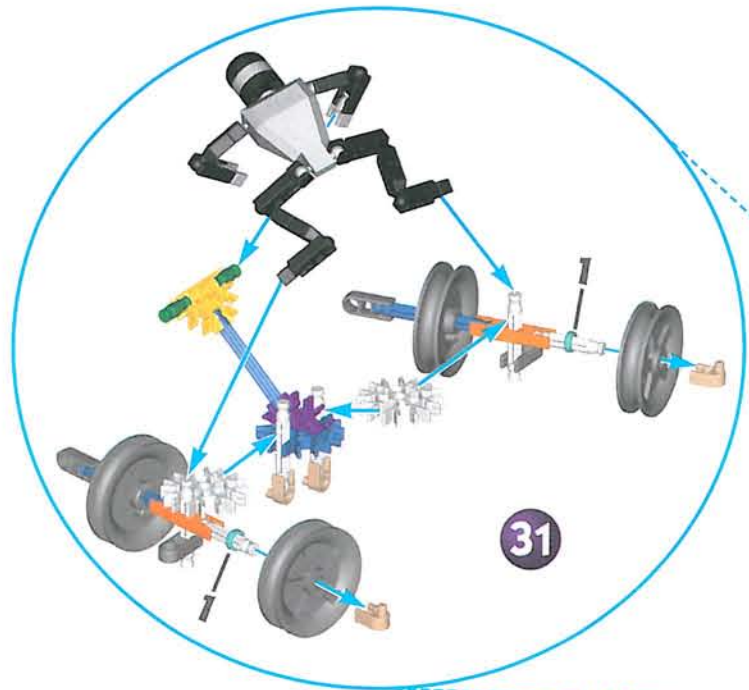

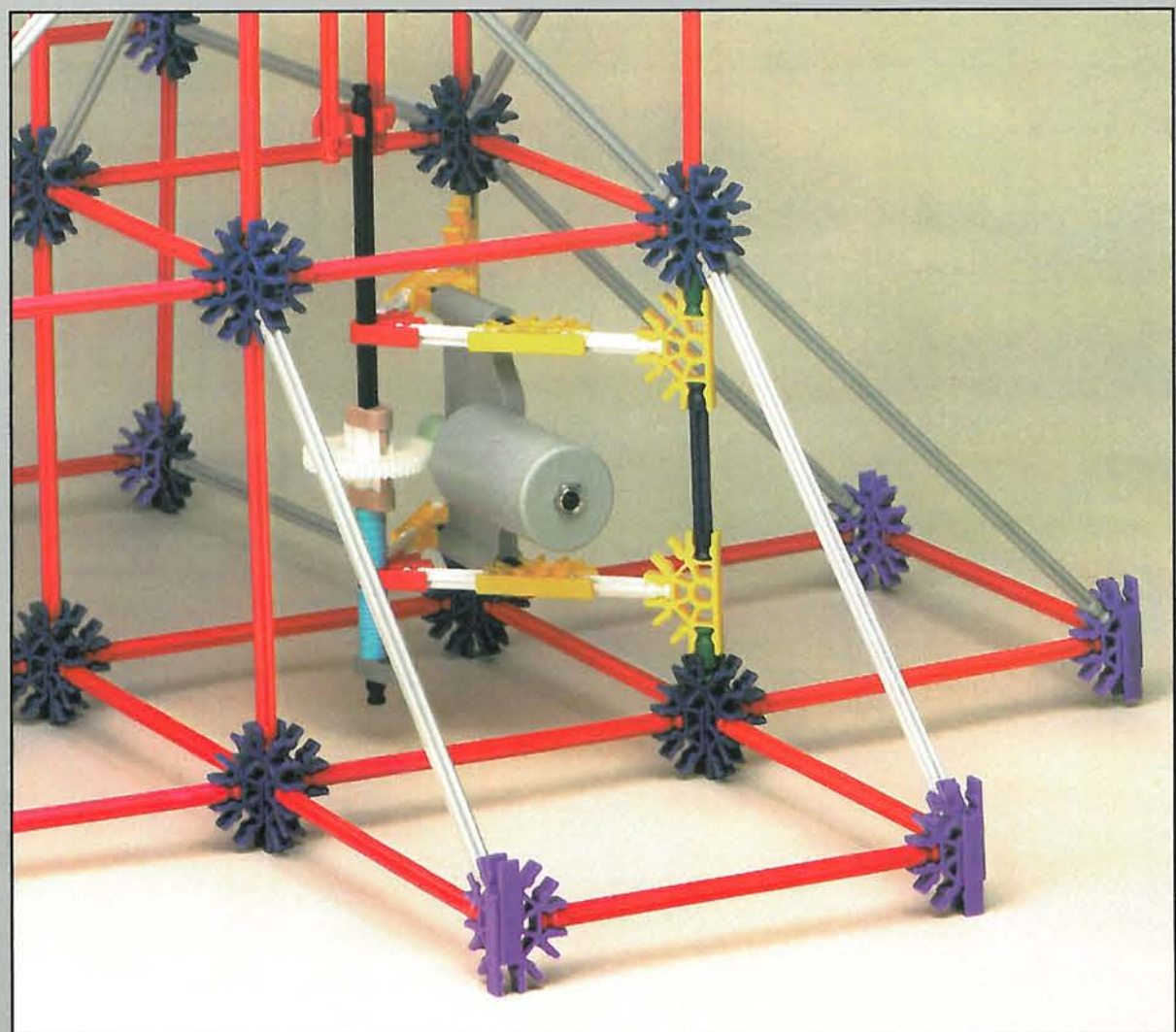
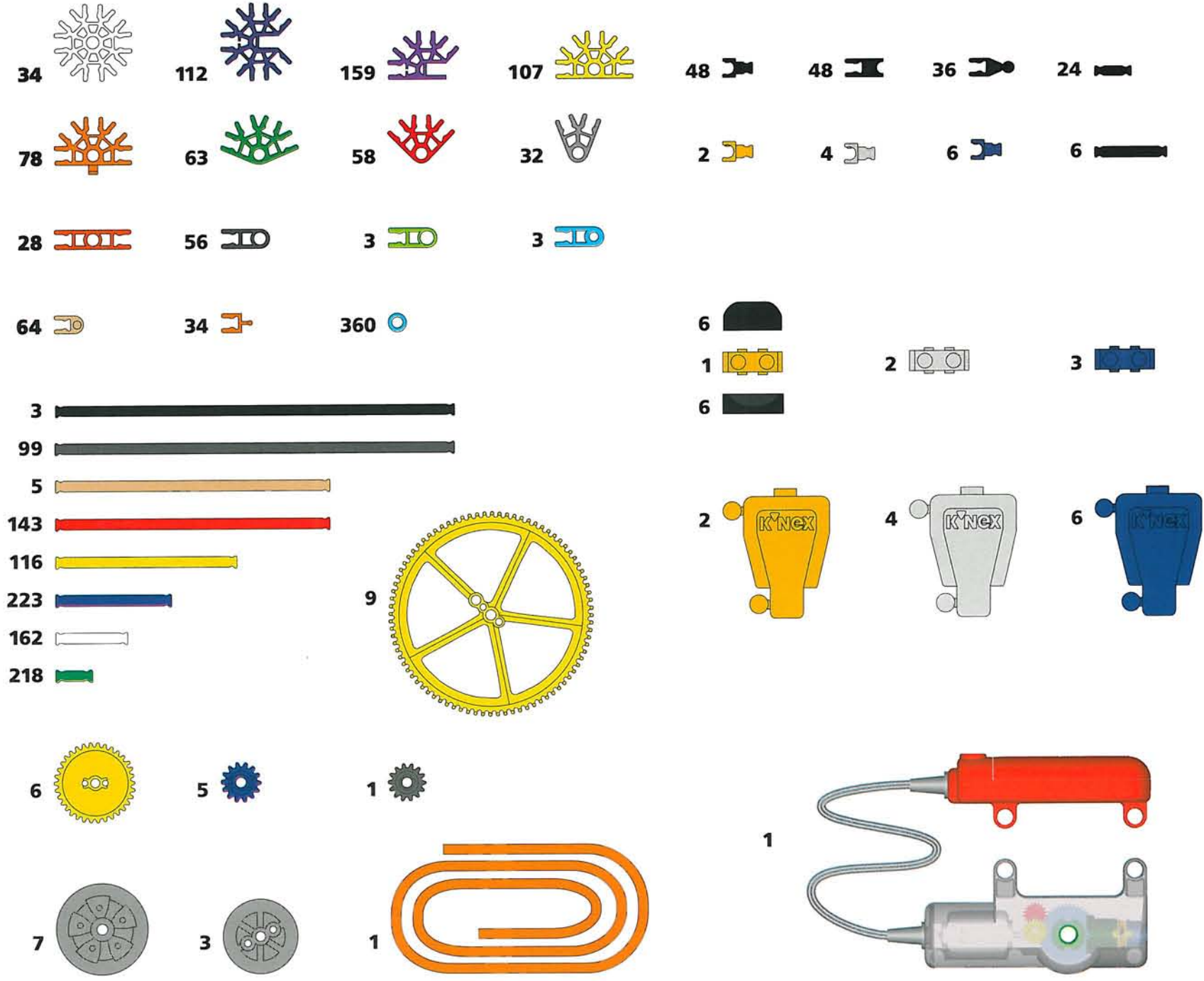

- USA (GB)** K'NEX Motor sold separately. 80011 (48011/48013)
- F** Moteur K'NEX vendu séparément.
- I** Motore K'NEX venduto separatamente.
- D** Der K'NEX-Motor wird separat verkauft.
- E** El motor K'NEX se vende por separado.
- S** K'NEX-motorn säljes separat.
- DK** K'NEX motor solgt særskilt.
- N** K'NEX-motoren selges separat.
- SF** K'NEX-moottori myydään erikseen.
- NL** De K'NEX-motor wordt afzonderlijk geleverd.
- P** Motor K'NEX, vendido separadamente.
- G** Η μηχανή K'NEX πωλείται ξεχωριστά.
- TR** K'NEX Motoru ayrı olarak satılır.
- J** K'NEXモーターは別売りです。
- CHI** K'NEX 馬達分開出售
- IL** המנוע של K'nex נמכר בנפרד.



Back View
Vue de dos
Vista dal retro
Ansicht von hinten
Vista posterior
Bakifrån
Set bagfra
Bakfra
Takaa
Achteraanzicht
Vista posterior
Πίσω όψη
Arkadan görünüşü
後ろから見た図
背部圖景
תצוגה אחורית