

55

 x7



x23

56

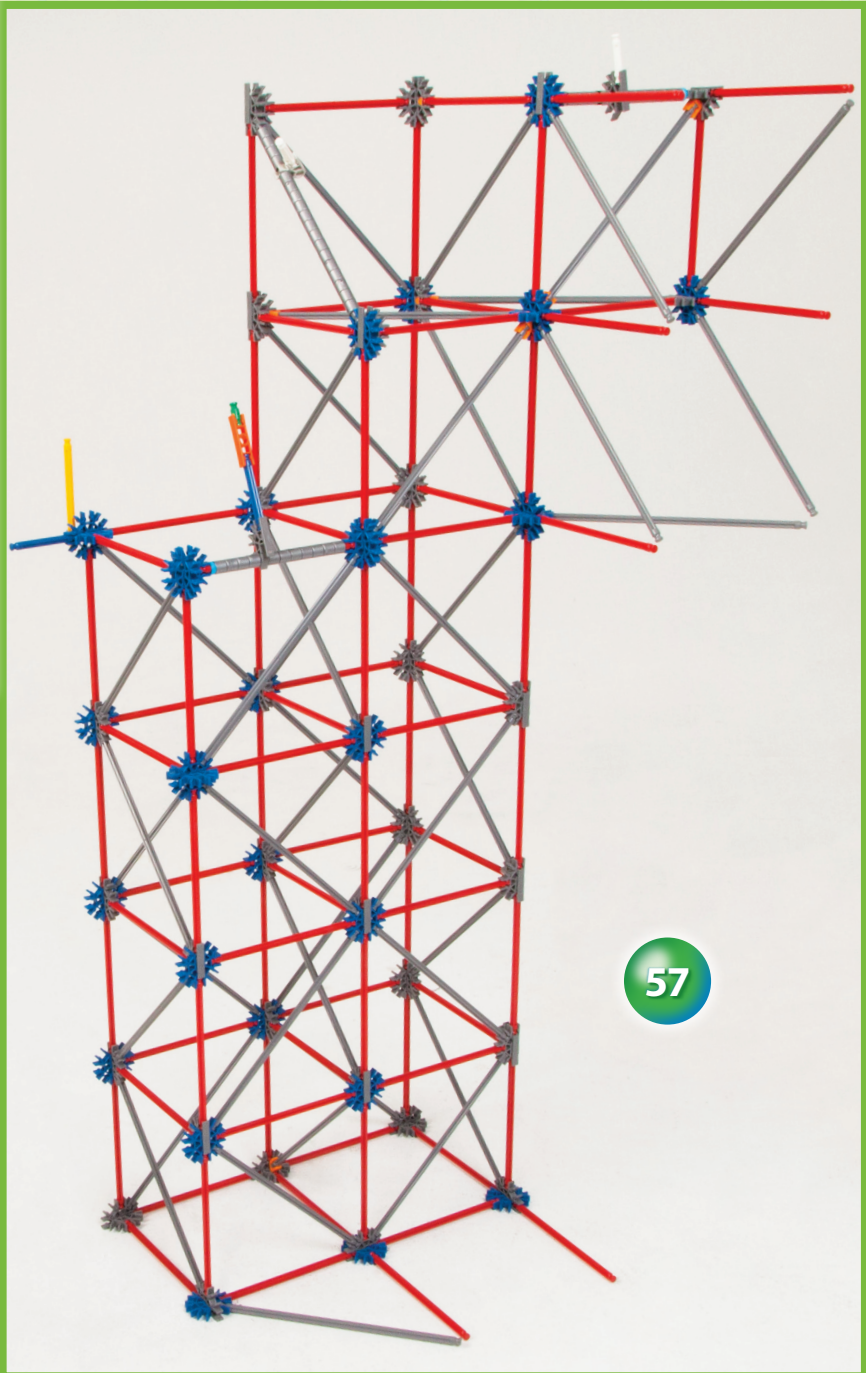
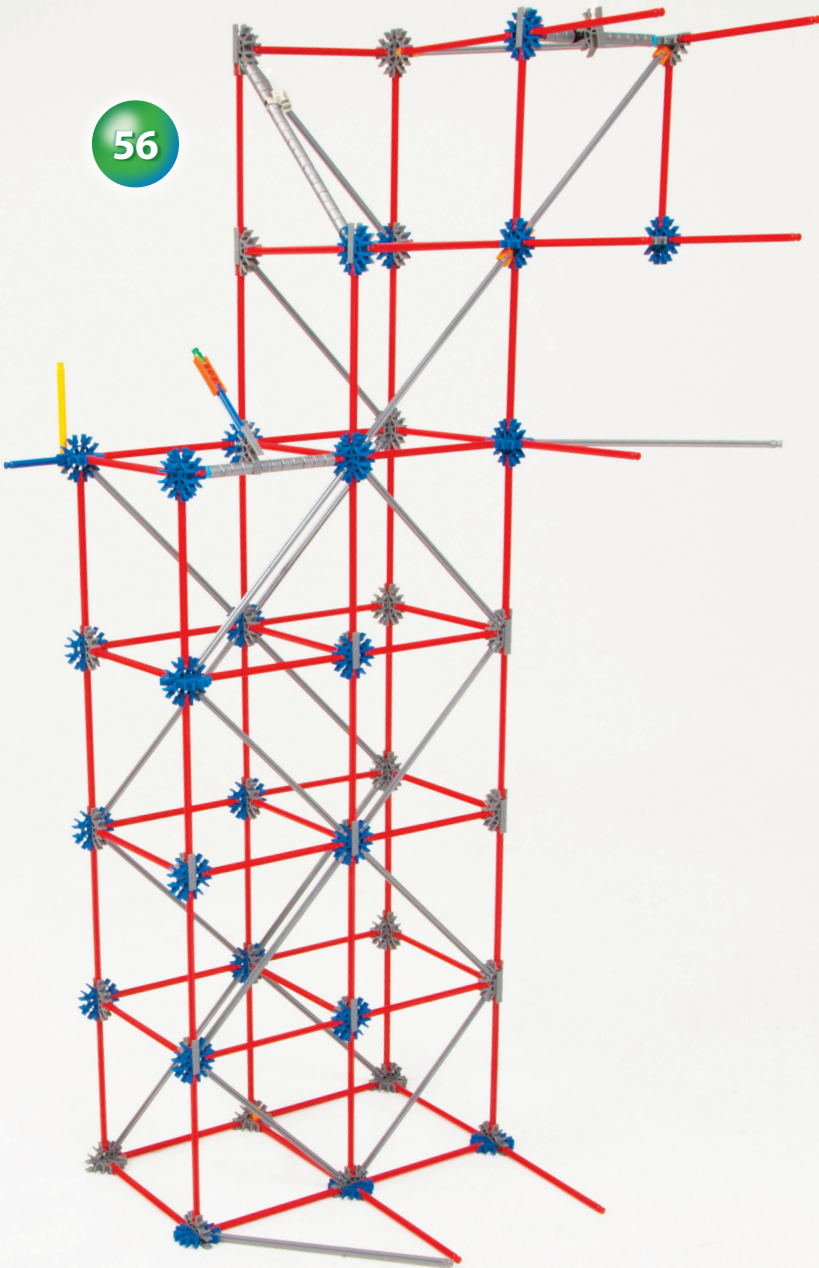

57

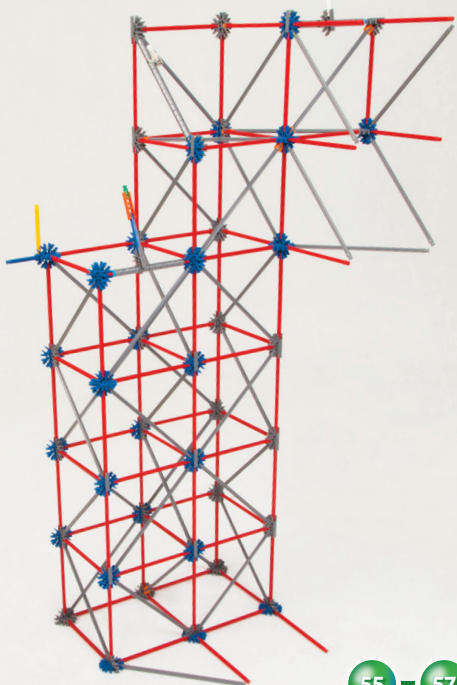

55 - 57



x21

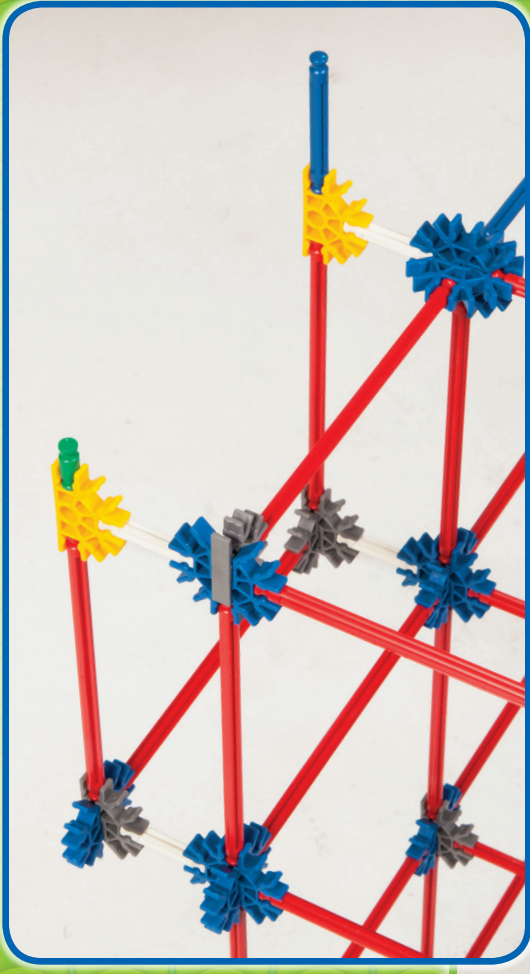

58

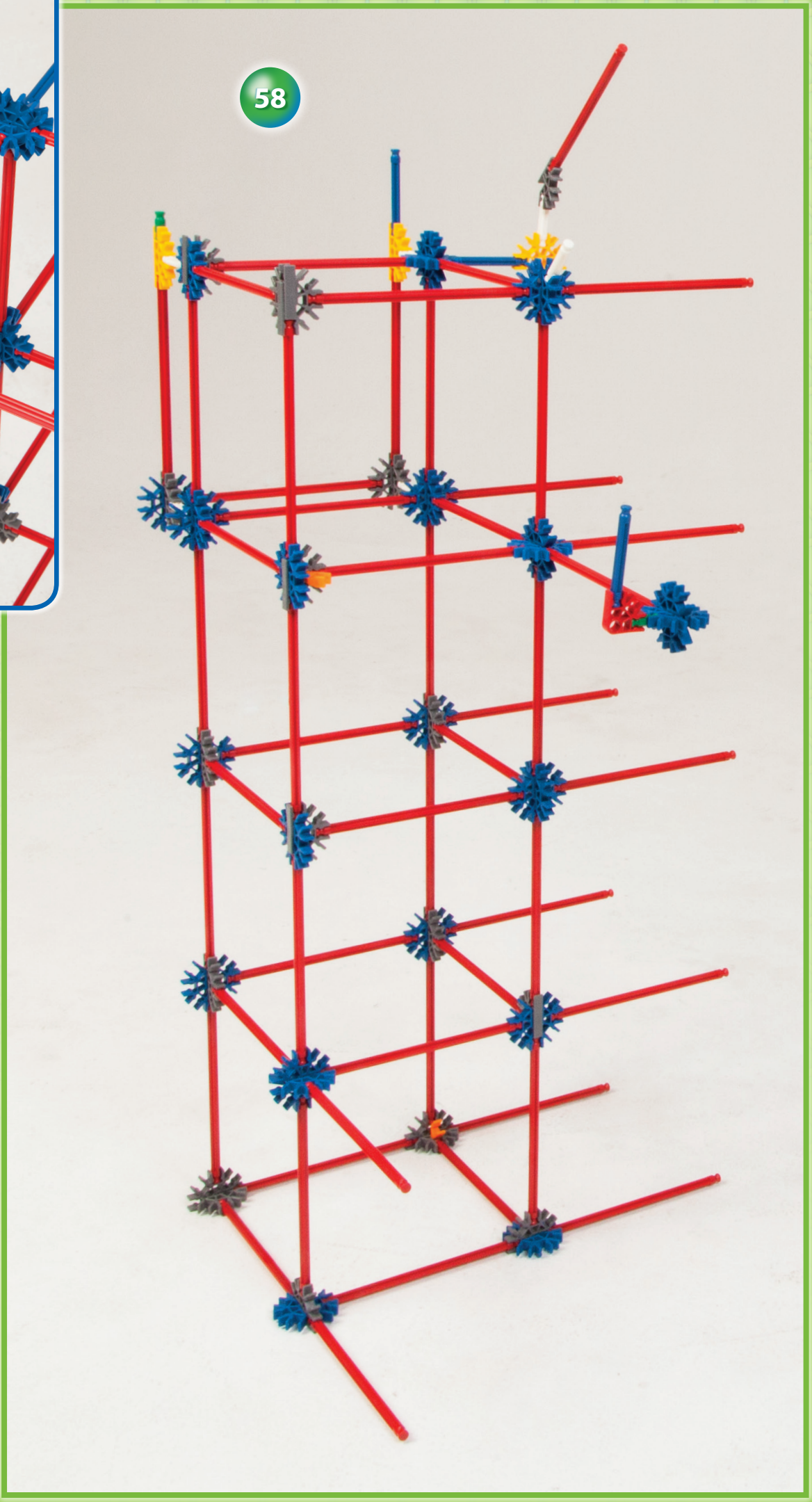



x20

59

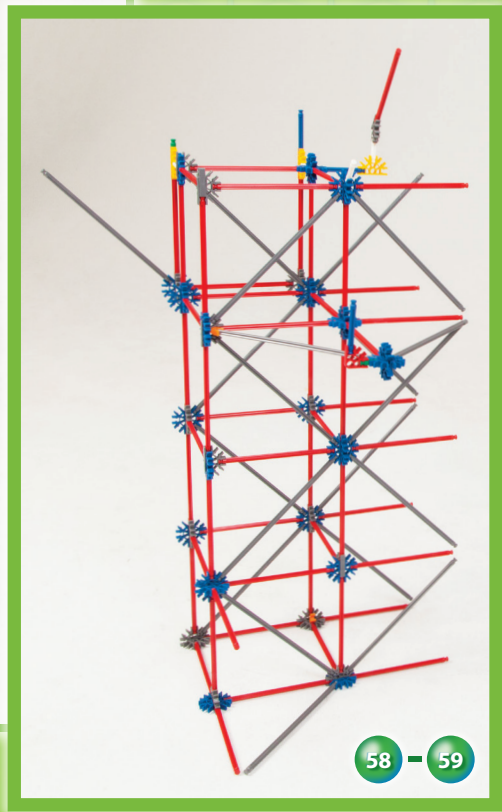
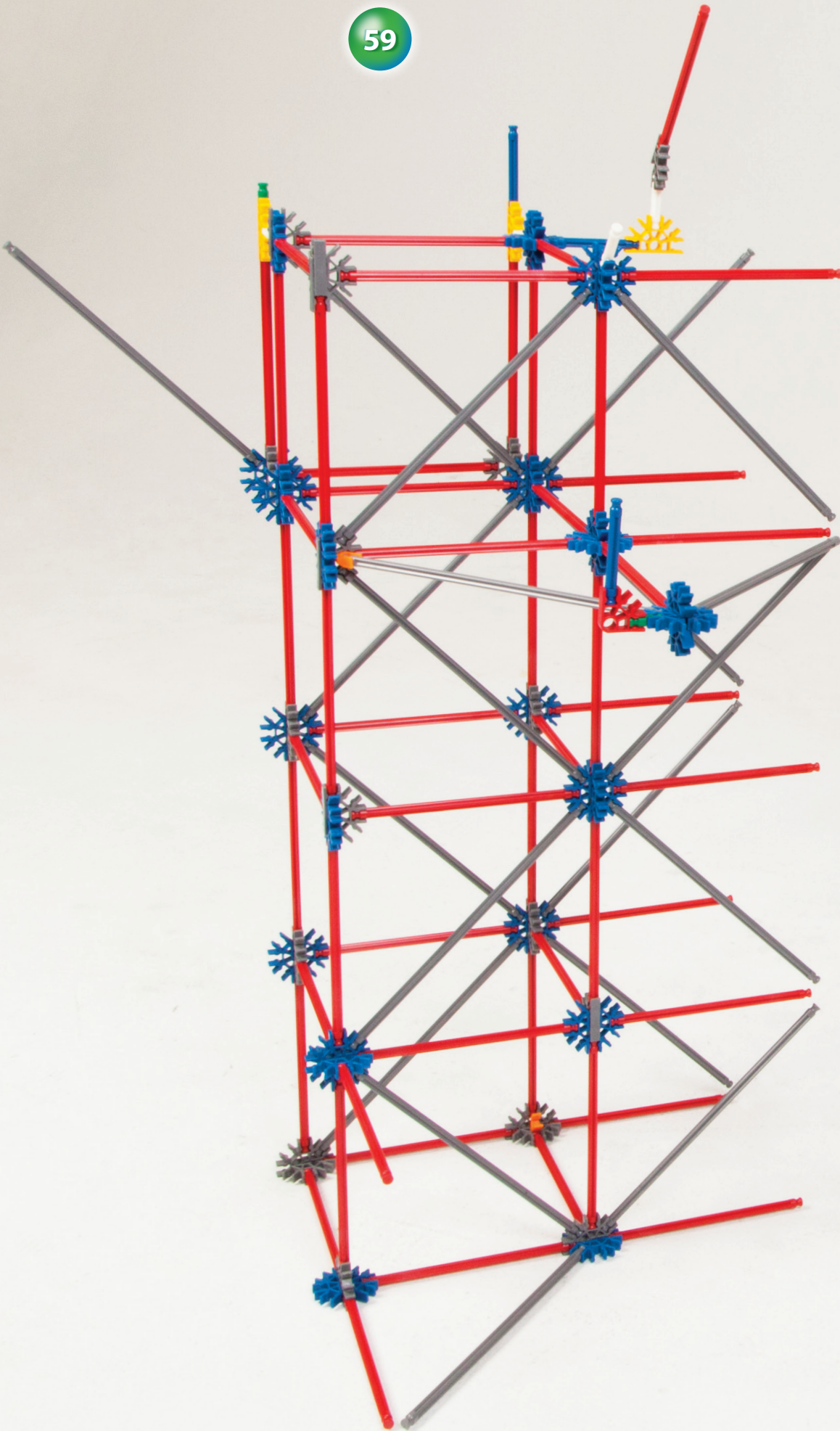

58 - 59



x11

60

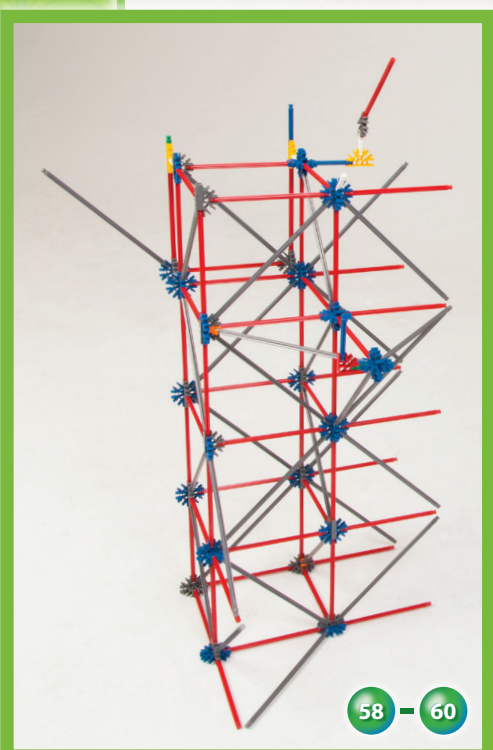
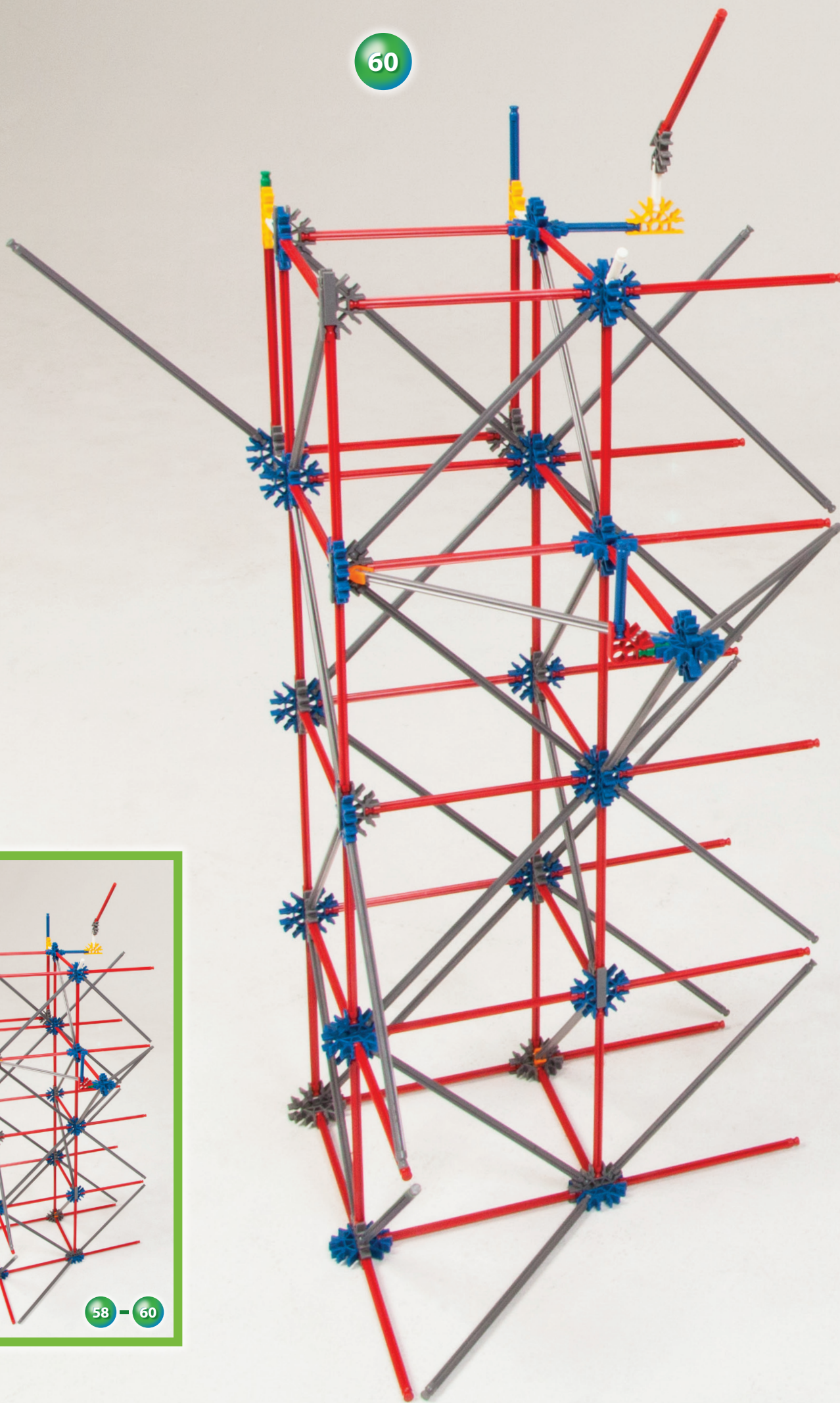

58 - 60

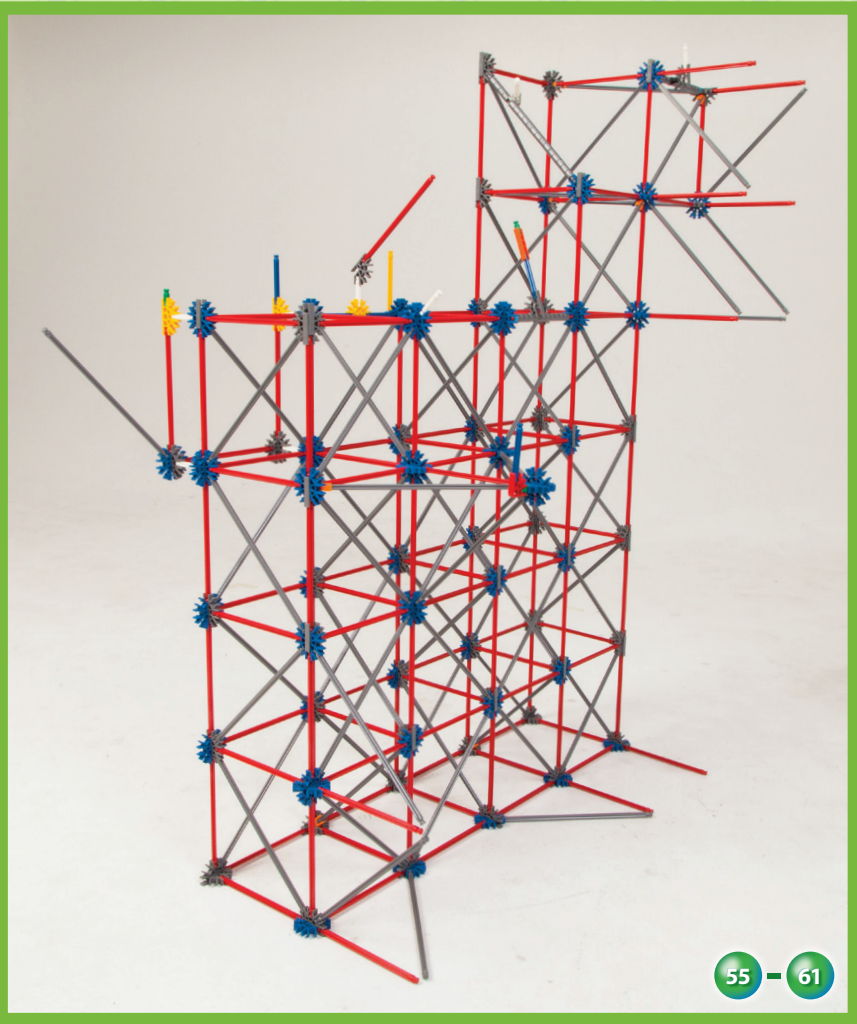

55 - 61

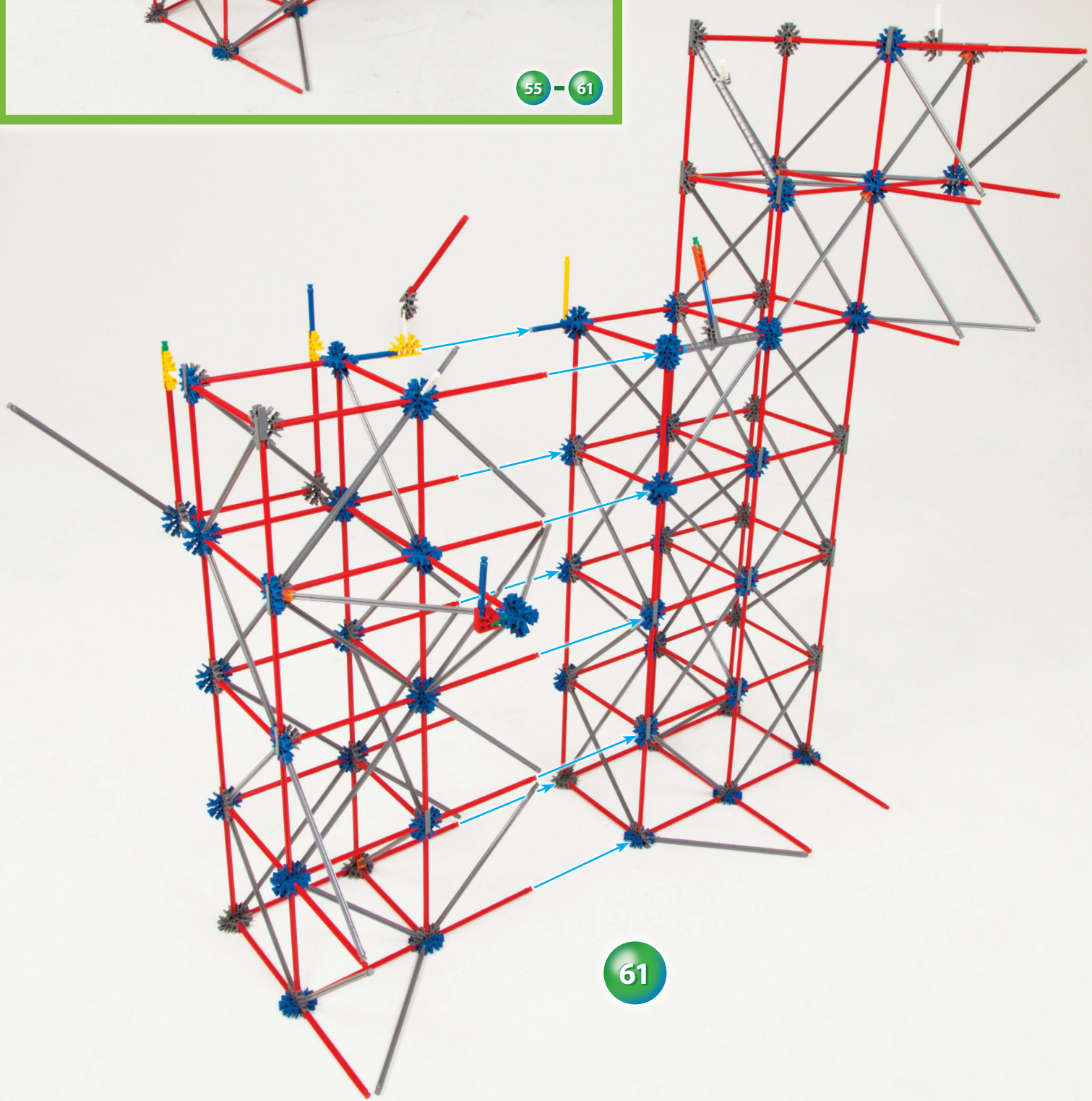

61

Push the connector onto the plastic pins (1). To attach the metal adapter align the first set screw (2) with the flat side (3) of the motor shaft and push together. Then tighten the set screw.

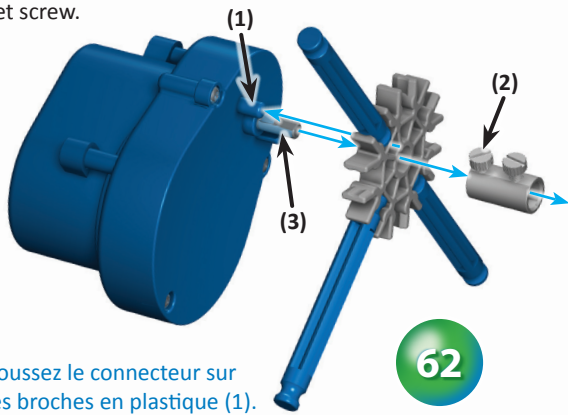

62

Poussez le connecteur sur les broches en plastique (1). Pour attacher l'adaptateur métallique alignez la première vis de réglage (2) avec le côté plat (3) de l'arbre du moteur et poussez ensemble. Puis serrer la vis de réglage.

Push black rod (1) fully into coupler (2). Tighten set screw with a screwdriver. Be sure to push the 2 tan connectors into the holes of the red gears (3).

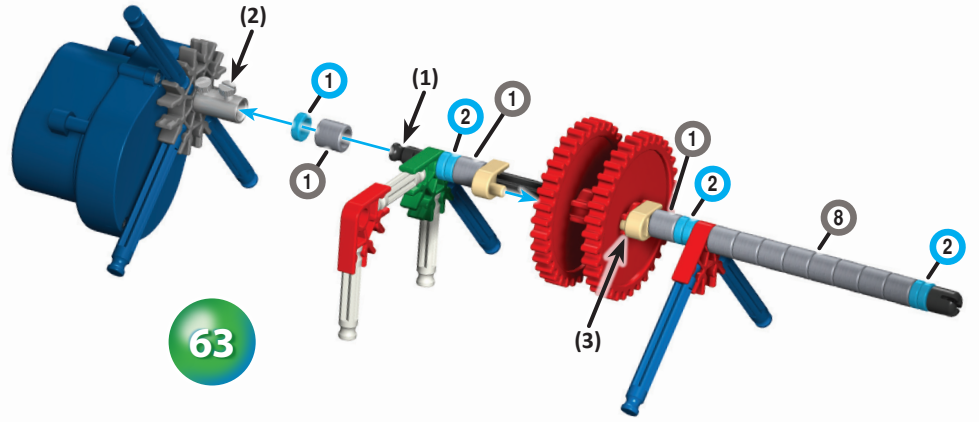

63

Poussez la tige noire(1) pleinement dans le coupleur(2). Serrer la vis de réglage avec un tournevis. Assurez-vous de pousser les 2 connecteurs tan dans les trous du pignons rouge (3).

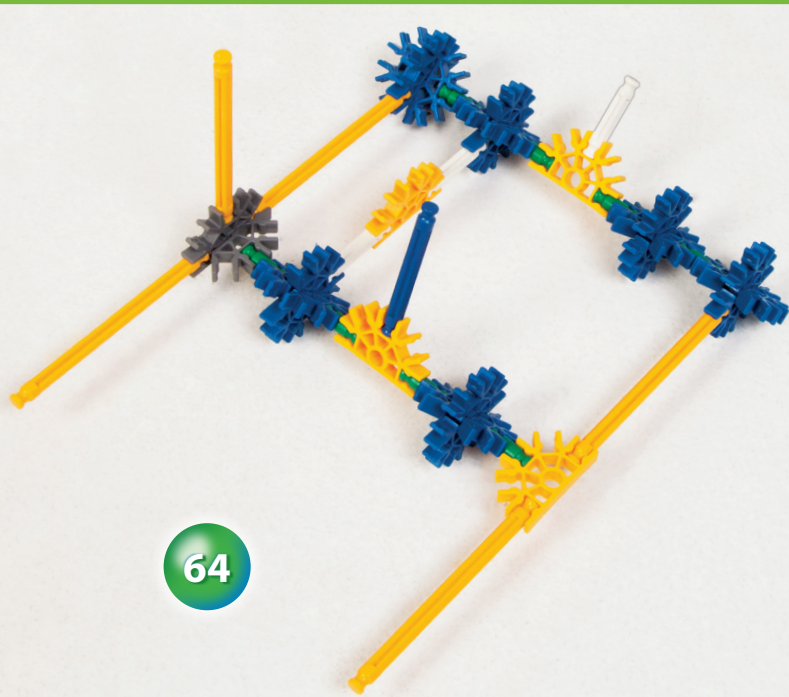

64

(Designer note: The gray motor in this shot was a proto-type that we used, while the new blue motor was still being engineered.)

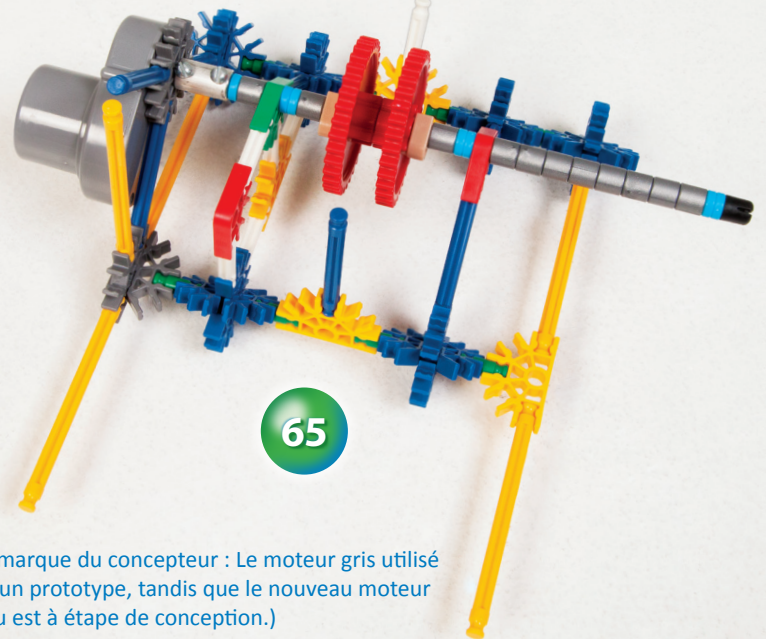

65

(Remarque du concepteur : Le moteur gris utilisé est un prototype, tandis que le nouveau moteur bleu est à étape de conception.)



66

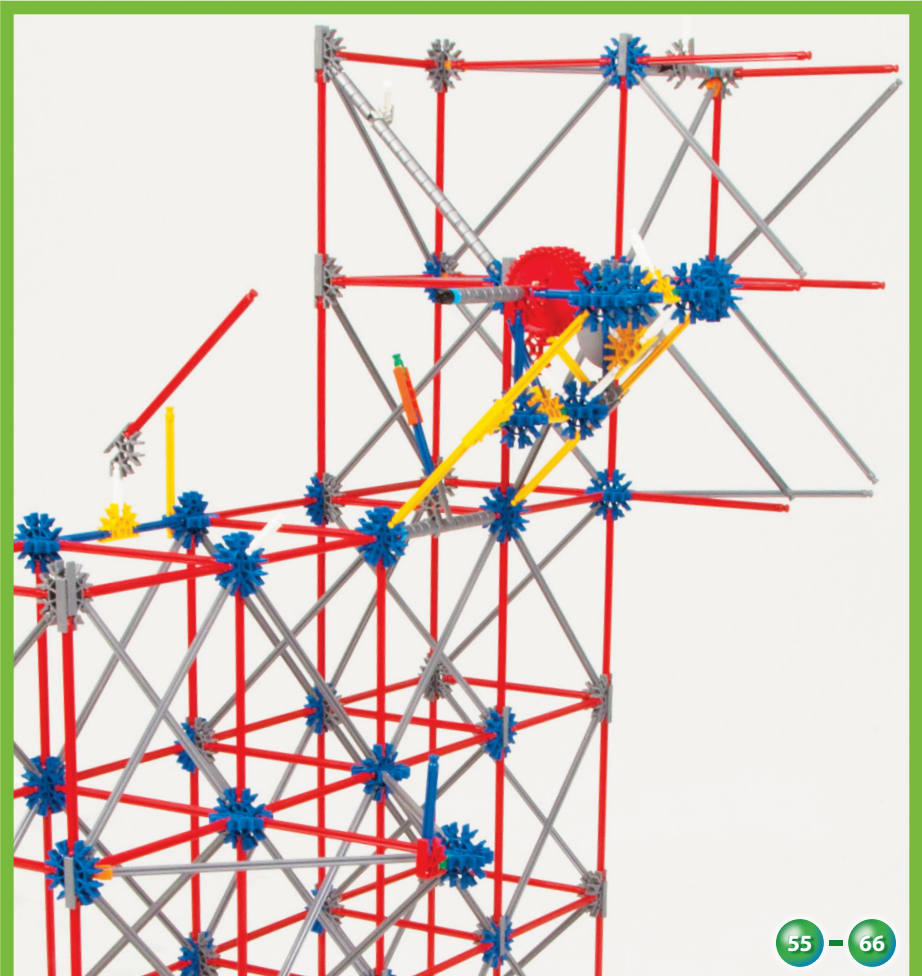

55 - 66



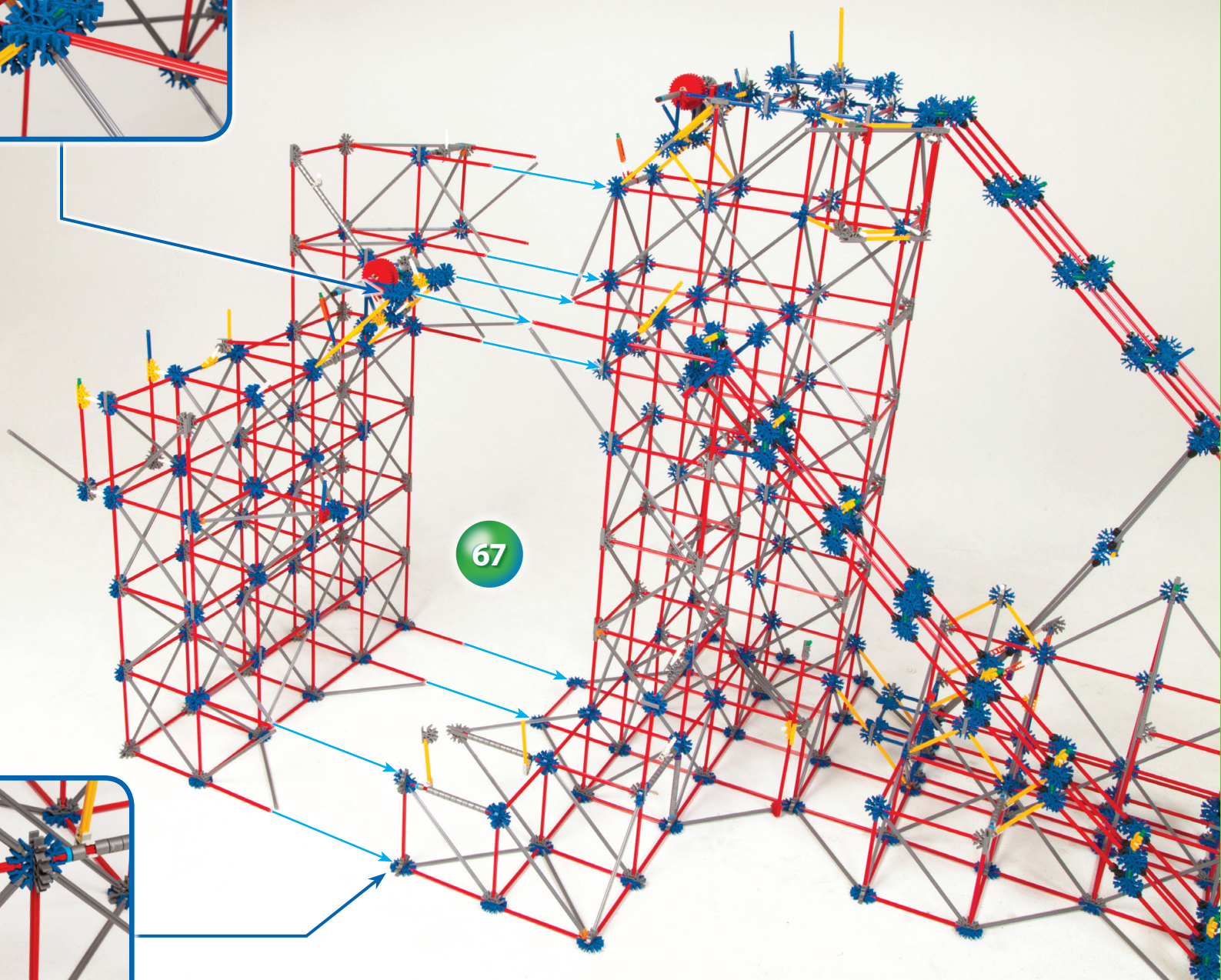
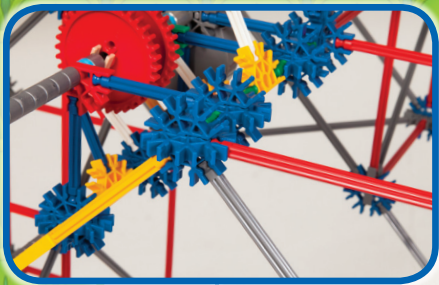

67

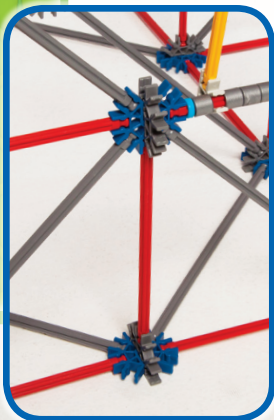

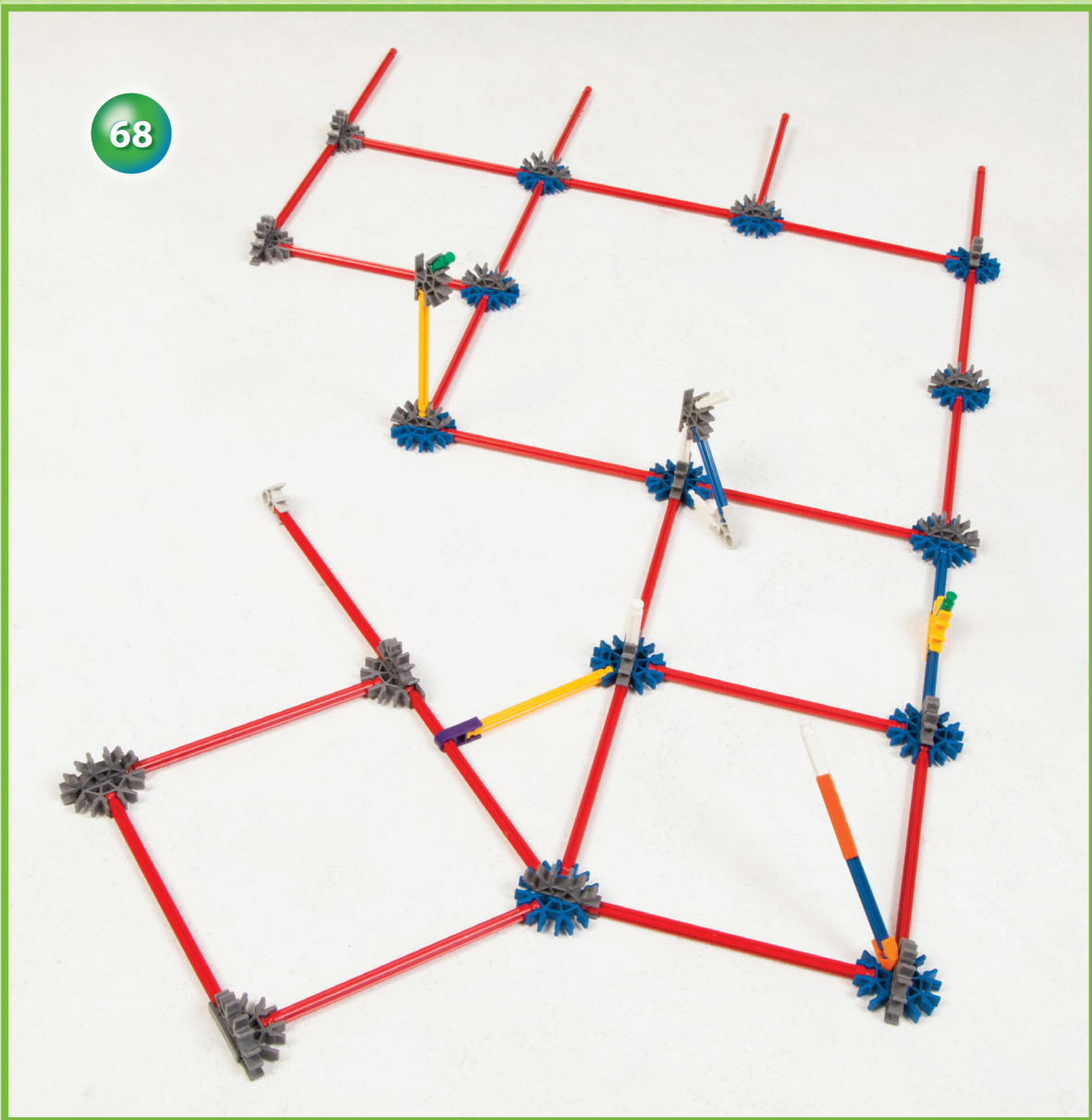

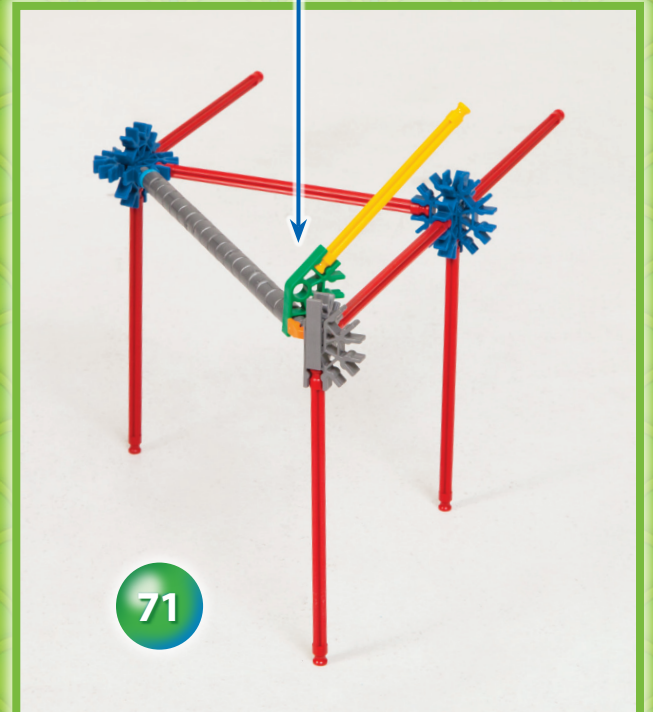
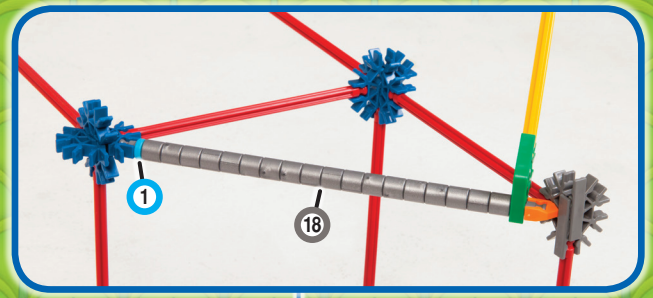
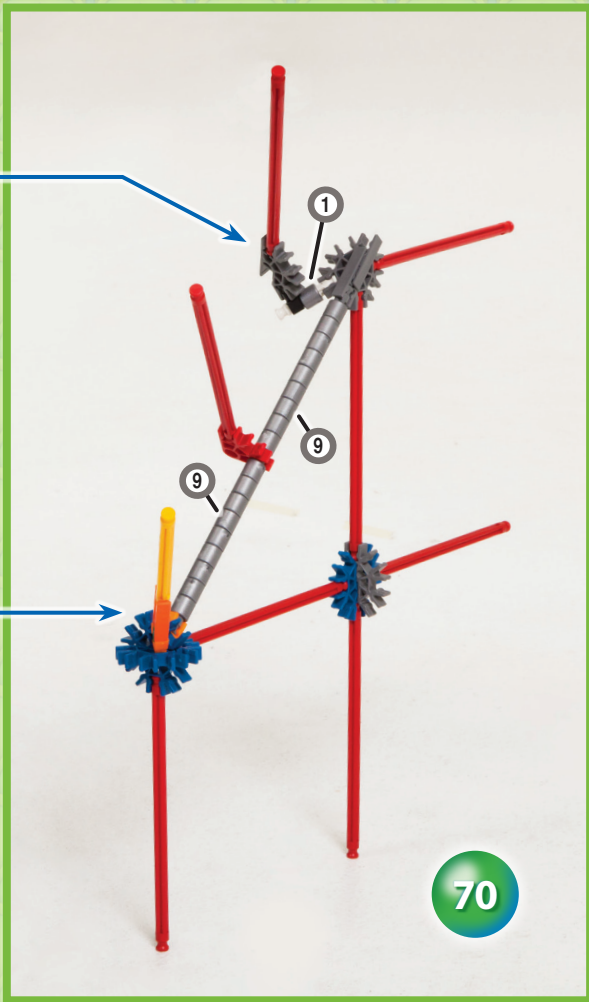
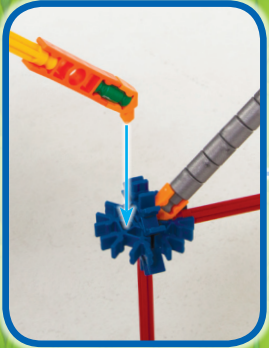
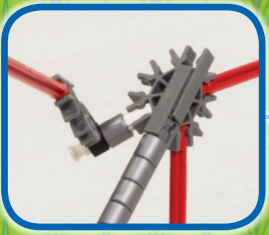



x10

72



68 72



x18

73

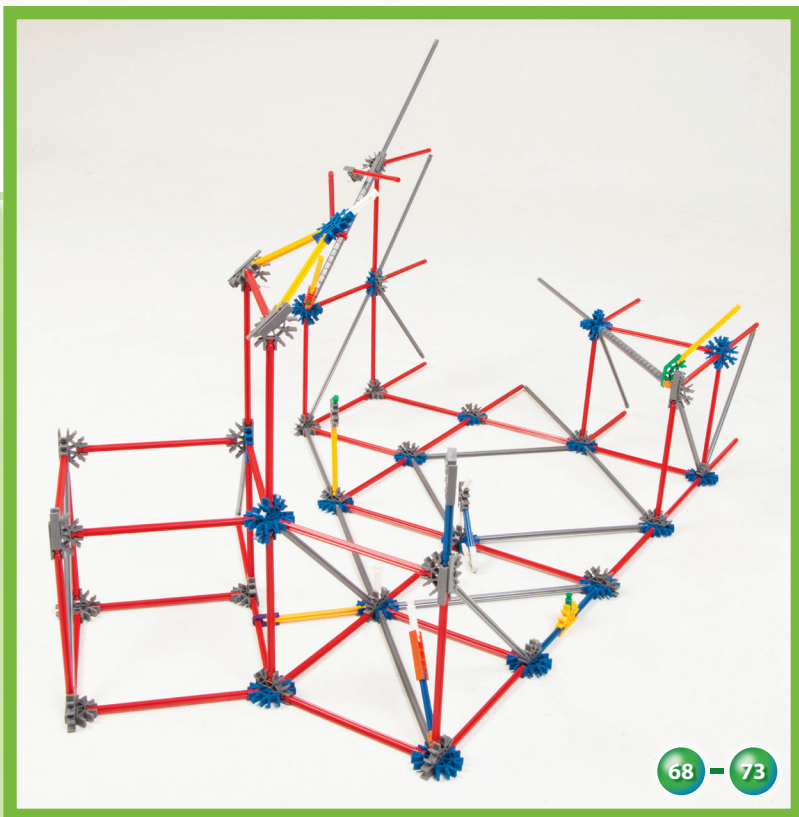
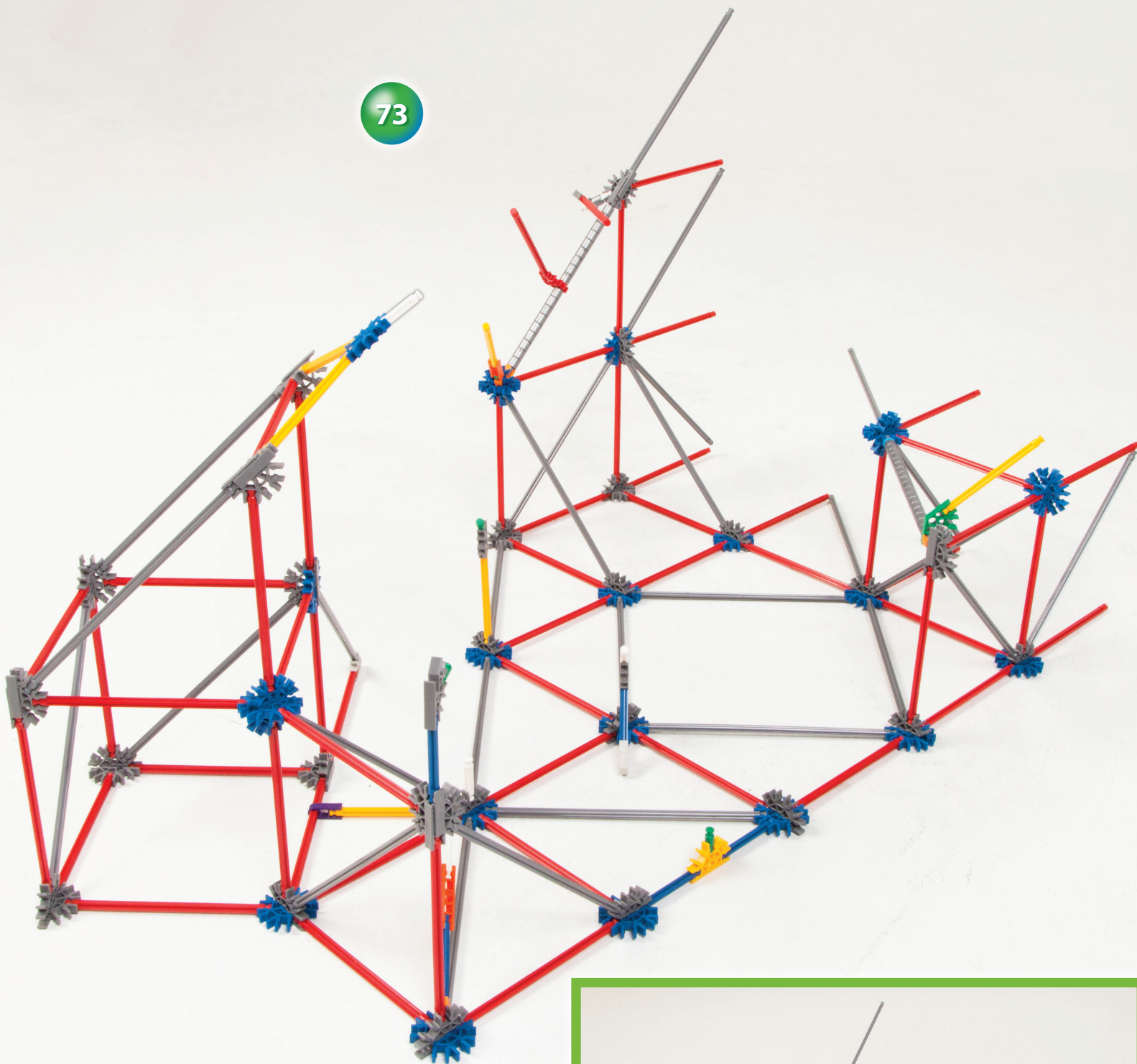

68 - 73



74

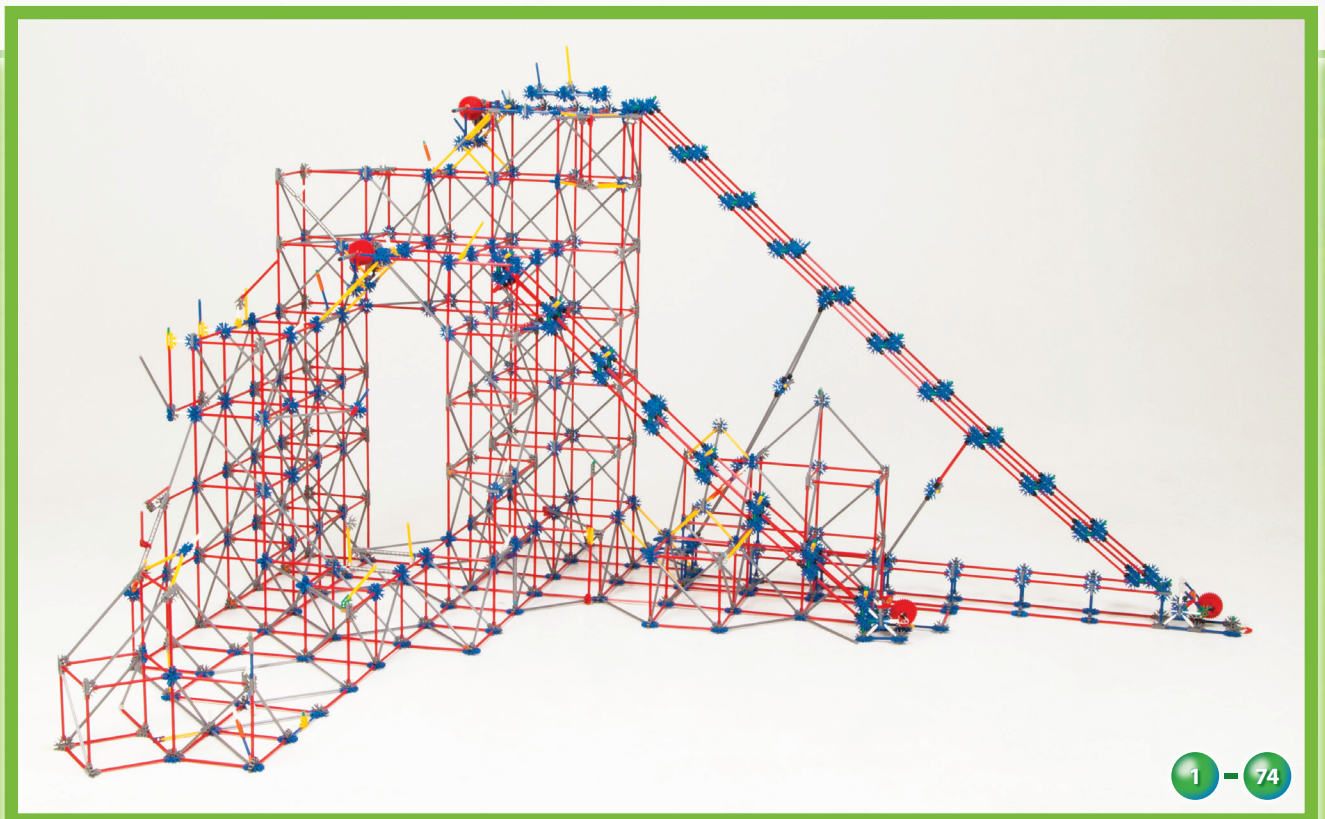

1 - 74

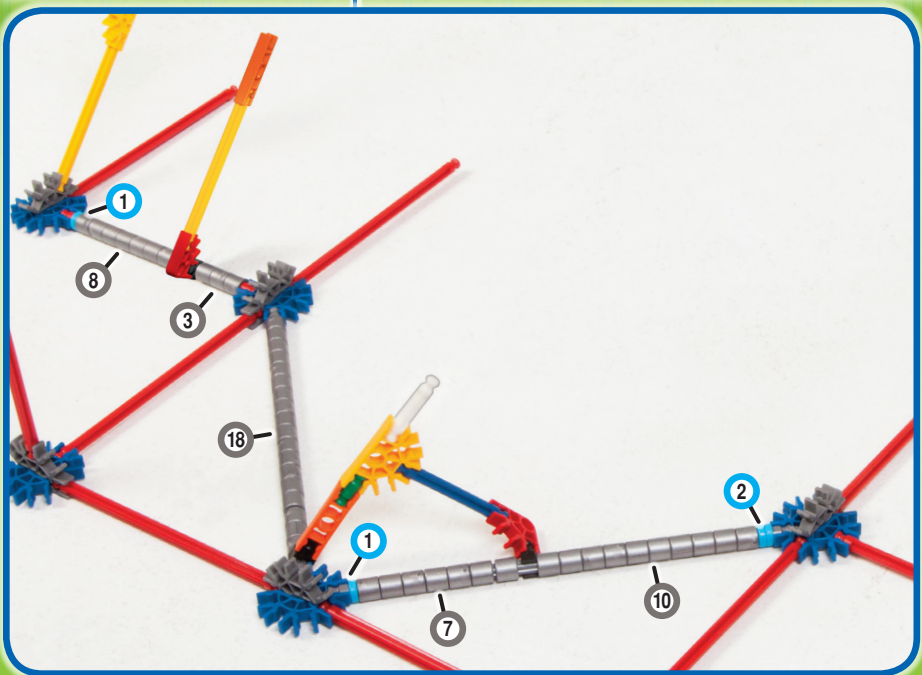
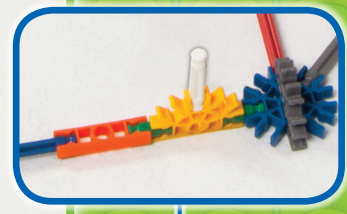
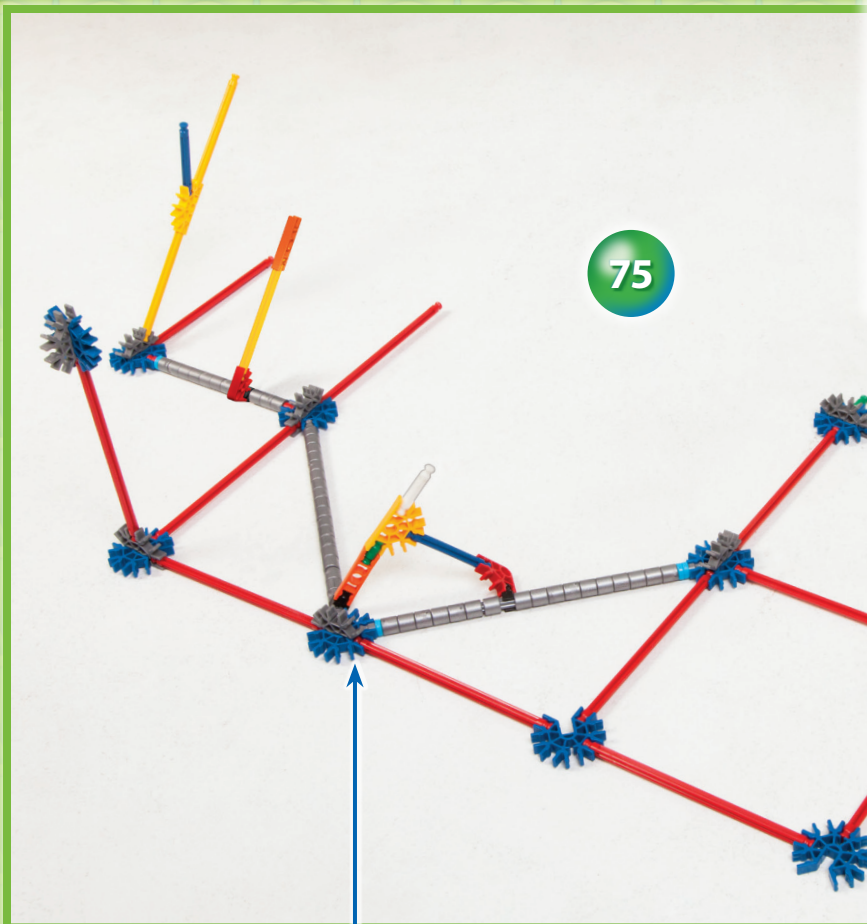
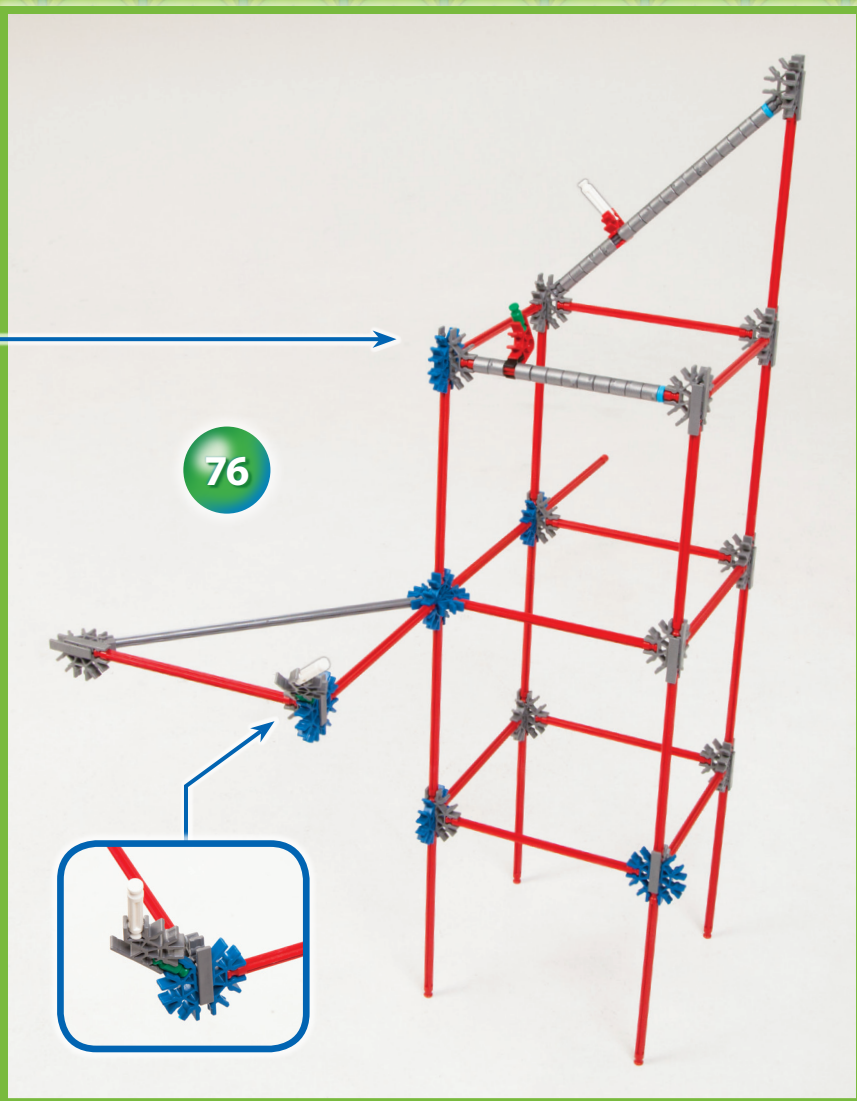
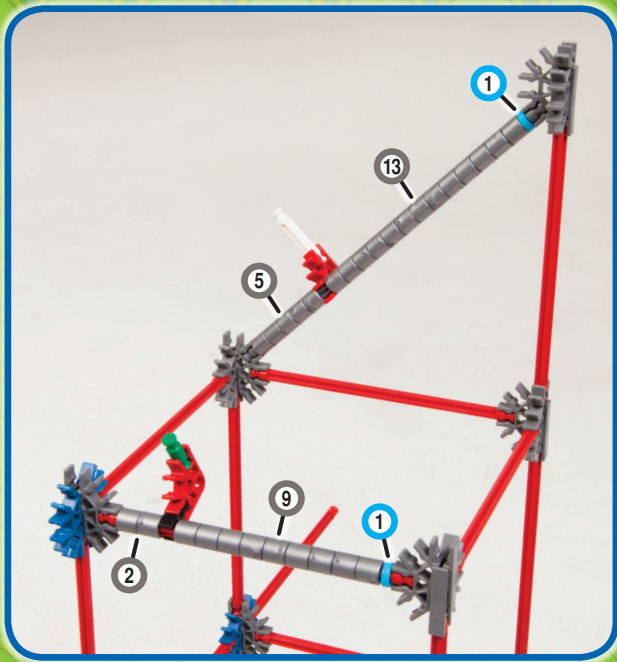



x16

77

78

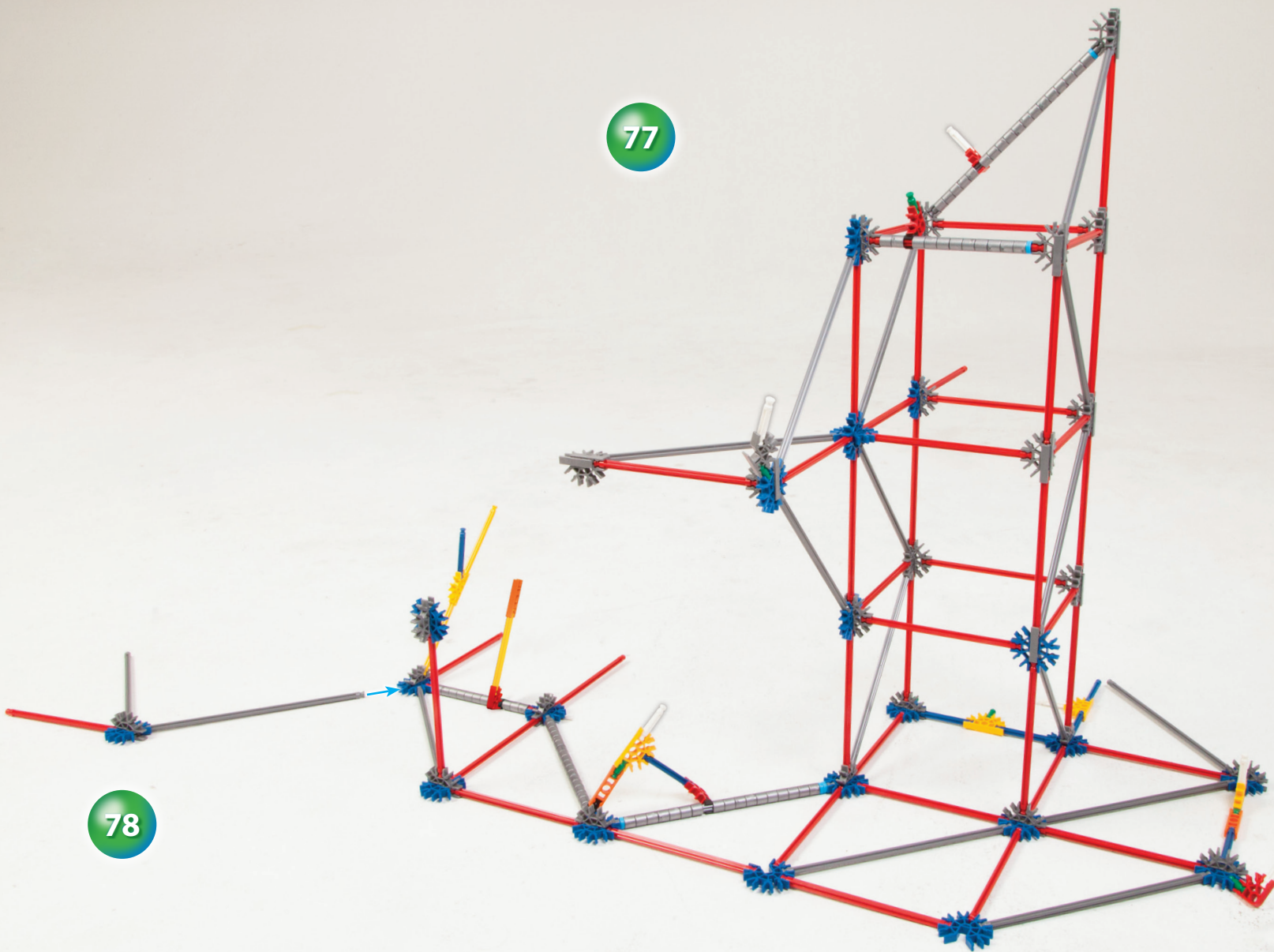

75

78

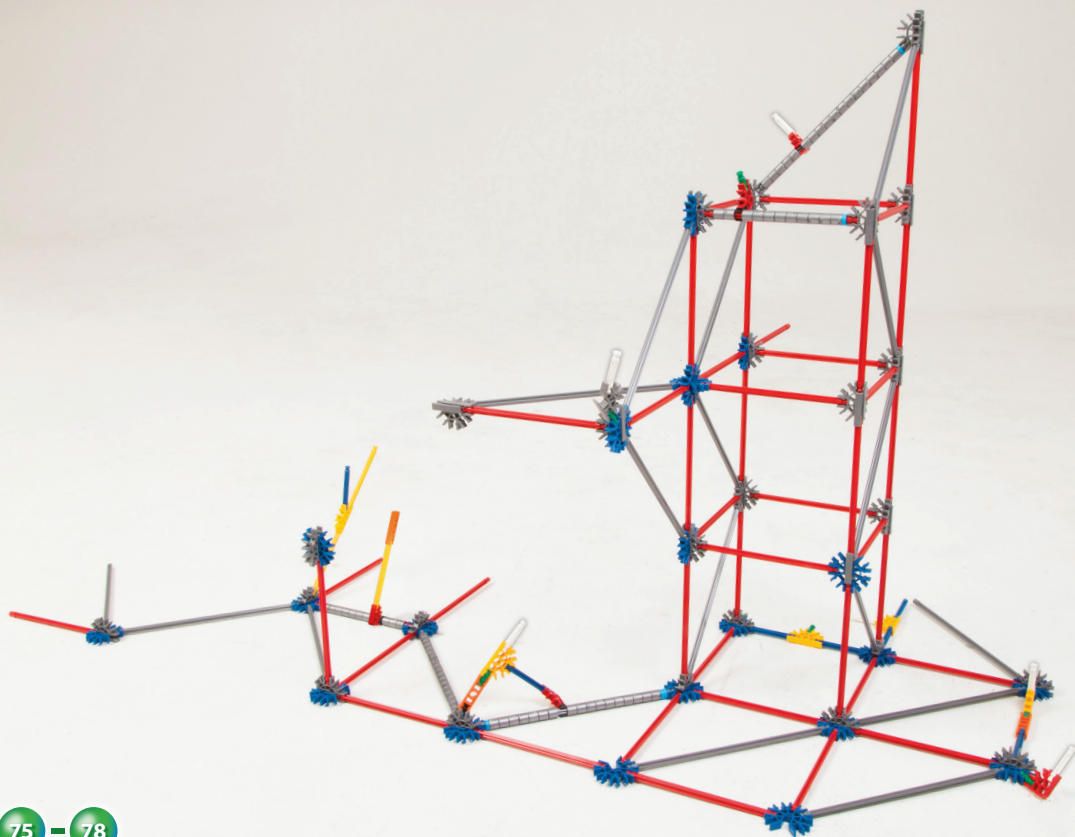





x9

79

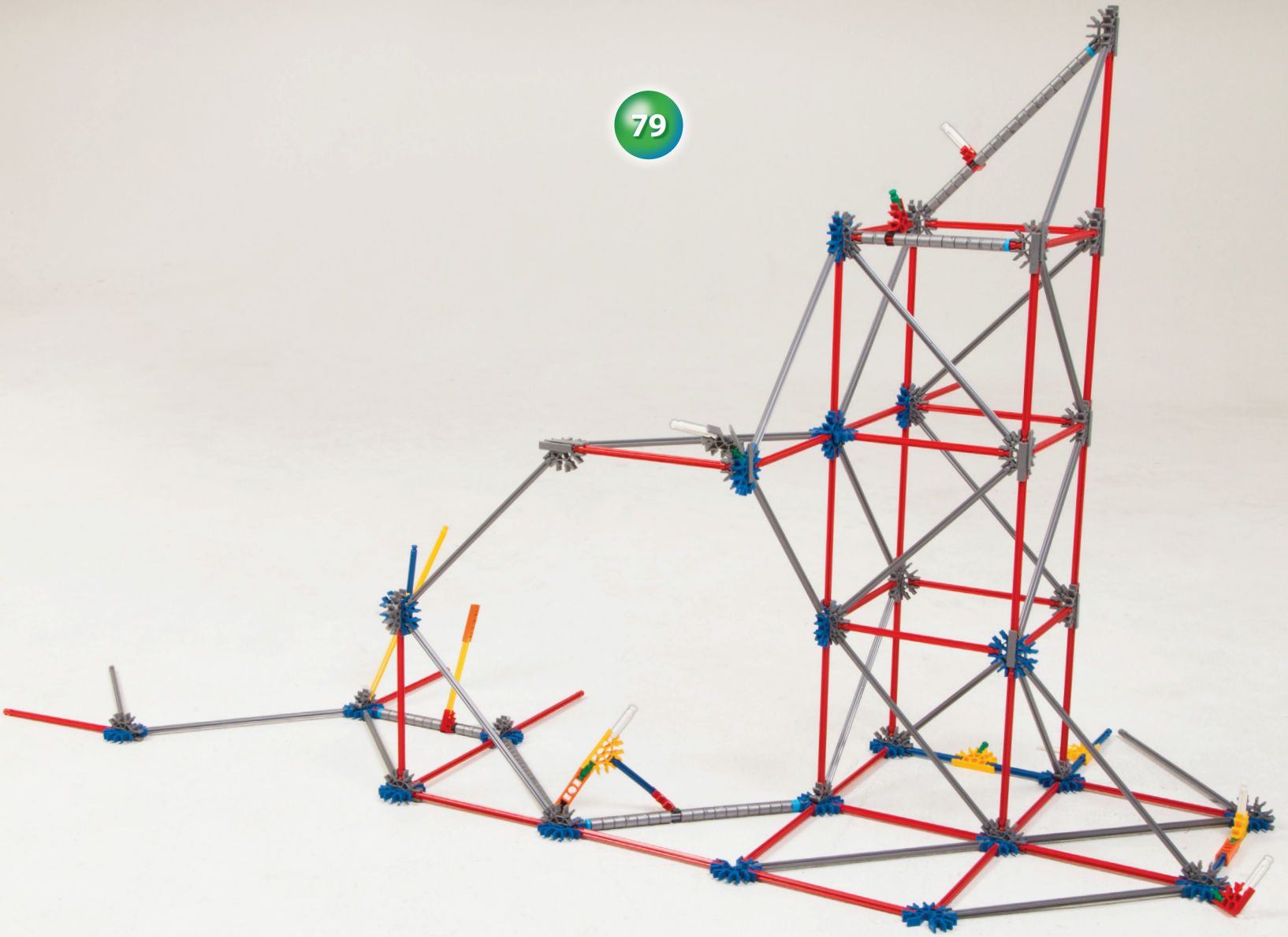

75 - 79

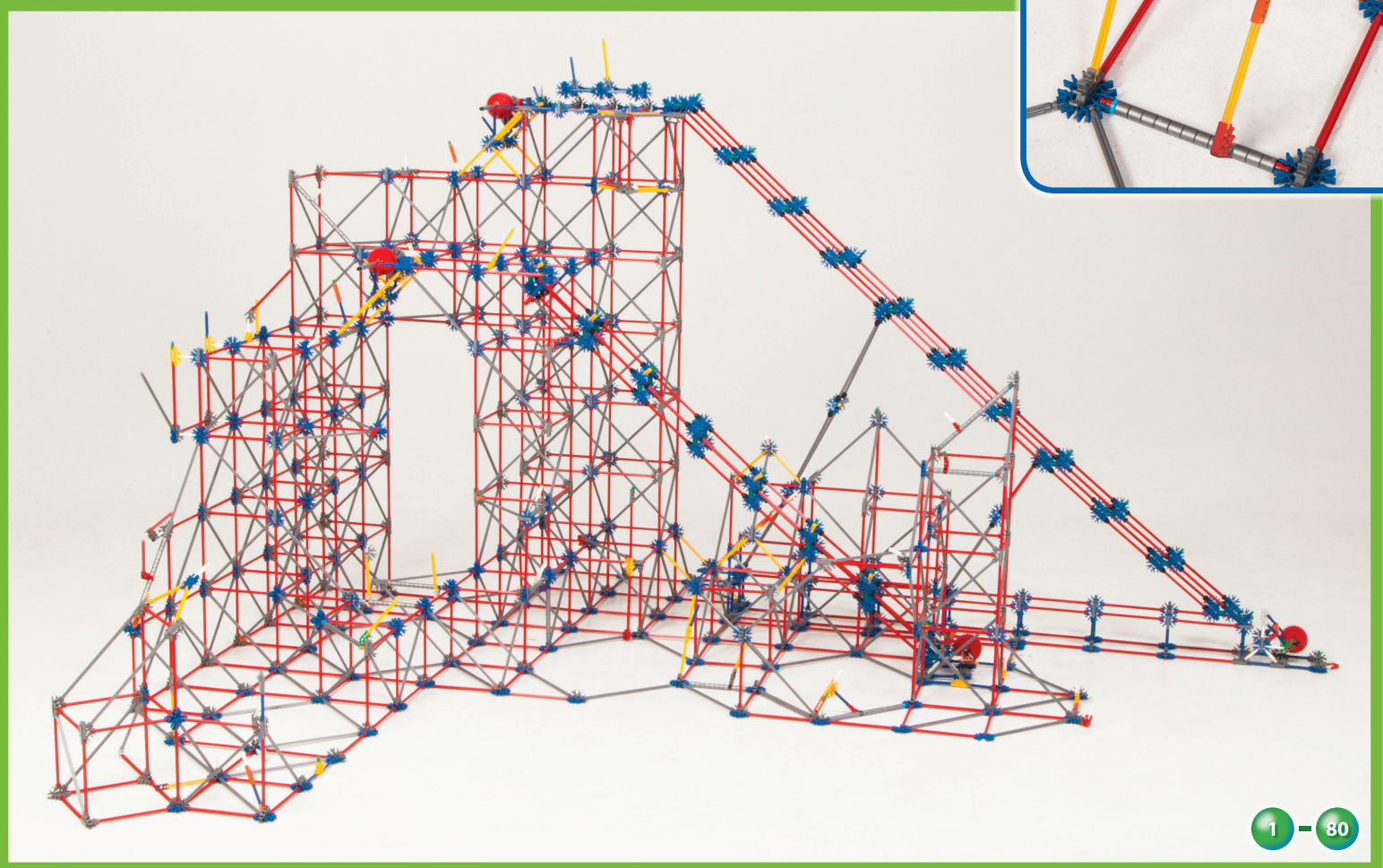
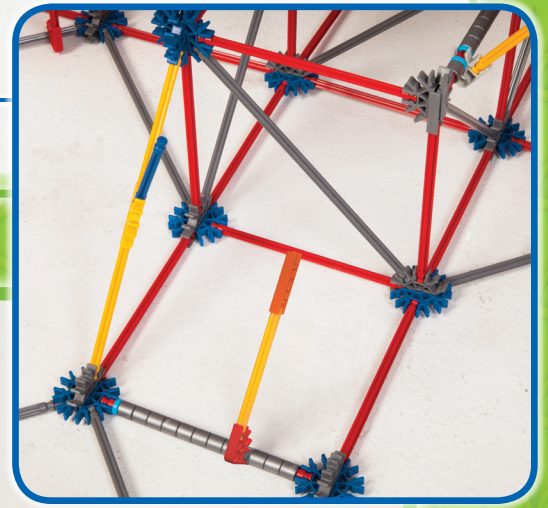
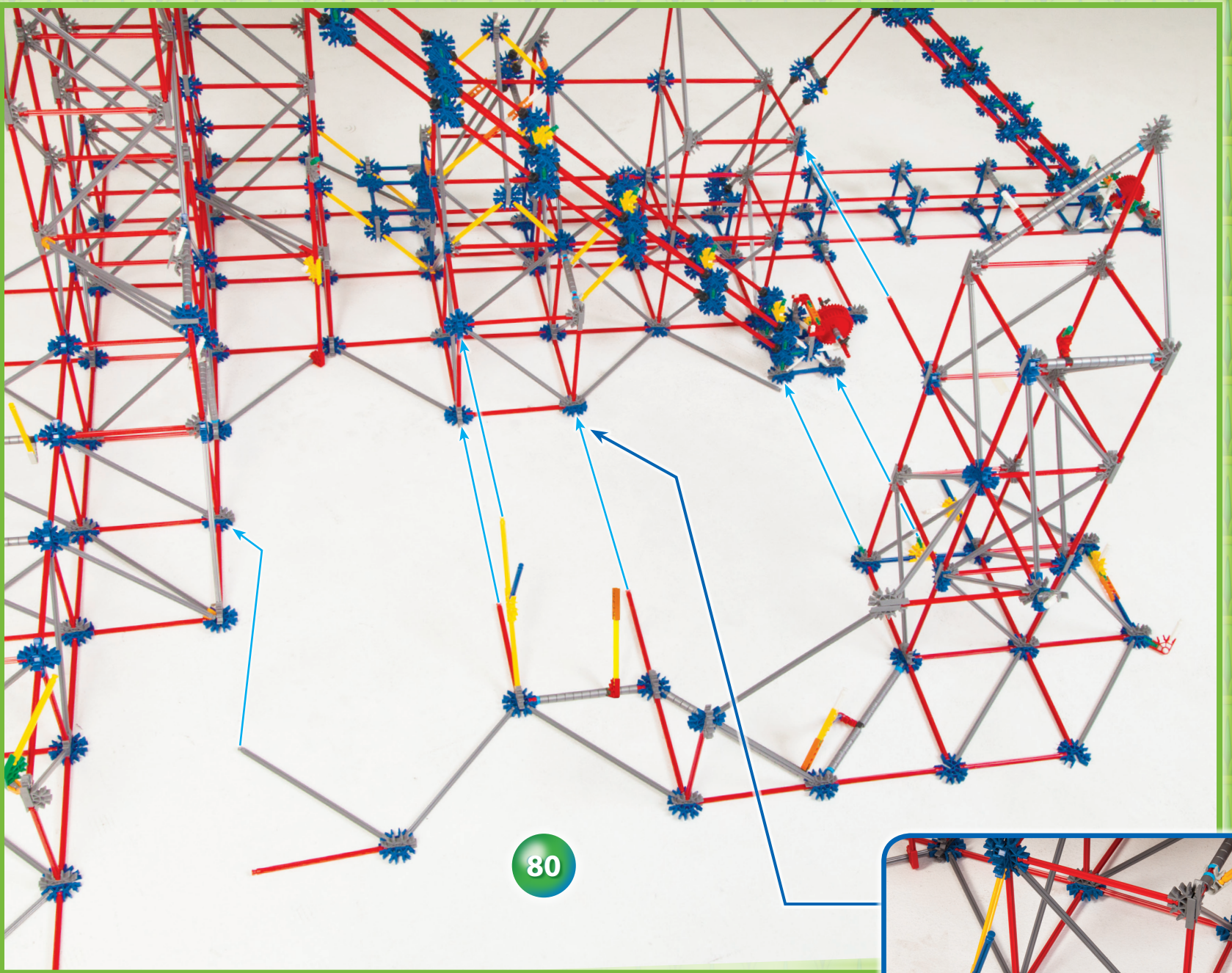

81

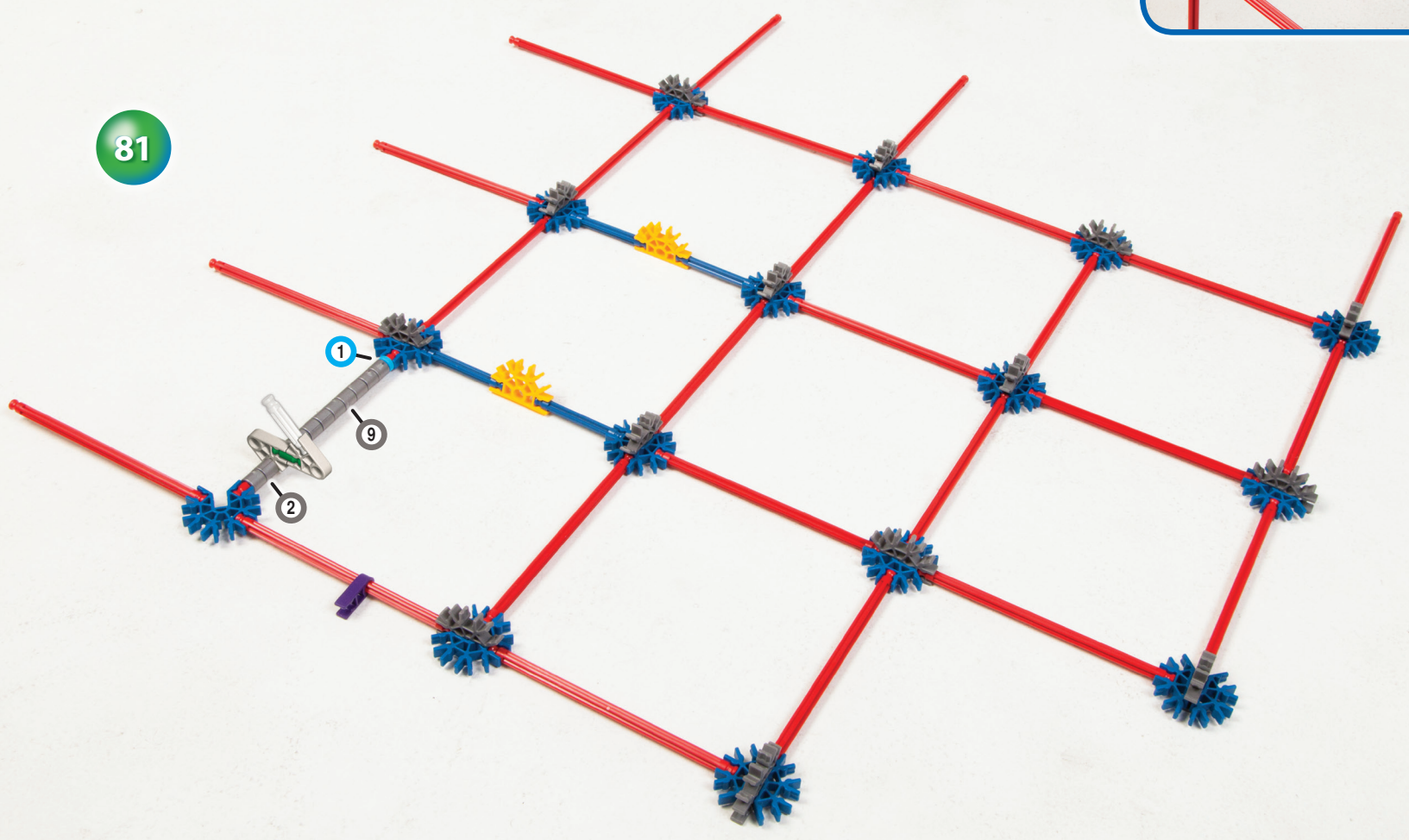

82

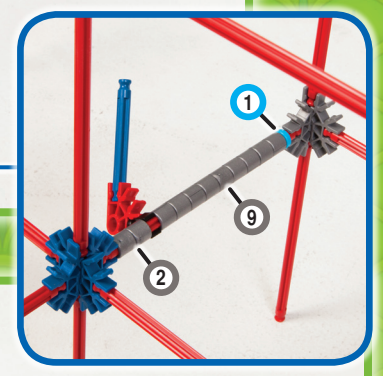
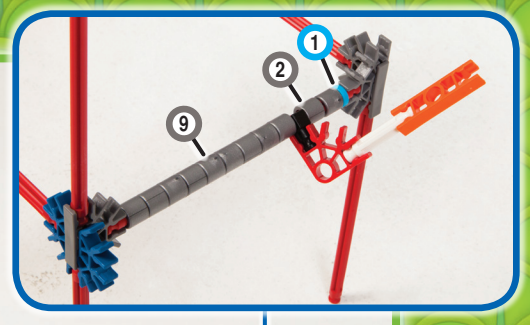
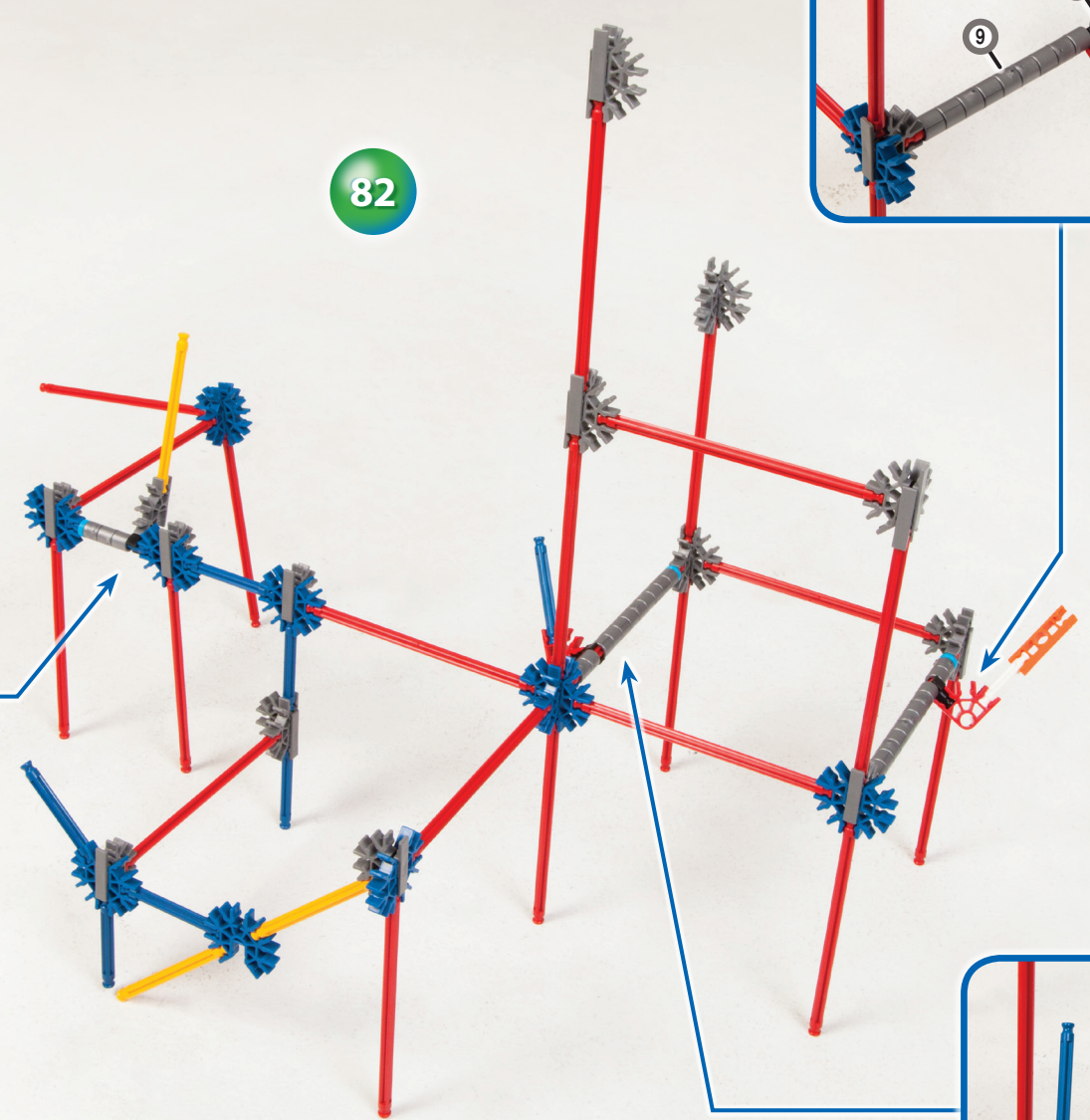
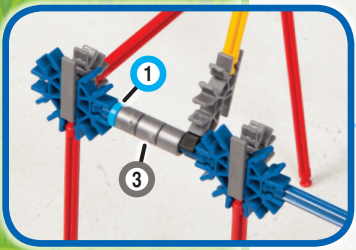

83

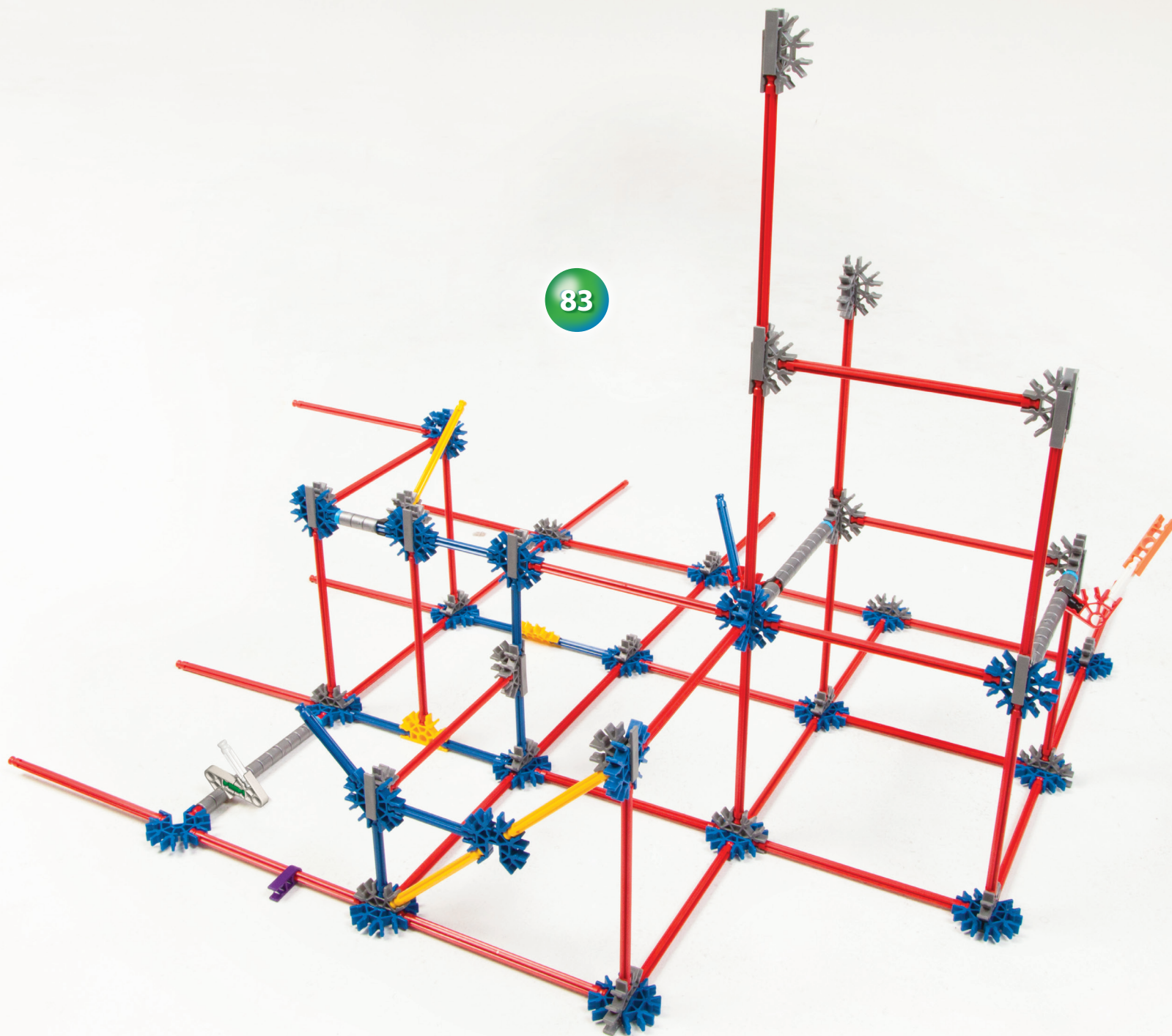

84

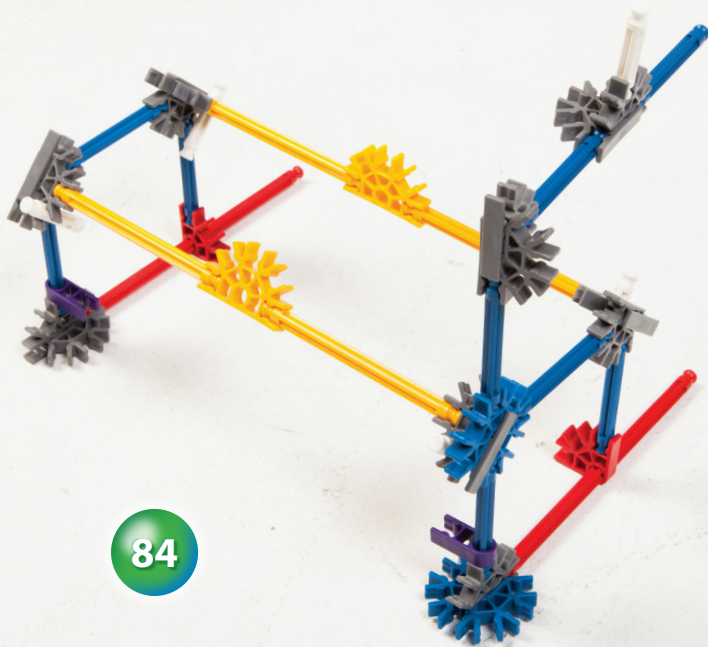

85

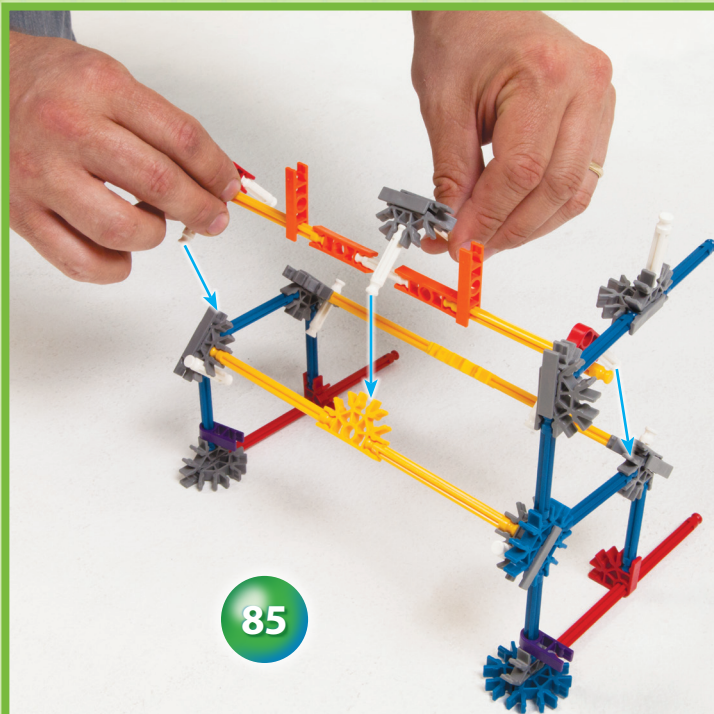

86

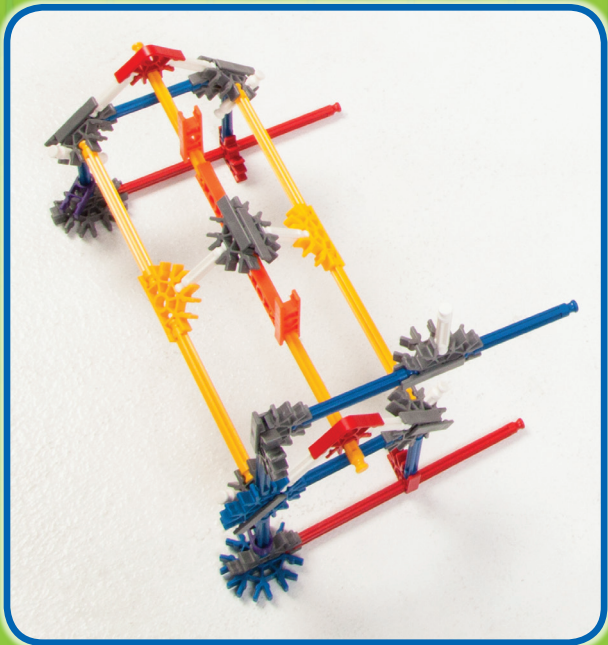
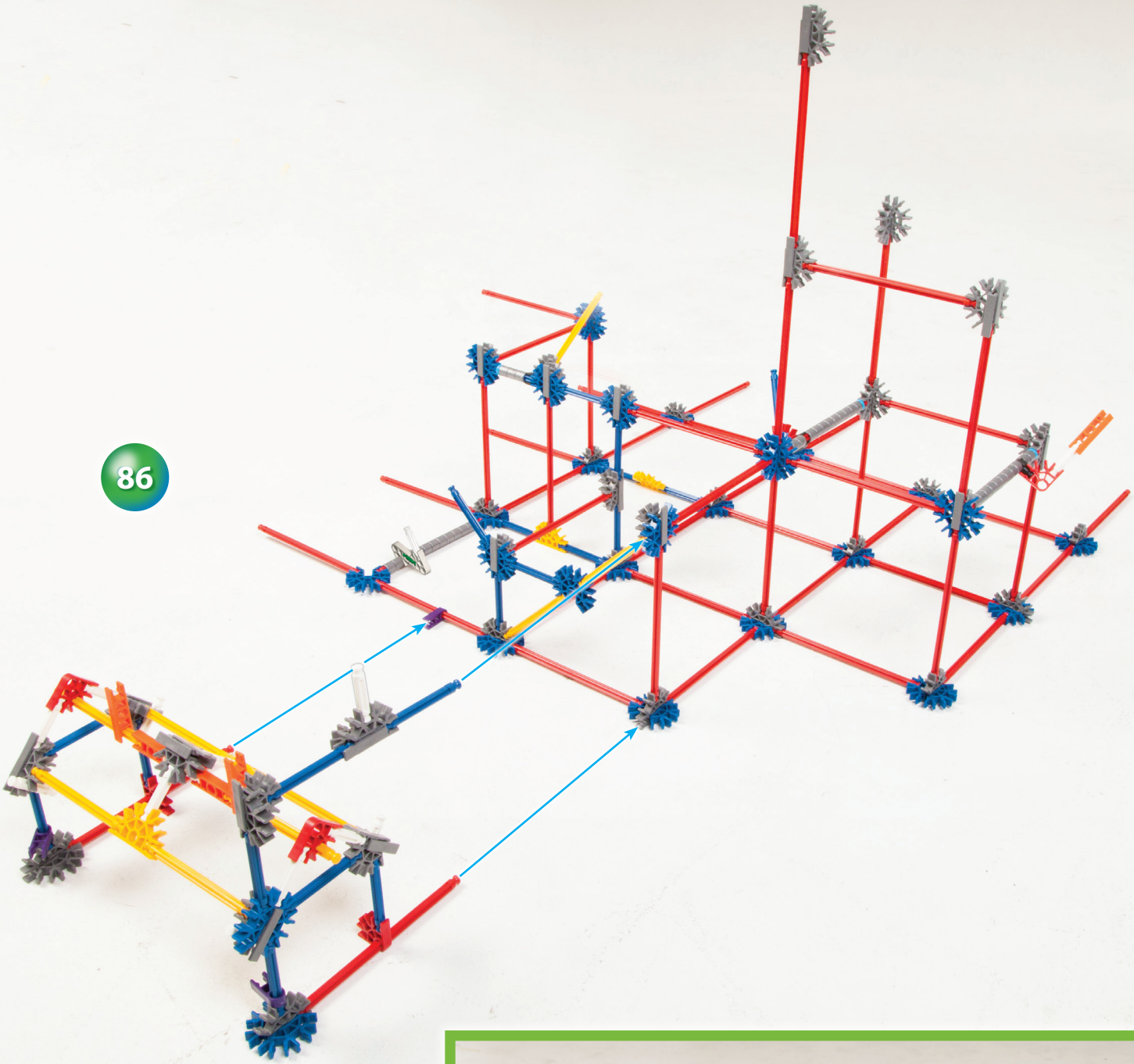

81 - 86

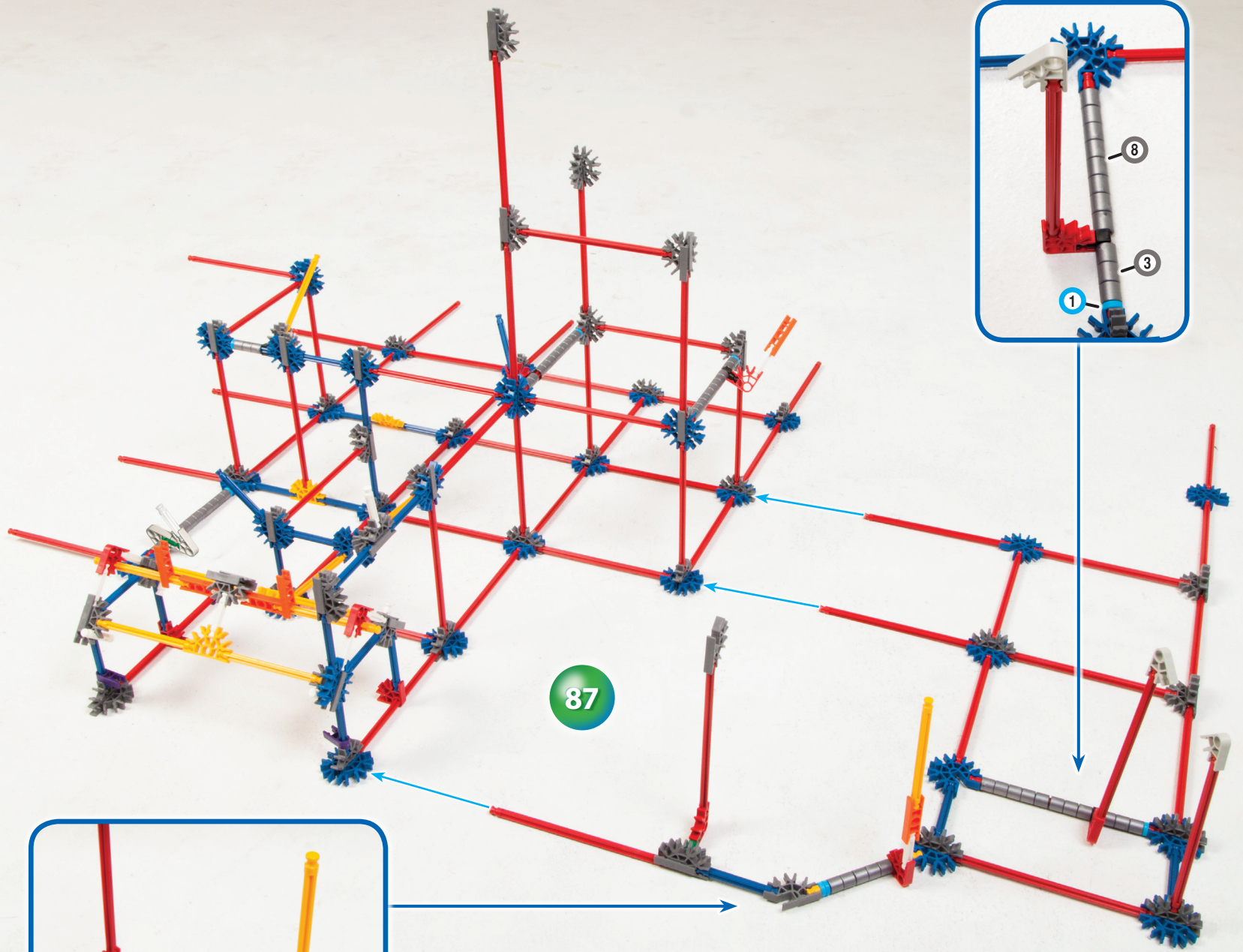

81 — 87



x18

88

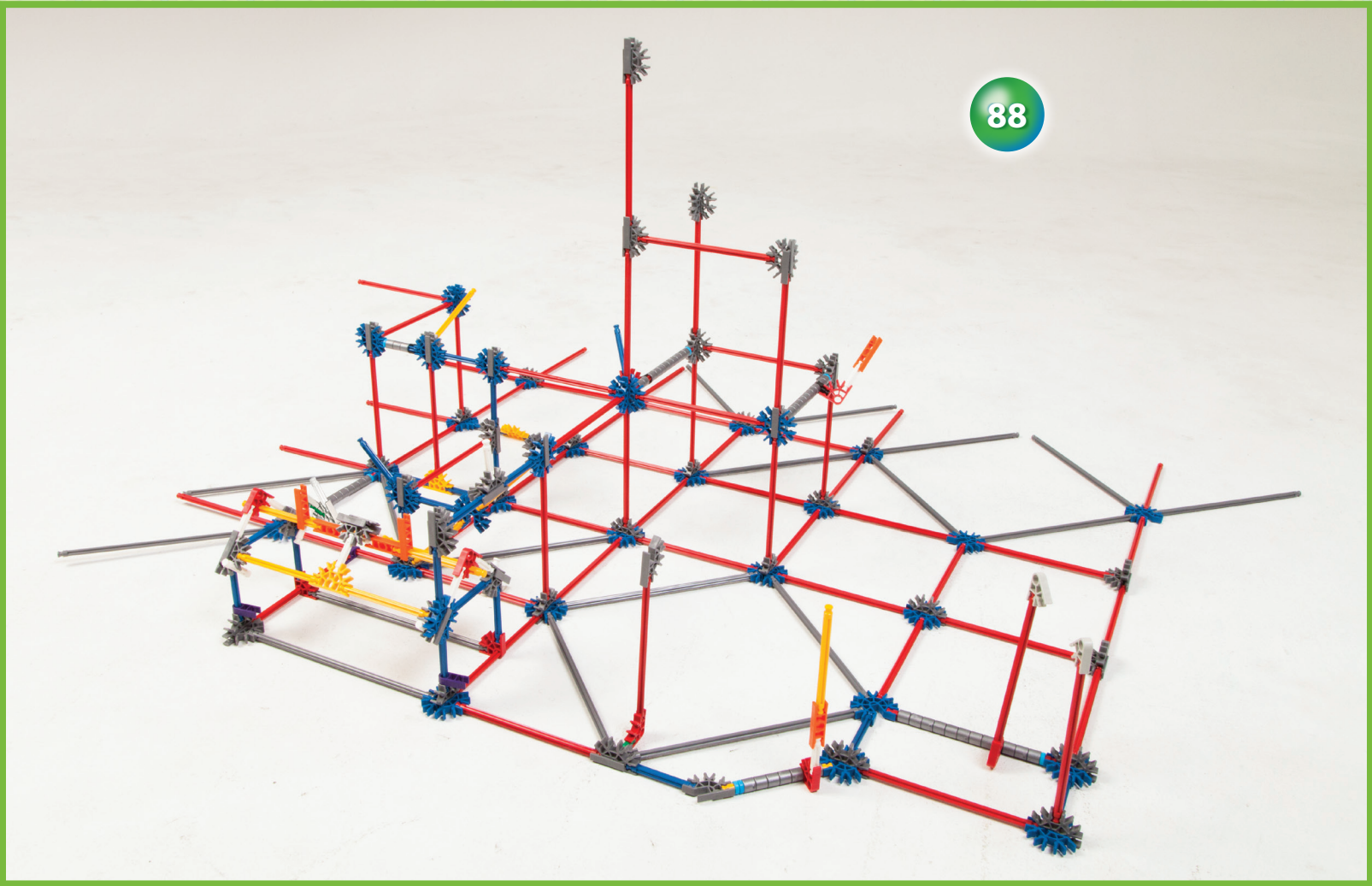

x8

89

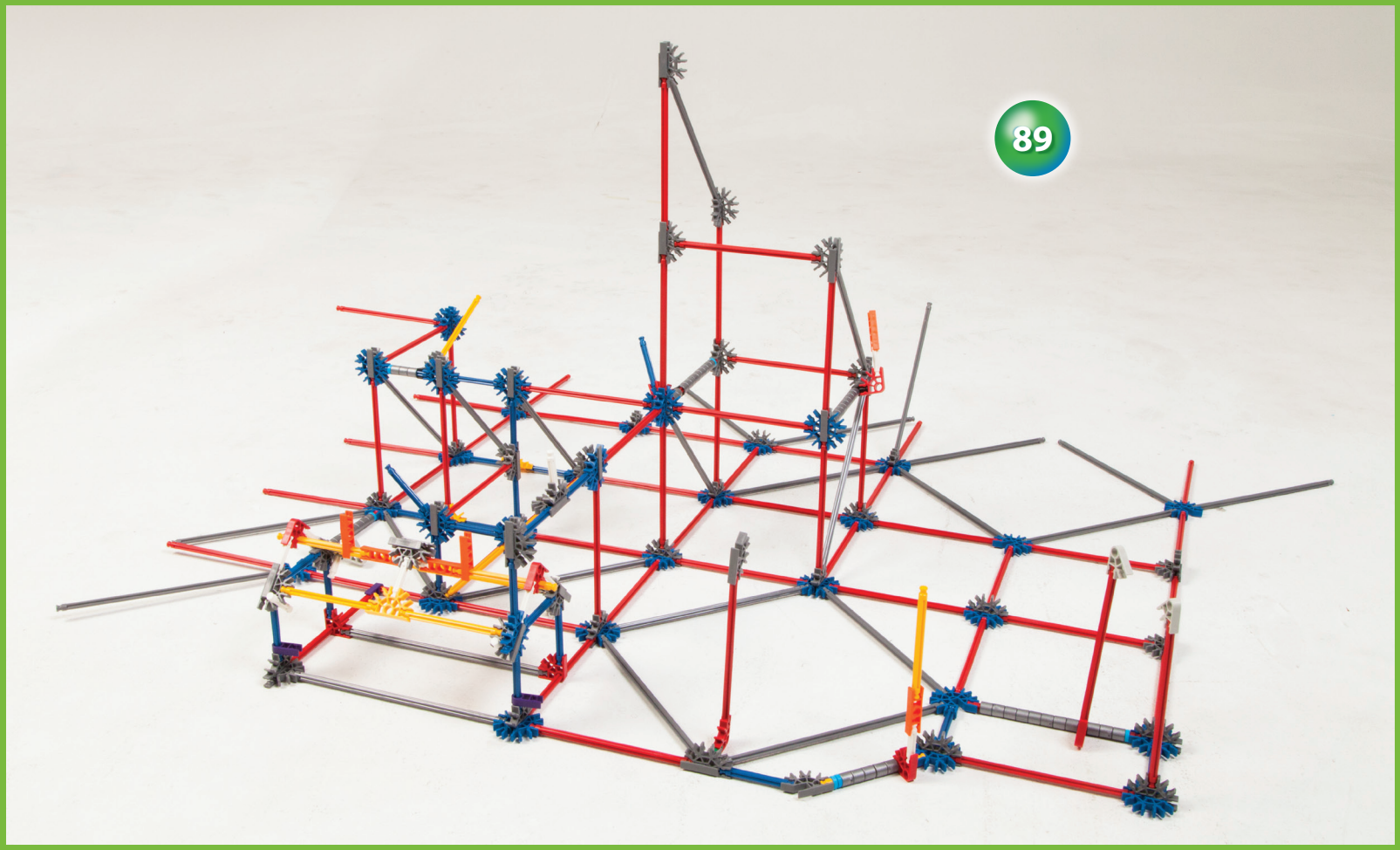

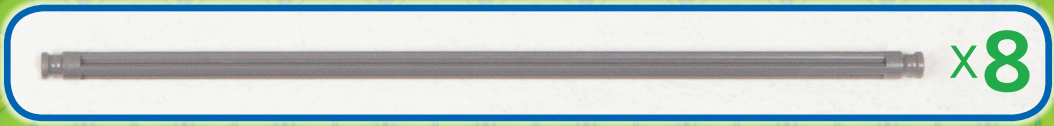

90

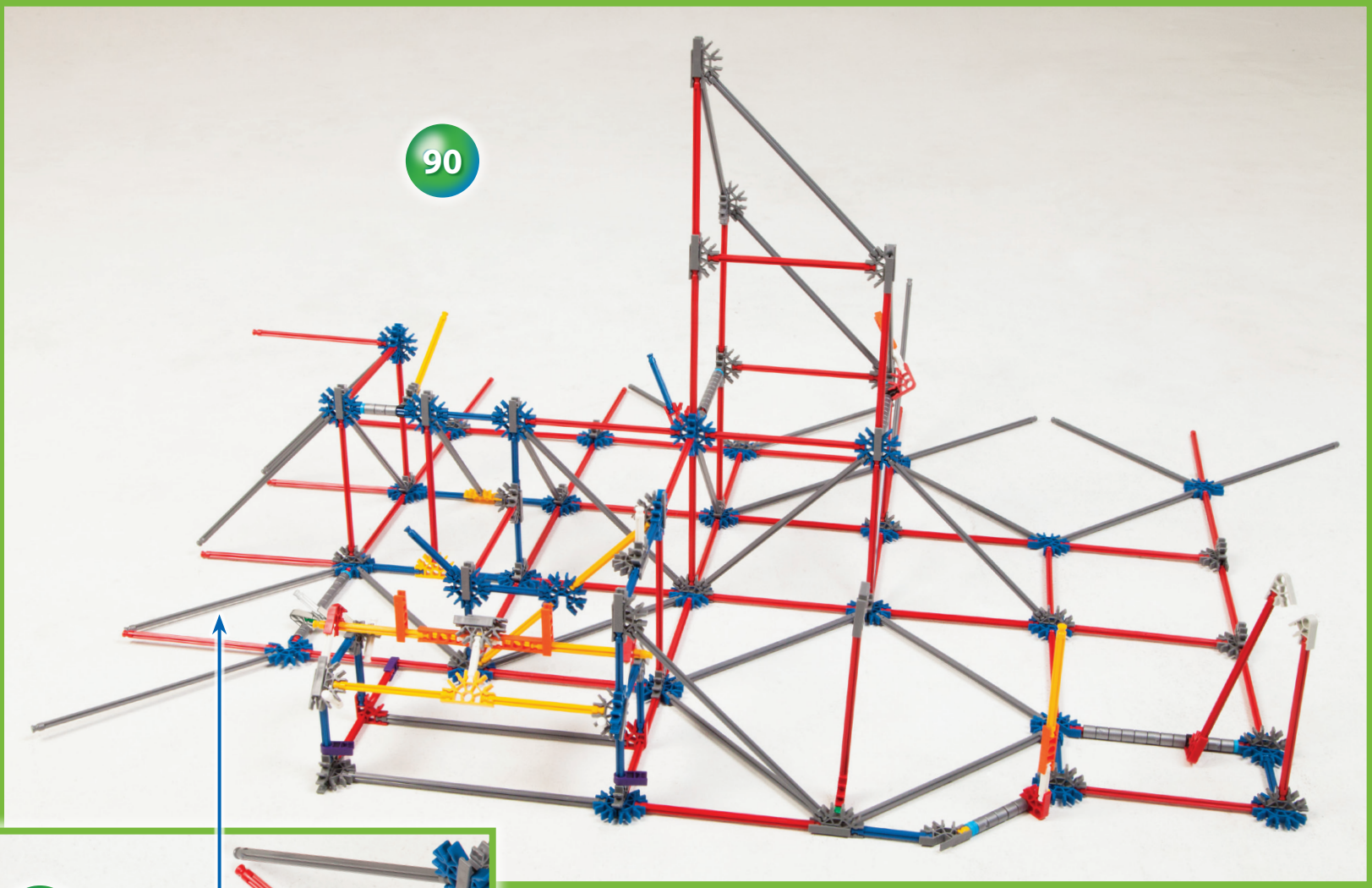

91

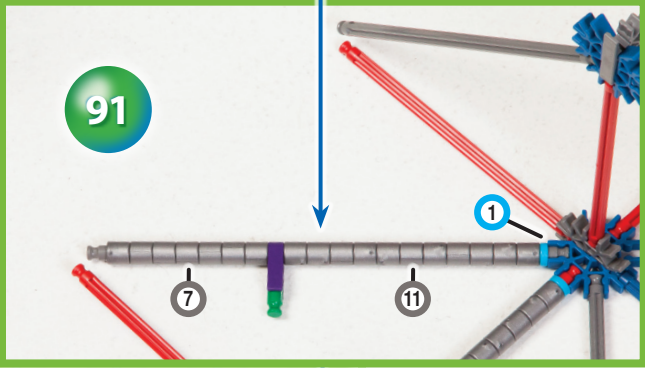

Before you connect these 2 sections of the frame, you will need to add these parts to the gray rod, as shown.

Avant de connecter ces 2 sections du châssis, vous devez ajouter ces tiges grises, comme illustré.

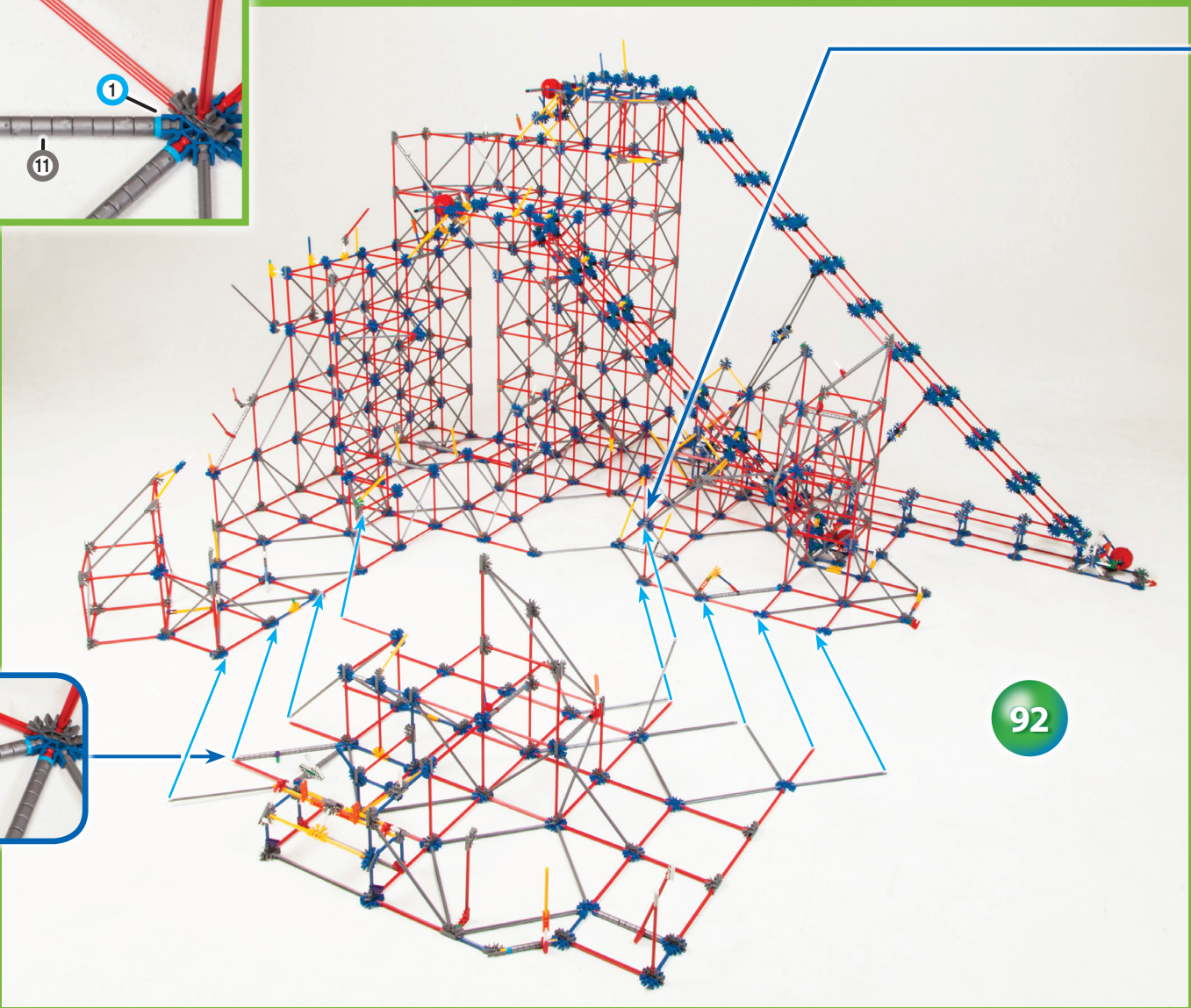
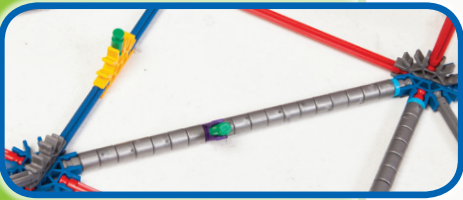

92



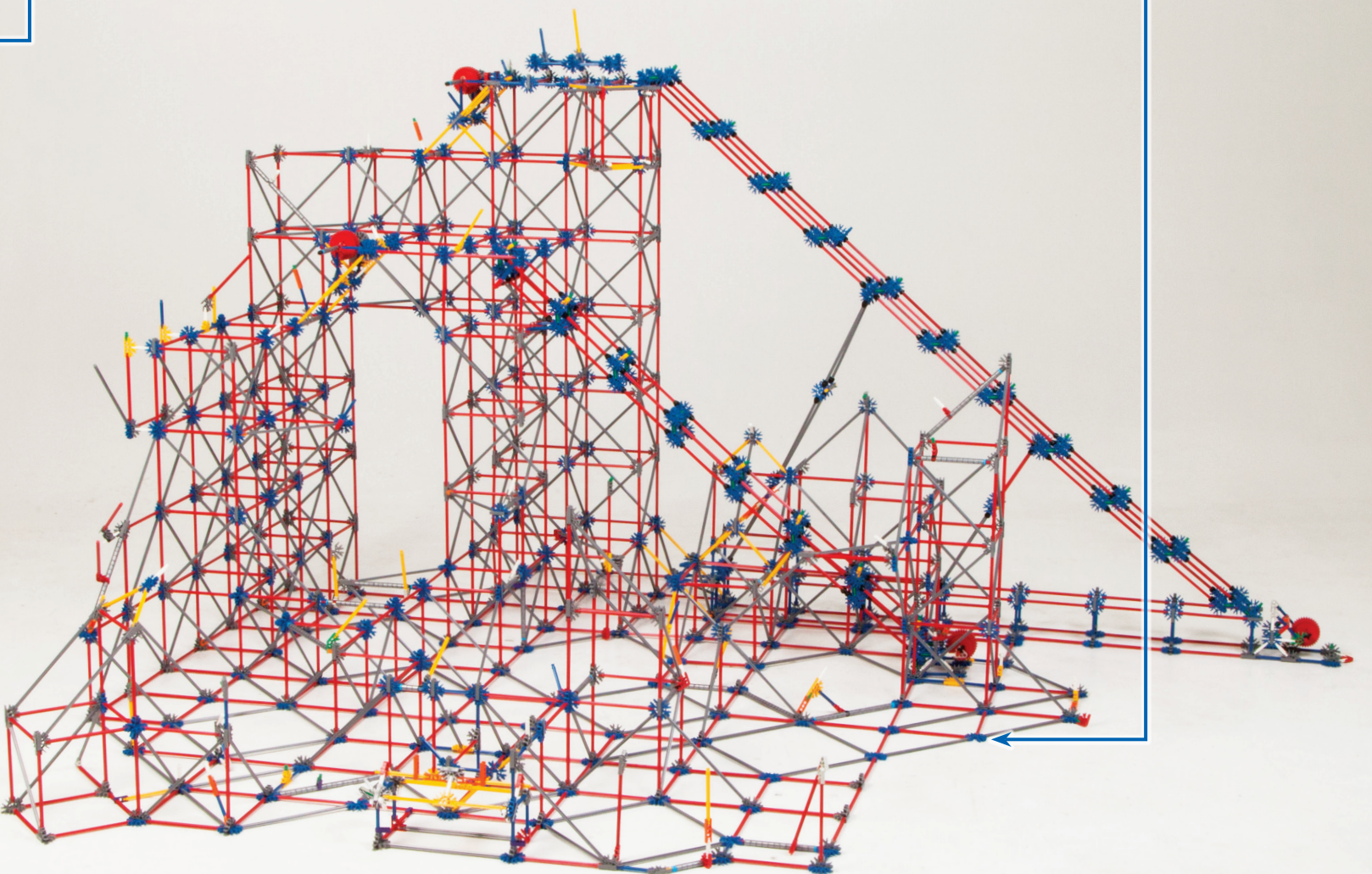
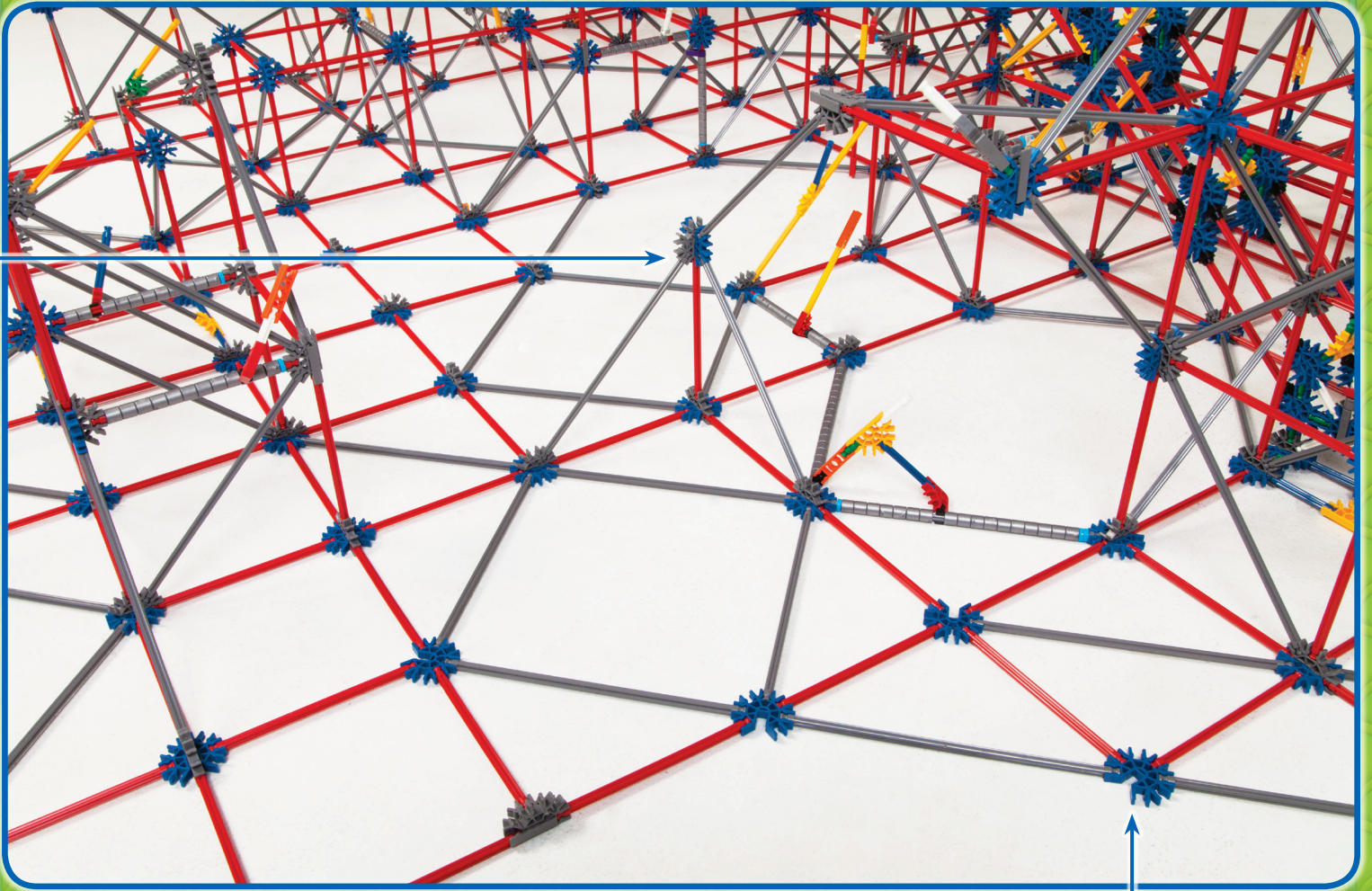

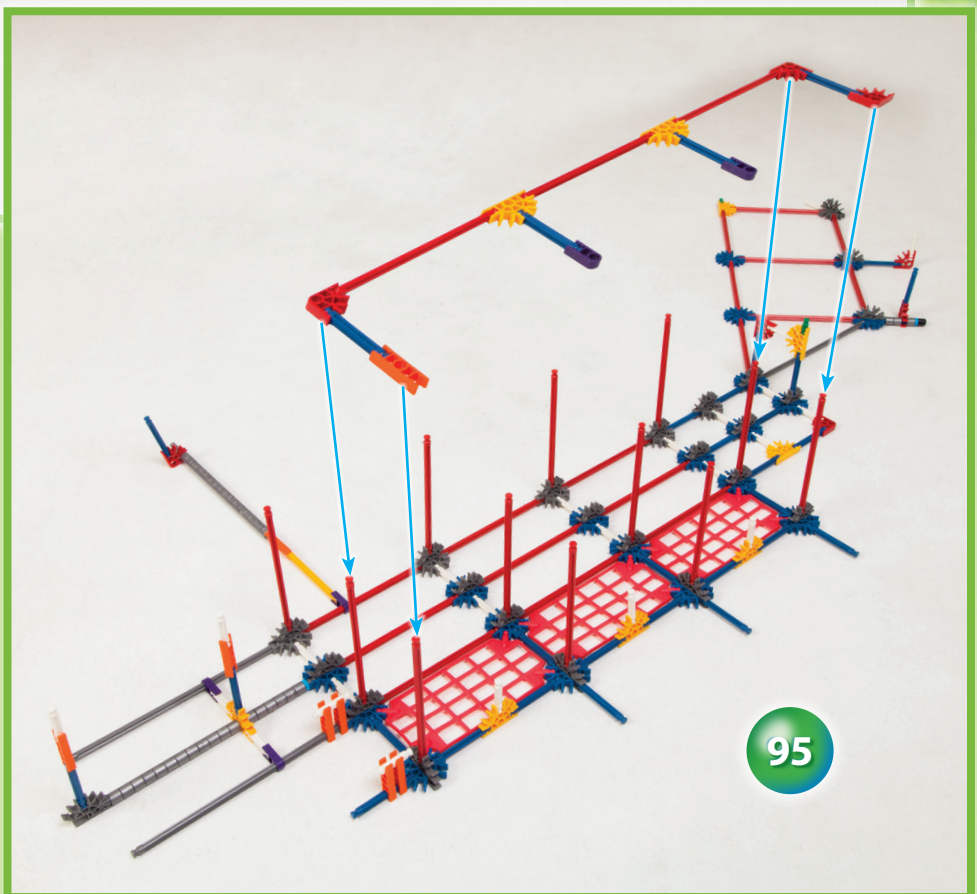
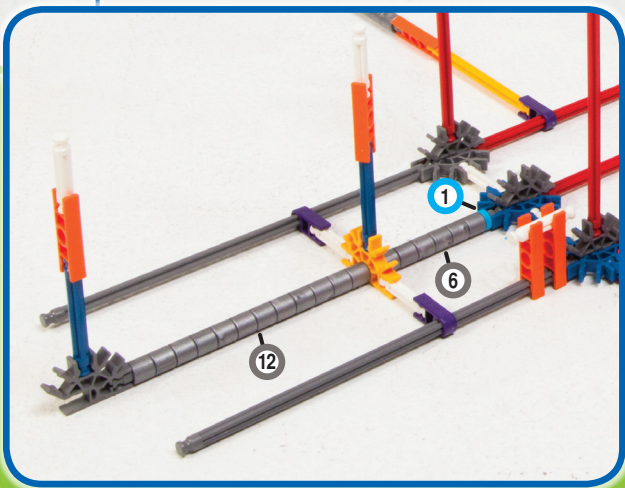
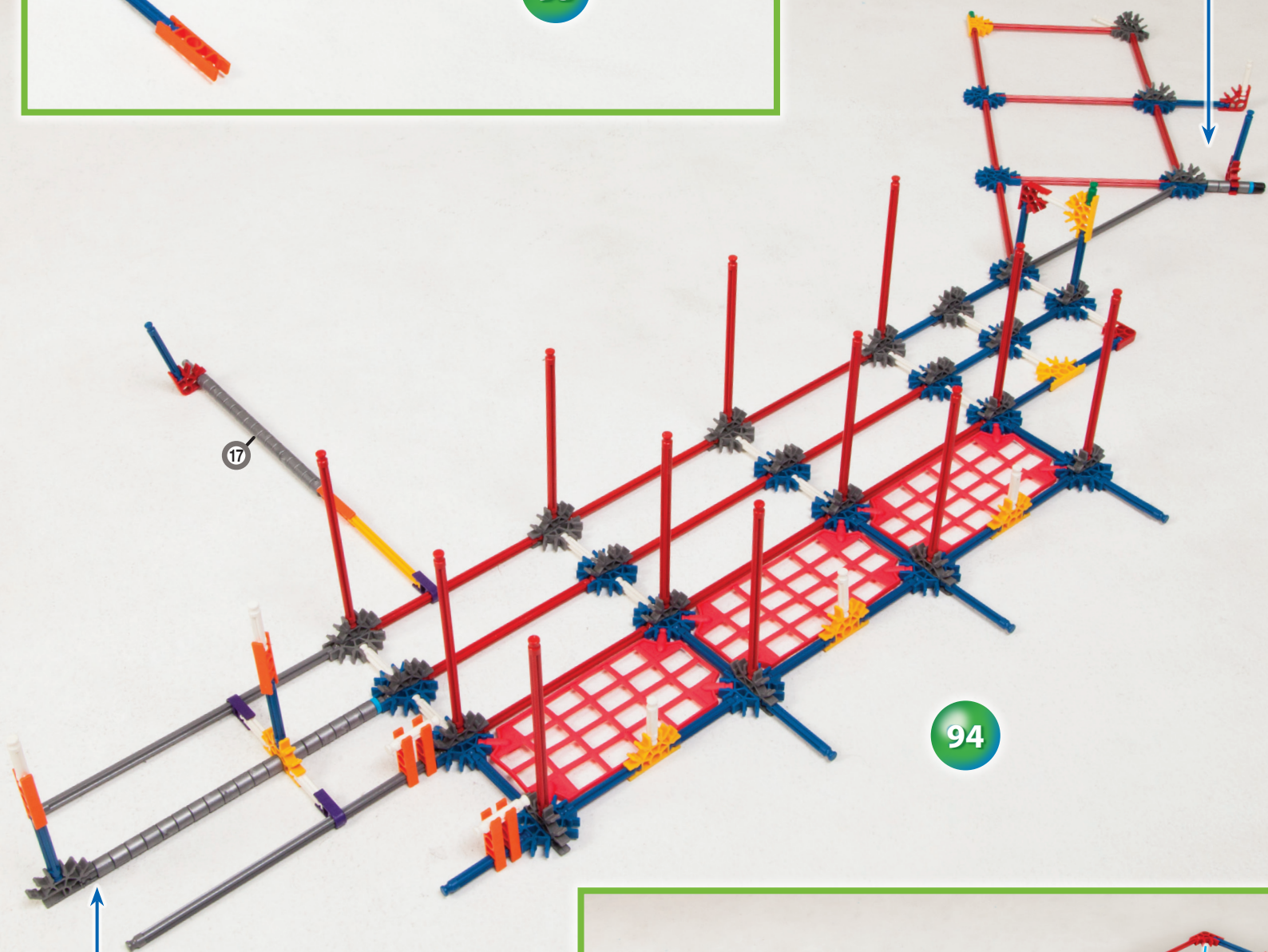
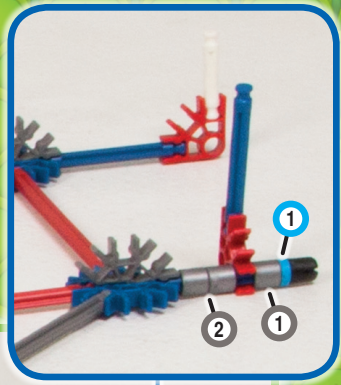

96

